

QEST

DEVOTED ENTIRELY TO

AMATEUR RADIO

Published by the American Radio Relay League

**In this Issue—
Dr. Pickard's Experiments
in
Horizontal
Reception**

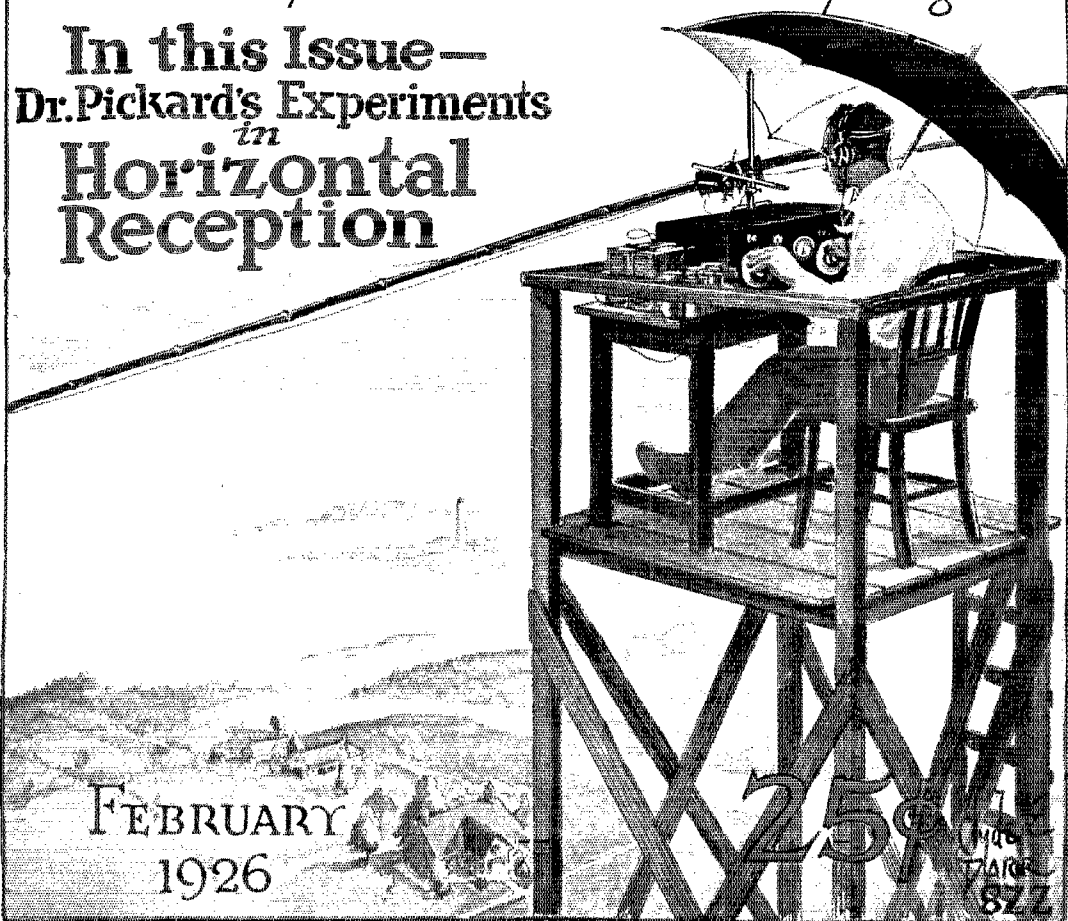

FEBRUARY
1926

25¢

7
JAN
1926
877

Cunningham

RADIO TUBES

*Since 1915—
Standard for all Sets*

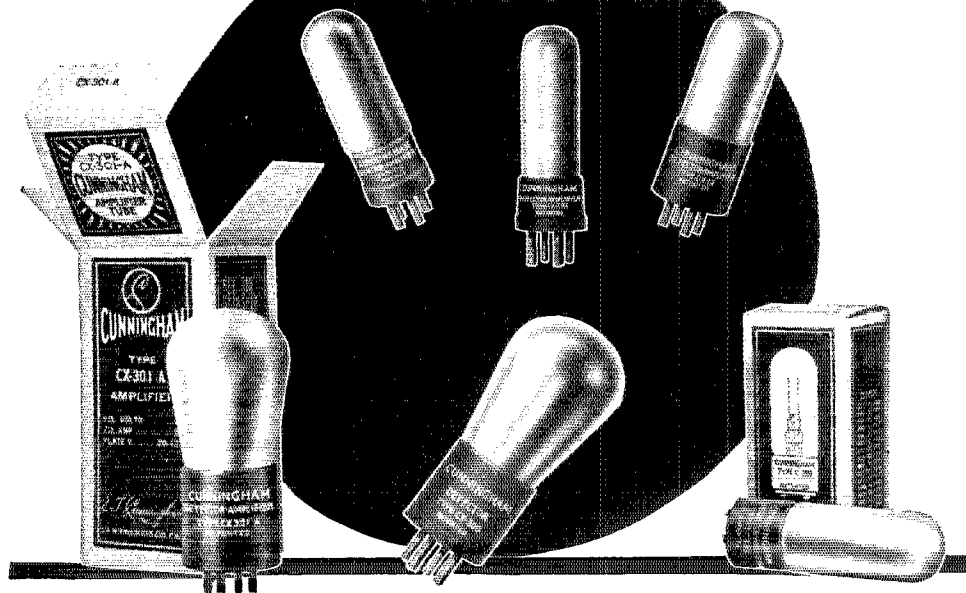

PROVEN DEPENDABLE

In millions of homes where Radio is Entertainment; in thousands of homes where Radio is a Hobby, and in thousands of laboratories where Radio is a serious matter for Research—Cunningham Radio Tubes have proven dependable.

The familiar Orange and Blue Carton is famous the world over as a representative of tube quality inreception plus rugged endurance.

Since 1915--Standard for All Sets

Types C- & CX—

A. J. Cunningham Inc.

NEW YORK

CHICAGO

SAN FRANCISCO

Straight-Line-Frequency Tuning Without the Brakes!

ALL-AMERICAN Condensers, with their smooth-sliding plates (see sketch at left), require no tensioning. There is no sensation of raising a weight or letting it fall.

Compactness, also, far exceeds that of rotor types. (See dimensions on sketch.)

Efficient shielding prevents the touch of the fingers from affecting the tuning, and protects the plates permanently from dust or damage. Taking full advantage of the 360° rotation, there is an ALL-AMERICAN Dial with two scales, both on the upper half, where they are always visible. Used with the ALL-AMERICAN Toroid Coils, these Condensers space out equidistant on the dial all wave-frequency channels from 550 meters down even to 175 meters. Power and selectivity are greatly improved through the absence of stray magnetism.

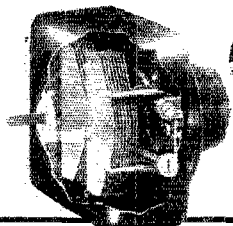
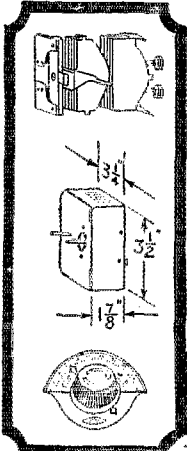
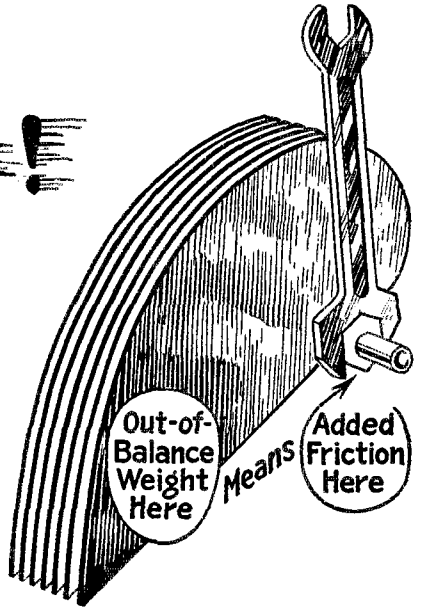

ALL-AMERICAN
STRAIGHT-LINE-FREQUENCY
TUNING

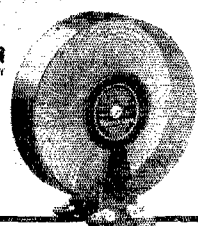

**ALL-AMERICAN
Straight-Line-Frequency
CONDENSERS**

Type C-35 Max. 350 micro-microfarads (Min. 10.5 mmf. at 400 meters) . . . \$4.50

Type C-50 Max. 500 micro-microfarads (Min. 11.8 mmf. at 400 meters) . . . \$3.00

Type C-40, 360° Dial . . . 1.00

**ALL-AMERICAN
TOROID COILS**

Type T-1 Antenna Coupler, \$3.50

Type T-2 R.F. Transformer, 3.50

Set of 3 coils complete, . . . 10.50

The R. F. Transformer has a small primary, closely coupled to the secondary, entirely air-insulated. The coupler has taps for long and short antenna. All bases are of bakelite.

ALL-AMERICAN RADIO CORPORATION, E. N. Rauland, Pres., 4205 Belmont Ave., Chicago, U.S.A.

ALL-AMERICAN
Pioneers in the Radio Industry

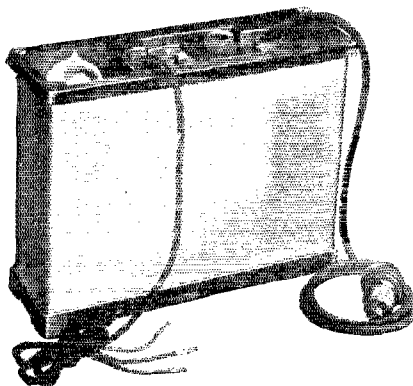

The complete assembled Acme B-Eliminator Type E-1 with tube is shown at left. This unit gives you amplifier voltages and a variable detector voltage from 0 to 70 volts. The amplifier voltages are from 100 to 150. On ten tube sets drawing 50 milliamperes, 100 volts are available and even then no hum or distortion is noticeable. For those having 110 volt D. C. power supply the type E-2 will serve the same purposes, except that high voltages are not possible.

Assembled price:

- Type E-1: 110 Volt, 60 cycle\$50.00 each.
- Type E-2: 110 Volt, D.C. 20.00 each.
- B-4 Transformer (full wave) 7.00 each.
- B-2 30 Henry Choke 5.00 each.

You fellows can make it yourselves!

YOU fellows that know radio can make an Acme B-eliminator that sells for \$50 in the stores very quickly and easily at home—and save the difference.

It's a big step forward for your receiving set. For with the Acme B-eliminator you get better quality, more distance, more volume, no hum and permanent operation. The Raytheon tube used has no filament to burn out.

You get voltages up to 150 volts which conquer any chance of overloading. You get low resistance—that keeps your set pepped up. You get permanent "B" supply. The current cost is nothing—a cent for six hours' steady running.

Send for Information

We have prepared full sized drawings, showing the complete layout,

wiring diagram, drilling dimensions, list of parts, etc. Send twenty-five cents to cover cost. We shall also be glad to send you free with this order a copy of the famous book, "Amplification without Distortion" over 220,000 of which have been sold at ten cents each, and a copy of our Bulletin T on Acme Transmitting Apparatus.

Claude Hains

President Acme Apparatus Co.

Send for your copy!

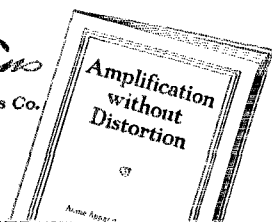

ACME APPARATUS COMPANY
Dept. E 13, Cambridge, Mass.

Gentlemen:

Enclosed find twenty-five cents (stamps) (coin) for complete set of drawings, diagram, and instructions on how to build an Acme B-eliminator.

Also send me without charge "Amplification without Distortion" and Bulletin T on Transmitting Apparatus.

Name.....

Street.....

City..... State.....

Station Call.....

ACME

~for amplification

THE TRAFFIC DEPARTMENT, A. R. R. L.

Manager
A.D.M. D. of C.
A.D.M. Maryland
A.D.M. So. N. J.
A.D.M. West. N. Y.
A.D.M. East. Pa.
A.D.M. West. Pa.
A.D.M. Delaware

3DW
3AB
3HG
3EH
3PA
3FM
3ZD
3AIS

Manager
A.D.M. Michigan
A.D.M. Ohio
A.D.M. Illinois
A.D.M. Wisconsin
A.D.M. Indiana
A.D.M. Kentucky

8ZZ
8ZZ
8AA
9AAW
9VD
9CTQ
9BT

Manager
A.D.M. Minnesota
A.D.M. So. Dak.
A.D.M. No. Dak.

9ZT-9XAX
9RGU
9CJS
9CSI

Manager
A.D.M. Mississippi
A.D.M. Arkansas
A.D.M. Tennessee
A.D.M. Louisiana

4MM
5AKP
5XAB
4KN
5UK

Manager
A.D.M. No. N. J.
A.D.M. N. Y. C.
A.D.M. East. N. Y.

2BRB
2WR
2CWR
2PV

Manager
Asst. Secy. to DAF
A.D.M. Iowa
A.D.M. Mo.
A.D.M. Kansas
A.D.M. Nebraska

9DXY
9ARZ
9RR
9CWS
9CJT

Manager
A.D.M. R. I.
A.D.M. N. H.
A.D.M. Vt.
A.D.M. W. Mass.
A.D.M. E. Mass.
A.D.M. Conn.
A.D.M. Maine

1AWVY
1BVB
1GL
1AJG
1ASU
1KY
1BM

Manager
A.D.M. Montana
A.D.M. Wash.
A.D.M. Oregon
A.D.M. Idaho
A.D.M. Alaska

7EK ex 7ABB
7NT
7PT
7FT-XAF
7OB
7DE

Mgr. Southern Section
A.D.M. Dist. 1, 2, 3
A.D.M. Ariz.
Mgr. Northern Section
A.D.M. Dist. 4
A.D.M. Dist. 5
A.D.M. Dist. 6
A.D.M. Nevada
Mgr. Hawaiian Section
A.D.M. Hawaii

8RTR
8TO
8ANO
8ZX
8NX
8AWT
8TO
8TO
8BCG

Manager
A.D.M. West Va.
A.D.M. Virginia
A.D.M. No. Carolina

8RZ
8BSU-AKZ
8CA
4JR

Manager
A.D.M. Colo.
A.D.M. Utah

7ZO
9GAA
8ZT

Manager A.D.M. Ala.
A.D.M. S. C.
A.D.M. Fla.
A.D.M. Ga.
A.D.M. Porto Rico

5ATP
4RE
4FM
4TO
4OI

Manager
A.D.M. Oklahoma
A.D.M. So. Texas
A.D.M. No. Texas

5ZC
5APG
5YK
5AJT

Manager
A.D.M. P. E. I.
A.D.M. N. B.

1DD
1BZ
1BT

Manager
A.D.M. Can. Ont.
A.D.M. East. Ont.
A.D.M. So. Ont.

9BJ
5VH
8AFP
8TI

Manager
A.D.M. Sask.
A.D.M. Manitoba

2CG
5CG

Manager
A.D.M. Sask.
A.D.M. Manitoba

4AO
4CR-9BX
4DE

ATLANTIC DIVISION

E. B. Duval
A. B. Goodall
G. L. Deichmann, Jr.
H. W. Densham
C. S. Taylor
J. F. Hau
P. E. Wiggin
H. E. Layton

Box 317
1824 Ingleide Ter.
Chapel Gate Lane
140 Washington St.
598 Masten St.
2085 E. Kingston St.
714 Johnston St.
305 Washington St.

Edmonston, Md.
Washington
Ten Hills, Baltimore
Collinswood
Buffalo
Philadelphia
Wilkinsburg
Wilmington

CENTRAL DIVISION

C. E. Darr
C. E. Darr
C. E. Nichols
W. E. Schweitzer
C. N. Crapo
D. J. Angus
J. C. Anderson

187 Hill Ave., Highland Pk.
187 Hill Ave., Highland Pk.
739 Weacock Ave.
4264 Hazel Ave.
443 Newton Ave.
510 N. Illinois St.
Gensary Farm

Detroit, Mich.
Detroit
Lima
Chicago, Ill.
Milwaukee
Indiana polis
Lexington

DAKOTA DIVISION

D. C. Wallace
C. L. Barker
M. J. Junkins
M. L. Monson

54 N. Penn Ave.
E. 12th St.

Minneapolis, Minn.
Hennepin
Bryant
Grafton

DELTA DIVISION

B. F. Painter
J. W. Gullett
Dr. L. M. Hunter
L. K. Rush
C. A. Freitag

424 Hamilton Nat. Bank Bldg.
818-29th Ave.
207 1/2 Main St.
4 Second St.
3520 Dorsey St.

Chattanooga, Tenn.
Meridian
Little Rock
Bemis
New Orleans

HUDSON DIVISION

E. M. Glaser
A. G. Wester, Jr.
P. H. Mardon
H. N. Ammetheuser

345 E. 13th St.
1075 Chancellor St.
1309 W. Farms Rd.
178 Quail St.

Brooklyn, N. Y.
Irrington
Bronx
Albany

MIDWEST DIVISION

P. H. Quinby
B. Diehl
D. E. Watts
L. B. Laizure
C. M. Lewis
H. A. Nielsen

Box 134A, Rt. 6
3006 So. Ave.,
116 Hyland Ave.
3020 Mercer St.
312 E. Kuldge St.
4708 N. 30th St.

Omaha, Neb.
Omaha
Ames
Kansas City
Yates Center
Omaha

NEW ENGLAND DIVISION

F. F. Cushing
D. B. Fancher
C. P. Sawyer
Charles T. Kerr
C. V. Green
Miss Gladys Hannah
H. E. Nichols

78 Collins St.
38 Franklin St.
11 Stark St.
6 Airle St.
3 Sumner Rd.
60 Benham Ave.

Springfield, Mass.
Westerly
Manchester
Poultney
Worcester
Cambridge
Bridgeport

NORTHWESTERN DIVISION

Everett Kick
A. R. Willson
Orto Johnson
Ashley C. Dixon, Jr.
K. S. Norquest
Leo H. Machin

3802 Hort Ave.
1340 30th West
1350 East 36th St.
Weather Bureau
Box 452

Everett, Wash.
Remey
Seattle
Portland, Ore.
Boise
Cordova, Alaska

PACIFIC DIVISION

L. E. Smith
E. H. Dursman
D. B. Lamb
P. W. Dann
F. J. Quement
H. Molinari
St. Clair Adams
C. B. Newcomb
K. A. Cantin
W. H. Friedly

304 N. Palmer Ave.,
1200 Tamalind Ave.
229 W. First St.
562-35th St.
51 Pleasant St.
653 Union St.
1593 Pihoki St.
1825 Dole St.

Whittier, Calif.
Hollywood
Mesa
Oakland
San Jose
San Francisco
Eureka
Yorlington
Honolulu, T. H.
Honolulu, T. H.

ROANOKE DIVISION

W. T. Gravelly
C. S. Hoffman, Jr.
J. J. Wohford
R. S. Morris

124 Main St., Box 245
126 Chantal Court
118 Cambridge Ave.
413 S. Broad St.

Danville, Va.
Wheeling
Roanoke
Gastonia

ROCKY MOUNTAIN DIVISION

N. R. Hood
C. R. Stedman
Art Johnson

1022 S. Ash St.
1641 Albion St.
247 E. 7th South St.

Casper, Wyo.
Denver
Salt Lake City

SOUTHEASTERN DIVISION

A. D. Trum
A. Dupre

217 Catoma St.
290 Wofford Campus

Montgomery, Ala.
Spartanburg

E. G. Watts, Jr.
J. Morris
Luis Rexach

1025 SW 9th St.
58 Frederica St.
Box 319

Miami, Fla.
Atlanta
San Juan

WEST GULF DIVISION

E. M. Corlett
K. M. Ehret
R. A. Sahn
W. B. Forrest, Jr.

2515 Catherine St.
2904 N. Robinson St.
Box 569
502 Royal St.

Dallas, Texas
Oklahoma City
New Braunfels
Waxahatche

MARITIME DIVISION

W. C. Borrett
W. Hyndman
T. B. Lacey

14 Sincclair St.
c/o N. B. Power Co.

Dartmouth, N. S.
Charlottetown
St. John

ONTARIO DIVISION

W. Y. Sloan
A. R. Williams
P. A. C. Harrison
J. E. Favne

167 Glosa Ave.
56 Madison Ave.
181 Hopedell Ave.
303 N. Brock St.

Toronto Ont.
Toronto
Ottawa
Sarnia

QUEBEC DIVISION

J. V. Arvalo

193 Decarie Blvd.

Montreal, Que.

VANCOUVER DIVISION

Wm J. Rowan

1928 Pender St., E.

Vancouver, B. C.

WINNIPEG DIVISION

W. R. Pottle
E. L. Maynard
F. E. Rutland, Jr.

1164 Willow Ave.
452 St. John Ave.

Moose Jaw, Sask.
Morse
Winnipeg

Grebe
Binocular Coils
Rec. U.S. Pat. 607,
and
Low-wave
Extension
Circuits

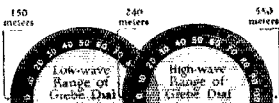
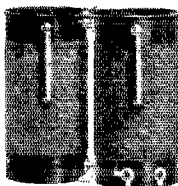

A B
The high-wave reception range of the Grebe dial (B)—from 240 down to 150 meters—equals the practical tuning range of the usual receiver. The low-wave range of the Grebe dial (A) provides additional reception down to 150 meters.

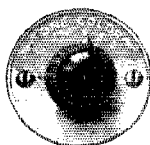

Grebe "Colortone"

Usual
Dial

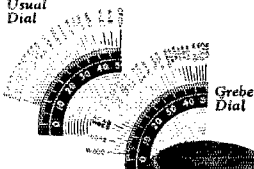

Grebe
S-L-F
Condenser



Flexible Unit Control



"Take the lead and set an example of diligent toil."
—Confucius

Much toil and great diligence have made the Synchronphase worthy of first rank in radio receivers.

Doctor Ma

Imitation

—the Sincerest Flattery

LAST year Grebe developed the fieldless **L** Binocular Coils and **S-L-F** (straight line frequency) Condensers.

These Grebe developments have now been adopted on a number of other receivers.

This year Grebe has devised the **Low-Wave Extension Circuits**, "**Colortone**," and **Flexible Unit Control**. It will be interesting to see how soon these, too, are added to other sets.

In buying a Grebe Synchronphase now, you will have advances in radio construction, such as other receivers will probably show next season.

Ask your dealer to demonstrate all these Grebe developments.

A. H. Grebe & Co., Inc., 109 W. 57th St., New York
Factory: Richmond Hill, N. Y.
Western Branch: 443 So. San Pedro St., Los Angeles, Cal.

This company owns and operates stations WAHG and WBOQ; also low-wave rebroadcasting stations, mobile WGMU and marine WRMU.

The GREBE SYNCHROPHASE

TRADE MARK. REG. U.S. PAT. OFF.

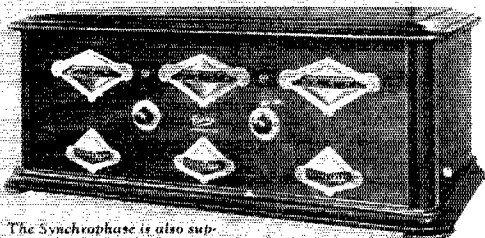

The Synchronphase is also supplied with battery base.



All Grebe apparatus covered by patents granted and pending.

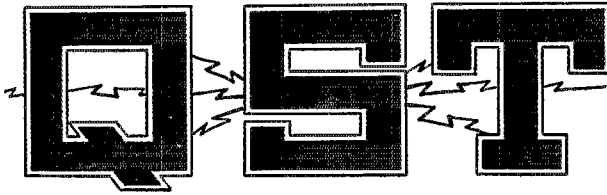

The Official Organ of the A.R.R.L.

VOLUME X

FEBRUARY, 1926

NUMBER 2

Editorials	7
New Phone Band Authorized	8
Three More Cups Offered	8
Book Reviews	8
Horizontal Reception	9
When the Antenna Halyard Breaks	<i>Robert S. Kruse</i> 9
Short-Wave, Plug-In-Coil, Receiver Design	<i>L. B. Hallman, Jr.</i> 17
The New DeForest Tube	<i>F. J. Marco</i> 18
Battery Substitutes	22
Easier Tuning	<i>Robert S. Kruse</i> 23
Easy Money for Ham Tuner Designs	32
Central Division Convention	33
A Zero Weather Mast	33
Filtering the Synchronous Rectifier	34
Experimenters' Section Report	<i>Chauncy Hoover</i> 35
A Good Hydrometer	37
Calibrating Your Wavemeter From a Quartz Crystal	38
A. C. Relays	<i>John M. Clayton</i> 39
Entering Radio Engineering	<i>Harold P. Westman</i> 42
A Resistance Coupled Amplifier	<i>Robert S. Kruse</i> 44
Receiving Conditions in England	45
A Single-Control Rig	<i>W. M. Bakewell</i> 46
Standard Frequency Schedules	47
Dakota Division Convention	47
Amateur Radio Stations SNY 1BAY, 5LG-5SC	48
I.A.R.U. News	51
Calls Heard	55
Communications	58
QST's Directory of Advertisers	95

Official Organ of the International Amateur Radio Union

QST is published monthly by The American Radio Relay League, Inc., at Hartford, Conn., U. S. A.

Robert S. Kruse,
Technical Editor

Kenneth B. Warner (Secretary, A.R.R.L.)
Editor-in-Chief and Business Manager

Edwin Adams,
Advertising Manager

John M. Clayton,
Asst. Technical Editor

F. C. Beekley,
Managing Editor

David H. Houghton,
Circulation Manager

Subscription rate in United States and Possessions, Canada, and all countries in the American Postal Union, \$2.00 per year, postpaid. Single copies, 25 cents. Foreign countries not in American Postal Union, \$2.50 per year, postpaid. Remittances should be by international postal or express money order or bank draft negotiable in the U. S. and for an equivalent amount in U. S. funds.

Entered as second-class matter May 29, 1919, at the post office at Hartford, Connecticut, under the act of March 3, 1879. Acceptance for mailing at special rate of postage provided for in section 1103, Act of October 3, 1917, authorized September 8, 1922. Additional entry as second-class matter, acceptable at special rate of postage provided for above, at Springfield, Mass., authorized September 17, 1924.

Copyright 1926 by the American Radio Relay League, Inc., Title registered at United States Patent Office.
Member of the Radio Magazine Publishers' Association.

THE AMERICAN RADIO RELAY LEAGUE

The American Radio Relay League, Inc., is a non-commercial association of radio amateurs, bonded for the promotion of interest in amateur radio communication and experimentation, for the relaying of messages by radio, for the advancement of the radio art and of the public welfare, for the representation of the radio amateur in legislative matters, and for the maintenance of fraternalism and a high standard of conduct.

It is an incorporated association without capital stock, chartered under the laws of Connecticut. Its affairs are governed by a Board of Directors, elected every two years by the general membership. The officers are elected or appointed by the Directors. The League is non-commercial and no one commercially engaged in the manufacture, sale or rental of radio apparatus is eligible to membership on its Board.

"Of, by and for the amateur", it numbers within its ranks practically every worth-while amateur in the world and has a history of glorious achievement as the standard-bearer in amateur affairs.

Inquiries regarding membership are solicited. A bona fide interest in amateur radio is the only essential qualification; ownership of a transmitting station and knowledge of the code are not prerequisites. Correspondence should be addressed to the Secretary.

OFFICERS

President
HIRAM PERCY MAXIM
Hartford, Conn.

Vice-President
CHAS. H. STEWART
St. David's, Pa.

Traffic Manager
F. H. SCHNELL
Hartford, Conn.

Canadian Gen. Manager
A. H. K. RUSSELL
6 Mail Bldg.,
Toronto, Ont.

Treasurer
A. A. HEBERT
Hartford, Conn.

Secretary
K. B. WARNER
Hartford, Conn.

DIRECTORS

Dakota Division
C. M. JANSKY, JR.
Dept. of Elec. Eng., U. of M.,
Minneapolis, Minn.

Delta Division
BENJ. F. PAINTER
424 Hamilton Nat'l Bank Bldg.,
Chattanooga, Tenn.

Hudson Division
DR. LAWRENCE J. DUNN
480 East 19th St.,
Brooklyn, N. Y.

Midwest Division
PORTER H. QUINBY
Box 134A, Route 6,
Omaha, Neb.

New England Division
DR. ELLIOTT A. WHITE
Dartmouth College
Hanover, N. H.

Northwestern Division
K. W. WEINGARTEN
3219 No. 24th St.,
Tacoma, Wash.

Pacific Division
ALLEN H. BABCOCK
65 Market St.,
San Francisco

Roanoke Division
W. TREDWAY GRAVELY
508 Main St.,
Danville, Va.

Rocky Mountain Division
PAUL M. SEGAL
c/o District Attorney,
West Side Court Bldg.,
Denver, Colo.

Southeastern Division
HARRY F. DOBBS
c/o Dobbs & Wey Co.,
Atlanta, Ga.

West Gulf Division
FRANK M. CORLETT
2515 Catherine St.,
Dallas, Tex.

President
HIRAM PERCY MAXIM
Drawer 4,
Hartford, Conn.

Vice-President
CHAS. H. STEWART
St. David's, Pa.

Canada
A. H. K. RUSSELL
6 Mail Bldg.,
Toronto, Ont.

Atlantic Division
DR. EUGENE C. WOODRUFF
234 W. Fairmount Ave.,
State College, Pa.

Central Division
GLYDE E. DARR
137 Hill Ave., Highland Park,
Detroit, Mich.

Address General Correspondence to Executive Headquarters, Hartford, Conn

EDITORIALS

Looking Backwards a Bit

THE other day we grabbed up our portable typewriter and a few papers and slipped over home to bat out a little magazine copy free of the interruptions of the office. The youngster and the puppy made so much QRM that we QSY'd up into the attic. There in complete and blissful solitude we locked ourselves in and started work.

First we needed a reference from a pre-war number of *QST* so we opened up our bound copy of the early issues. Something caught our eye and we started to read. That was our undoing. We spent the whole blessed day in the attic reading once more the story of our American Radio Relay League through the years of 1916 and '17.

It is a wonderful story that those pages chronicle. They tell of the birth and growth of an idea; they record the first faltering footsteps of our League as the idea took hold amongst the amateurs of the country; the hard bumps and the growing pains of our childhood days are there plainly discernible; our triumphs and our aspirations of those days are enthusiastically reported. We were as much thrilled at reading the story anew as we were when those issues reached us monthly back in the days when we were trying to hold down a relay appointment on old Trunk Line E in a little town out in the Middle West. The former secretary chortles with glee when the League membership reaches the astounding total of 963. Some hardy soul proposes a trans-continental relay. Months later the relay actually occurs, in one hour and twenty minutes, and the president grows bold enough to suggest that some day it might happen in no more than twenty minutes. The proud day arrived when we had "several hundred stations that can work nearly 1000 miles."

And then the *QST* Editor of that day got to wondering. We want to quote part of an editorial that appeared in *QST* nine years ago this month, entitled "Where Are We Bound?":

"Has it occurred to any of you fellows where this relay message traffic is likely to lead us? It is one of the subjects we frequently get onto around the table here at Headquarters when we talk things over.

What is it all going to end in? Here we are, some five thousand amateur wireless operators, engaged in handling real traffic every night in the week. Some stations handle twenty or thirty messages in a single night. They give up four or five hours of good hard work at the key receiving and transmitting messages from every part of the country. Their operating room looks like a real telegraph office and they work like real telegraph operators. When you see them with their sleeves rolled up and the inevitable pipe smoldering away, and the messages coming in and going out in a steady stream it makes you stop and think.

"If the Government continues its policy of paternal encouragement to us amateurs, there is no telling where we will go. We already have receiving apparatus a long way in advance of the average commercial receiving equipment. We do not think anything at all of communicating one thousand miles with a power input of one kilowatt or under, and a wavelength between two hundred and three hundred meters. Twenty or thirty of us do this thing every night in the week. We wonder if a general communicating system will develop whereby the private citizen will be able to communicate with any other private citizen a long distance away without its costing anything? . . . We wonder if the ever increasing demand for amateur apparatus will lead the manufacturers to develop more and more sensitive apparatus until all of us easily hear Honolulu, Japan, South America and Europe? We wonder if new and valuable patents on short wave apparatus for amateur use will develop and alter the existing patent monopoly on wireless manufacture? We wonder if the tremendous industrial advantage which our country will enjoy if the amateur is encouraged will lead foreign countries to modify their rigid suppression of the amateur wireless operator and eventually end in its being possible for us amateurs here in America to 'work' amateurs in foreign countries? And last of all, we wonder if you and I some night in the future will sit in our little room and chat with another fellow in Germany or France while we listen to what is going on between a couple of fellows, one in Brazil and the other in Honolulu? We realize this last is a pretty good 'wonder' but if we advance as much in the next ten years as we have in the

past ten, it will be something to confidently expect."

Will you believe it? We don't know whether we think it's more amazing that these things have come to pass or that no longer ago than 1917 they were regarded as subjects only for vague speculation!

We wonder—wait a minute. We want to say that we're only speculating too. We wonder where we'll be in nine years more? We wonder if we will be employ-

ing our 75-cm. wave then for a new order of achievements? We wonder if we will have radio vision perfected? We wonder if we will have overcome fading and static? We wonder if we will be able to continue to add to the spirit and enthusiasm and brotherhood of Amateur Radio until it completely encompasses the globe? We shall have to step some to keep up with the record of the last nine years.

—Kenneth Bryant Warner.

New Phone Band Authorized

ACTING at the recommendation of the Fourth National Radio Conference, the Department of Commerce on December 7th issued General Letter No. 274 to all Supervisors and others concerned, reading as follows:

"The existing amateur regulations are hereby amended to include authority for the use of radiotelephone equipment within the wave length band between 3500 and 3600 kilocycles (85.66 and 83.28 meters), in addition to use of the band for this service between 170 and 180 meters, at present authorized."

It will not be necessary for amateurs desiring to use the new phone band to return their station licenses to the Supervisor for endorsement. The Supervisors upon request will issue to each applicant a letter authorizing the desired operation. It is very necessary, however, that the request be made of the Supervisor, so that his records may show the authorized operation for each station.

The Bureau informs us that no action has yet been taken on the recommendation of the Conference to discontinue the licensing of amateur spark apparatus, pending the conclusion of a survey now being made.

K. B. W.

Three More Cups Offered

MR. J. C. Cooper has offered three more cups, to be given for work that will help the radio art in the 5-, 20- and 40-meter bands.

The exact time limits and the complete conditions have not yet been worked out but they will be announced in the next issue of *QST*. We are sure now that the cups will be given for work which improves the radio art. If you know of anyone who is doing such work by all means make sure that he prepares to enter for one of the cups. The men that do the worth-while work are usually too busy or too modest to enter a contest unless they are urged.

Bring this thing up at your next club meeting and make sure that your state will be represented. Meanwhile watch March QST for the complete announcement.

BOOK REVIEWS

By Robert S. Kruse, Technical Editor

Wireless Telephones and How They Work, by James Erskine-Murray. Crosby Lockwood & Son, Stationers' Hall Court, Ludgate Hill, E.C. England, Third Edition, Price \$1.50.

It is pleasing to have injected into the drab stream of current radio literature one book by an author who is able to use the English language without effort. When that man in addition is an authority on his subject the effect is wholly pleasing.

In the 78 pages of the text and the three pages of the glossary the author has, in a pleasantly conversational manner, made exceedingly plain and easy to understand the general basis upon which radio telephone operates. By the word "conversational" I mean nothing that is not complimentary. I do not imply that he descends to the current American habit of being slangy or cheaply humorous. No, this conversation is an intelligent one.

The interest of the little book is perhaps raised by the fact that it is written from the English standpoint and that both the words and the mental attitudes are rather unusual to us.

The book suffers from one thing only. The illustrations are distinctly sketchy in their character and would be much improved if the photographs came under the care of a skilled re-toucher and the circuit diagrams under the pen of a professional draftsman before the cuts were made.

The International Amateur Radio Call Book. International Call Book Company, Drawer 205, Sta. "A," Hartford, Conn. Edition November 1, 1925; Price fifty cents.

Any review of a call-book is of necessity mere conversation because the usefulness of a call-book depends on its accuracy and completeness which can be determined only by putting it to use for some months.

One can however, say that this book is most commendable as being the first effort to produce an International Call Book, all previous efforts having been so weak as to be unworthy of mention. This is natural because previous attempts have been made by unsatisfactory organizations, considered from this standpoint. The present book contains information collected through the channels of the American Radio Relay League and the International Amateur Radio Union.

Horizontal Reception

By Robert S. Kruse, Technical Editor

I HAVE discovered," says Dr. Greenleaf W. Pickard in the *Boston Herald*, "principally through measurements made at my Seabrook analyzer station, an entirely new fact; the short waves, unlike the long, do not remain vertical after leaving the transmitter, but after travelling 20 or 30 miles are in a large part twisted around so that they are horizontal.

"A vertical wave is naturally best received by a vertically acting antenna; that is, the usual elevated wire and ground connection. An ungrounded, horizontal wire, with the receiver at the center, responds very feebly to vertical waves, and, if the wire is placed at right angles to the direction of the distant stations, it will not receive at all.

"A horizontal wave, on the other hand, is without substantial effect upon the ordinary vertical antenna, but is best received by a horizontal wire, at right angles to the distant transmitter, and well off the ground.

"At the Seabrook analyzer station you will see that a straight ungrounded wire is used for reception, mounted so that it can be rotated or swung into any position. This wire is cut at its middle, and tuning and amplifying apparatus are inserted at this point.

"When wavelengths of the broadcasting band or of greater length are measured by this apparatus, they are always found vertical, polarized by day with no measurable trace of horizontal component. But in the evening, although the major part of the wave is still vertical there is a distinct horizontal component amounting to between 5 and 10 per cent of the vertical.

Important Findings

"When the short waves, 80, 40 and 20 meters, are thus measured, it is found that the greater part of the wave arrives horizontally polarized. At 80 meters an aver-

age for the past four weeks is two-thirds horizontal and one-third vertical. For waves in the 40-meter band the average is four-fifths horizontal and one-fifth vertical.

"These results may well revolutionize our short-wave receiving methods. Instead of using any form of antenna and ground, we may place our station on a lower tower, and receive a pair of horizontal wires. Not only will the signal be stronger, but there will be materially less static on such a receiver for I have found that static at the short wavelengths is about equal horizontally and vertically, while the signal wave is much stronger horizontally. The gain in signal-static ratio on horizontal reception may run from two to four times—an amount well worth having."

Isn't that about the most worthwhile announcement concerning short waves that has been made in a number of years? It seems that way to the writer and therefore the story will be told with some detail.

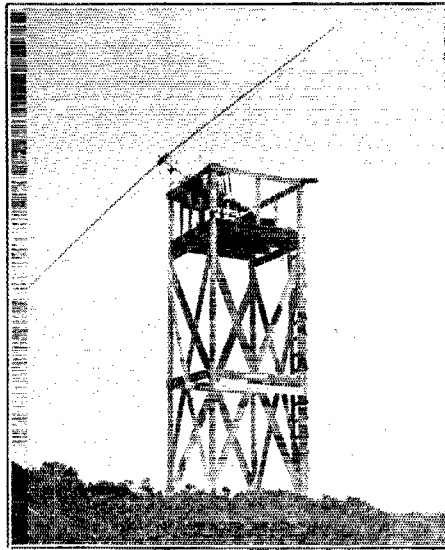

DR. PICKARD'S SEABROOK BEACH ANALYZER STATION

The analyzer station at Seabrook Beach consists of a wooden tower 18 feet high with a 6"x6" platform on top. At one corner of this platform is a post carrying a universal joint which in turn carries a 30-foot wire broken at its center by a tuning coil. This wire forms a linear oscillator which can be rotated or tilted in any direction and can be tuned to anything from broadcasters down to the 20-meter band.

Dr. Pickard's Experiment

During July of this past summer Dr. Greenleaf W. Pickard set up at Seabrook Beach, N. H., the peculiar receiving station shown in our photographs. The pur-

pose of the installation was to find out what the shape of radio waves was when they reached Seabrook Beach. Now it would have been simple enough to use an ordinary radio compass (loop with scale of directions) to find out from which point of the compass the signals came, but that wasn't the main point of interest. The idea was not only to find out from which *direction* the signals came, but also whether the waves were bent in any fashion, and whether they leaned backward or forward or possibly whether they came down from above instead of going across the land-

scape. That can be done most conveniently by working on the electrical part of the incoming wave. There are two parts to the problem because there are two parts to the wave. All of us are used to hearing about "Electro-magnetic waves" but most of us never stop to think just what this is supposed to mean.

The Electro Magnetic Wave

A little theory is necessary to explain this whole business. The theory isn't particularly painful and there is no mathematics about it so the reader shouldn't dodge this part.

To make this explanation work we must begin by agreeing that there really is such a thing as a radio wave. There are plenty of people who don't believe that there is and I'm not too sure about it myself. However it saves discussion to tell about the whole story in terms of these radio waves. Very well; now let's consider a Hertzian antenna.

The Hertz Antenna

So many weird things have been getting called "Hertz antennas" or "Hertzian antennas" that it's well to start out by getting straight on just what the thing is. In Figure 1A is shown a proper Hertzian antenna. It consists simply of two pieces of metal rod placed in line with each other and provided with metal balls. The balls close to each other (G1 and G2 in Figure 1A) form a spark gap. The two balls C1 and C2 on the open ends of the system serve as capacities. Leads L1 and L2, run to a spark coil, static machine or vacuum tube which serves to excite the whole thing. This was Hertz's transmitter and a

leads until the spark gap G1, G2 broke down after which the thing oscillated briefly after the fashion of spark antennas. Then the spark stopped and the whole business began over again. Nowadays we usually operate this same affair without any gap at the middle because the power is supplied by a vacuum tube which operates all the time and doesn't need to stop and

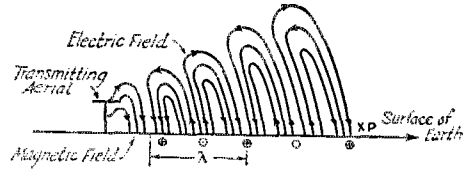

FIG. 2
THE FIELD RADIATING FROM AN ANTENNA WITH A GROUND CONNECTION.

save up energy before it can go off once more. However it is simpler to explain the thing in terms of Hertz's original device and therefore we will stick to it.

The Hertzian Oscillator

Suppose that we have changed the system as in Figure 1B. The upper half of the system is positive and the lower half negative. There is an electrical strain between them because the two charges attract each other. Therefore we have an electrical field such as is shown by the arrows. No current is flowing and therefore there is not any magnetic field.

The Magnetic Field

Now suppose that the gap breaks down in a spark as at Figure 1C. Current starts to flow, first slowly and then more rapidly. When the current has become largest there is practically no electrical charge left on the two halves of the system and therefore the electrical field has disappeared. However there is a field just the same, a magnetic field this time. The magnetic field is there because any wire carrying a current has a magnetic field around it. This field is represented by the circular arrows running around the wire in Figure 1C. Of course the current can't keep running in the same direction forever because there wasn't very much electricity present to start with. Pretty soon, therefore, the current dies down and stops. Now we have the thing charged again, except that it is in the reverse direction, the lower half being positive while the upper half is negative. Therefore a picture of the affair would look the same as Figure 1B excepting for the positive and negative marks which are re-

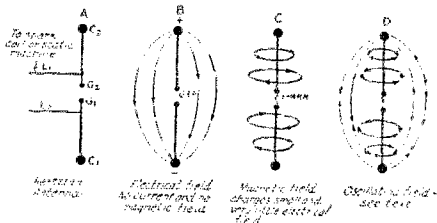

FIG 1

THE ELECTRICAL AND MAGNETIC FIELD OF A HERTZIAN TRANSMITTER.

very simple little transmitter it is. One can see fast enough that it is nothing but a very small antenna-counterpoise system. As Hertz used it the two halves of the system were charged by means of the spark coil or static machine connected to the two

versed and also the arrows which are pointed upward instead of downward.

Then the spark gap breaks down again and we have a current in the reverse direction from that of Figure 1C. Therefore the picture will look the same as 1C excepting that the arrows will go around the wire in the opposite direction.

The Electro-Magnetic Field

We have now talked about the *electrical* field (sometimes called the static field because the electricity is stationary at the time) and about the *magnetic* field. The next question is where then does this "electro-magnetic field" come from?

The answer can best be shown by explanation.

We have talked as if the things shown in Figure 1B and 1C happen quite slowly. Of course they don't do anything of the kind but happen at a tremendous rate so that we are quite unable to see them happening separately, one after the other. Therefore, if we could actually *see* the dif-

ferent fields we would see a combination looking like Figure 1D where we have magnetic fields rotating in both directions and electrical (or static) fields pointing both up and down. We are therefore justified in saying that the actual field around an oscillating antenna system is a composite affair having both electrical and magnetic parts.

row Figure 2 outright from a very excellent article by Mr. R. L. Smith Rose and Mr. R. H. Barfield in the September issue of *Experimental Wireless and the Wireless Engineer (British)*. This article, by the way, is on the same general subject we are talking about now and makes mighty interesting reading. It is called "Some Measurements on Wireless Wave Fronts".

In Figure 2 there is shown the system of electro-magnetic waves leaving an antenna. For the sake of making the figure simple, the antenna has been shown when used with a ground connection. This means that we will only get the upper half of the picture which appears in Figure 1, the lower half being inside of the earth, or perhaps missing altogether.

The Loop

The use of the loop to determine the direction from which the waves are coming toward the receiving point has been mentioned before. We needn't go into that any further than to say that the loop works on

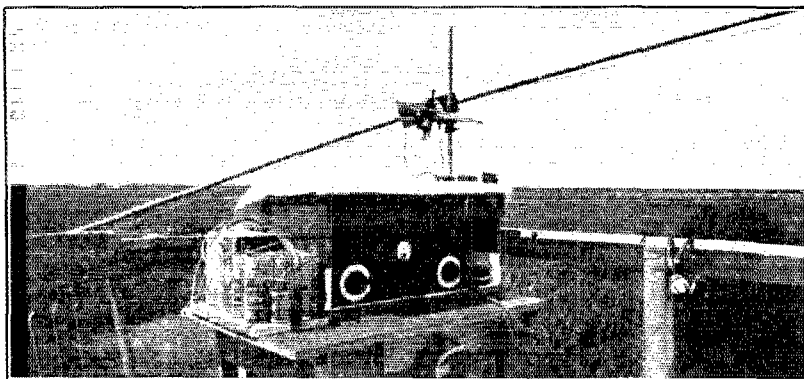

DETAILS OF THE RECEIVER

The tuning coil is coupled to a shielded super-heterodyne receiver with a local oscillator beating against the intermediate frequency.

ferent fields we would see a combination looking like Figure 1D where we have magnetic fields rotating in both directions and electrical (or static) fields pointing both up and down. We are therefore justified in saying that the actual field around an oscillating antenna system is a composite affair having both electrical and magnetic parts.

The Electro-Magnetic Wave

These fields do not simply grow and die near the wire. They go out in all directions from it. Because they expand away from the antenna in all directions along more or less straight lines we call this process "radiating". It seems helpful here to bor-

row Figure 2 outright from a very excellent article by Mr. R. L. Smith Rose and Mr. R. H. Barfield in the September issue of *Experimental Wireless and the Wireless Engineer (British)*. This article, by the way, is on the same general subject we are talking about now and makes mighty interesting reading. It is called "Some Measurements on Wireless Wave Fronts".

The Hertz Receiving Antenna

Now if we wanted to know the direction from which the electrical (static) field were coming we would need something besides a loop. Since the antenna system is able to start electric fields as well as magnetic ones, we naturally think of using some kind of a directive antenna which shall be influenced as little as possible by the magnetic field and as much as possible by the electrical field. Of course it will not be

practical to use a receiving antenna tied to the earth because you can tilt the antenna around but it is difficult to tilt the earth around with it. Therefore we use a miniature antenna and counterpoise system, put in a straight line so as to give our best directive effects. This means simply that we are going to use a Hertzian receiving antenna.

The Hertzian Compass

Referring to Figure 3, if we imagine the little heavy line with a box at its center to be a Hertz antenna with a receiving set in the middle, we have all of the apparatus needed to find out the angle at which the electrical field is approaching our receiving set. By looking back at Figure 1B and at Figure 2 we will see that the electrical field will probably be vertical near the earth. This is generally the case with the longer wavelength at least. If we look at the upper part of Figure 3 ("vertical electrical field") we will see some arrowhead lines representing this electrical field. It is supposed to be marching across the paper to the left. At A is shown our Hertzian compass placed vertically. Since there is a vertical electrical strain this means that the upper end of the system will be charged alternately, negatively and positively as

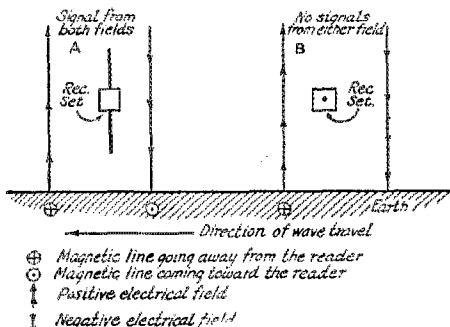

FIGURE 3 THE HERTZIAN COMPASS.

The field shown is an undistorted one such as would be received in open country by daylight from a fairly long wave station.

the lines 1, 2, 3, etc., go wiping across it. This happens at radio frequency and the result is a radio frequency current through the receiving set in the box at the center of the antenna system. The magnetic field also contributes to this voltage. If the field from our distant antenna is undistorted we are now in the position for the strongest signal. If the antenna system is now laid down as shown at Figure 3B we are in a position where neither one of these fields will produce any effect on the antenna.

Distorted Fields

If either the electrical or the magnetic field is distorted it will be necessary to

change the position of the antenna in one way or another to get a zero signal. It is quite difficult to explain on paper just how the variations in each case affect the position to which the antenna must be placed. But one can see fast enough that it will happen. If one is interested in repeating the experiment a little thought, plus a model made of string, wires and pencils (or whatever other junk is handy), will make the thing clear.

At Seabrook Beach

An apparatus like the one described was set up at Seabrook Beach, N. H., by Dr. Pickard. The receiving set was not in a box at the center of the antenna but was placed in a shielded cabinet as shown in the photograph and the leads to it were shielded. This was more convenient and the effect was the same.

Dr. Pickard and his assistant, Mr. Earl Prescott, of Station 1BBK at Newburyport, Mass., sat at the top of the tower, plagued by the famous New Hampshire mosquito, and "shot" the direction of incoming electrical fields from short wave stations.

Quoting from a letter of Mr. Prescott's "Nearly every night 45 to 75 stations were logged. Only the stations with the greatest volume were logged as the weaker ones could not be measured accurately. Stations on the 20-, 40-, 80- and 150-meter bands as well as the broadcast waves were measured. 40-metetr and 80-meter stations were used mostly. Only one station on the 20-meter band could be logged as none of the others were ever heard to sign. Another thing; *for once the CQ man was useful!* The biggest part of the stations logged were stations that were calling CQ and keeping at it long enough so that measurements could be made. Stations that put in their calls at the end of their transmissions were found to be very useful. No consistent long distance work was logged but a South African and a German amateur were copied.

Schedules with IRV in Hamilton (150 meters) and ICE of Haverhill (80 meters) were arranged and carried out. A schedule was arranged with 1AHZ of Haverhill at 80 meters but we were unable to hear him. (No reflection on the station but on the conditions.—Tech. Ed.) My own station 1BBK at Newburyport (6 miles) was also used at a wavelength of 80 meters and operated by ex-1GW. It was found that during the day with a vertical antenna my signals were not audible but at night they could be heard".

Now there is nothing new about this sort of a thing on longer wavelengths. For those who are interested in the history of the thing, a short reference list is given at the close of this article. However, previous

workers had been operating at waves so long that there was not a great deal of likelihood of very great distortion of the wave front. These longer waves are known to be pretty regular in all of their functionings.

On the other hand the short waves are known to change their character as they go away from the transmitting station and it seems entirely likely that some of this was due to a leaning of the wave front.

Dr. Pickard's Story

From this point on we will let Dr. Pickard tell his own story. It is taken from a letter to the writer of this paper.

"The Analyzer station at Seabrook, made 1300 measurements of 379 stations, principally in the period from one hour before, to two hours after, sunset. The majority of the stations measured were operating in the two frequency bands of 3.5 to 4.0 and 7.0 to 8.0 megacycles (80 and 40 meters). These stations were all of the antenna-ground or antenna-counterpoise type, operating either at the fundamental of the antenna system, or at a harmonic, so that the wave left the transmitter vertically plane-polarized.

"The measurement made was that of the ratio between the horizontal and the vertical electric forces in the wave front at the receiving point. In all cases the maximum amplitude was found either horizontal or vertical, and the minimum amplitude at right-angles thereto!: there was no instance where the maximum and minimum electric force axes made any appreciable angle with either the vertical or the horizontal. This is probably because the earth acts as a reflector to radiation coming down from above, and the resonator, mounted only a short distance above the surface, measures the resultant of the incident and the reflected beam, so that a wave with its plane of polarization at, say, 30° from the horizontal, would be resolved into a truly horizontal field of amplitude 2, and a truly vertical field of amplitude 1.

"The majority of the stations measured were in the United States, although a number of Canadian and European stations were also picked up and measured. One station (which has as yet to be confirmed) was A4Z in South Africa. Many measurements were also made of high frequency commercial land government stations, such as the AGA at Nauen, Germany, etc., etc. Special measurements of radiation which was emitted horizontally polarized were also made, and will be described below.

"The first analysis which I have made of my data is the relation between horizontal/vertical amplitude and distance. This is given in the tabulation below for two of the frequency bands measured, and irrespective of direction. In this tabulation only

the measurements made in the period from one hour before to two hours after sunset are included.

For the frequency band 3.5 to 4.0 megacycles.

Distance Kilo- meters	Number of Measurements		Vertical 1:0.77.
	Horizontal	Vertical	
30	0.3	18	In this band the average static ratio for the month was 2:1 vertical to horizontal.
62	2.0	32	
90	2.1	27	
154	2.3	38	
205	2.3	32	
290	2.4	14	
350	1.6	84	
542	1.4	65	
1050	1.5	12	
1610	1.8	35	

For the frequency band 7 to 8 megacycles.

58	4.0	12	In this band the average static ratio for the month was equal, horizontally and vertically.
115	4.5	19	
219	5.0	18	
337	3.9	103	
547	3.1	115	
1000	1.7	23	
1610	1.8	35	

"At greater distances the ratios given above for 1050 and 1610 kilometers are exceeded; that is, the curve seems to rise again, although it never reaches the maximum attained for distances between 200 and 300 kilometers. For example, AGA at Nauen, Germany, working at 11.5 megacycles, gave an average value of 2:1, horizontal to vertical. O4AZ, at 7:9 megacycles, gave on a single measurement a ratio of 3:1, horizontal to vertical.

"An analysis of my data for the above two frequency bands according to direction,

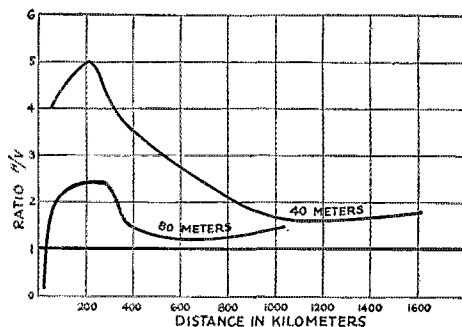
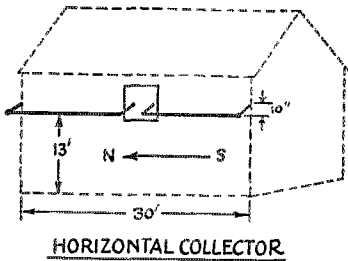

FIGURE 4 THE POINT OF THE WHOLE STORY. Curves showing the strength of the horizontal component compared to the vertical component at different distances. Horizontal reception is of advantage whenever the curve is above the heavy line marked "1."

that is, with respect to the magnetic meridian, has shown no change in the horizontal/vertical ratio for stations at the same distance, but which were grouped both in the magnetic meridian and at right angles thereto. Apparently the polarization effect which I measured was independent of the earth's magnetic field.

Polarized Transmission

“Special measurements were made of radiation from Schenectady, 250 kilometers distant, which was alternately horizontally and vertically polarized at the source, by the use of well-elevated horizontal doublets¹ for the horizontal polarization, and either a vertical doublet or the ordinary antenna-ground for the vertical. At 790 kilocycles, it made *substantially no difference in the results at Seabrook* whether the wave left Schenectady horizontally or vertically; it was always received with its plane of polarization principally vertical. At 3.75 megacycles, the wave at Seabrook had a ratio of 2.15:1, horizontal to vertical, re-



HORIZONTAL COLLECTOR

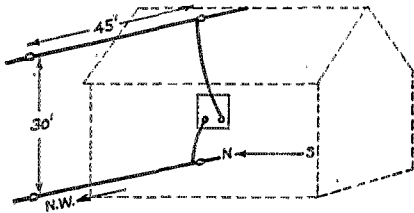

REGULAR COLLECTOR

FIG. 5

ANTENNAS USED BY B. H. TAYLOR AT HAVERHILL, MASS.

gardless of whether Schenectady was sending horizontal or vertical.

“My results might fairly be summed up as follows: The ratio of the horizontal to the vertical electric forces in the wave-front depends upon three factors, which are, in order of importance, frequency, distance and time of day. This ratio is not, save in the immediate vicinity of the transmitter, in any way dependent upon the polarization of the wave at its origin.

“Regardless of distance, all transmission frequencies under one megacycle are received vertically, with no horizontal component, during daylight hours. Under night conditions, frequencies in the broadcasting band show a horizontal component amounting to between 5 and 10 per cent of the vertical.

“At a frequency of 3 megacycles, day time reception is almost purely vertical, but

at night the horizontal and vertical electric forces are nearly equal.

“At still higher frequencies, the tabulation above shows what happens from 3.5 to

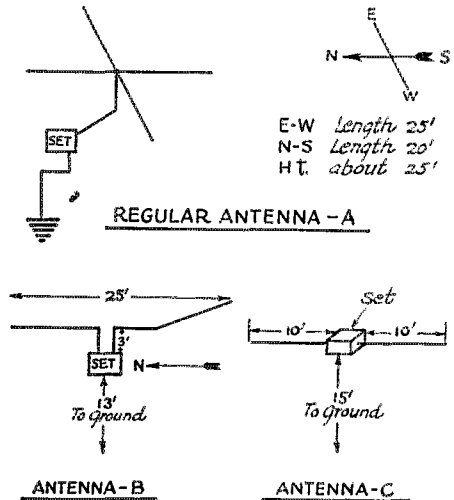

FIG. 6

ANTENNAS TESTED AT 10A, EAST HARTFORD, CONN.

8 megacycles. Above this, although my measurements are relatively few in number, there is only a slight increase in the night time horizontal/vertical ratio, but during the day the ratio increases markedly over that obtained for the lower frequencies.

“On the evening of August 22, 1925, there was a strong aurora, but the measurements showed no effect upon the horizontal/vertical ratios.”

Practical Tests of Horizontal Reception

Mr. B. H. Taylor, Manager of the Postal Telegraph Commercial Cable Office at Haverhill, Massachusetts, talked to Dr. Pickard in the latter part of August. Dr. Pickard suggested that he make a practical test of the horizontal receiving antenna. His story is best told in his own words as quoted from a letter.

The Horizontal Antenna for 40 Meter Reception

“I never heard more than three stations all told in New Zealand on the regular antenna, while with the horizontal antenna eleven New Zealanders were read in a single night. Upon that night but one of those could be heard on the old antenna, and that same one could be copied through the loud speaker with the horizontal antenna. Certain New Zealanders were calling English stations almost nightly on pre-arranged

calls and were promptly answered, and then tests were made by phone from England. On some of these occasions I could not clear up the English music through New Zealand reported very good results, and at other times vice versa.

"The first night I tried out the horizontal antenna I was greatly surprised. 17 California stations were read with no trouble whatever. The signals from the best of these dropped down when switching back to the old antenna, and the most of them were not there at all. On most all relays worked by WAP I was able to get in on the station worked from locals to foreign ports, when I was on the air.

"My arrangement was (see Fig. 5), a total of 34 feet of bell-wire strung along the west side of house on level with the receiving set at a height of about 13 feet above ground, the set being cut in at the middle, about four feet of the wire being in the leads. The bell-wire was attached to sticks about 14 inches long that were tacked to house. No insulators were used. This was but a temporary affair, and will be put up again permanently with a little more thought regarding insulation.

"Directional effect, (the antenna running North and South) seemed hard to identify. On several occasions signals from Mexico City amateurs were nearly as loud as others of the same distance directly West. Also signals came through from Brazil and Chile on one or two occasions readable.

"The night that Mr. Schnell reported NRRL as '2300 miles Southwest of San Francisco' the signals were the best ever heard from him, readable through the speaker. Of course, my set was not quite right for best work owing to a.0025 ufd tuning condenser being used as a combination for broadcast work. However, on most occasions when I got interference I noticed the other fellow got it too. The night that Mr. Schnel sent the convention greetings to Chicago via WAP his signals were good also. He will probably remember that a 2CM tried to follow him through to WAP calling intermittently for half an hour. I also had a log on a U.S. Navy ship in China, but this was not definitely known at that time. Signals from Europe were not so good, although I had a chance to test out on one amateur in Italy, and one or two in Paris, with clearer signals on horizontal from Paris, and not finding the Italian on the old antenna, but finding him again on horizontal.

"My yard is full of large apple trees, one of them with the branches above the antenna on the south end, so I don't believe my conditions here were the best by any means.

"Sorry I am not able to send in the complete log with a long string of copy that I

had got together especially for reference, but, really I thought the matter was passed up. Listening to the telegraph 10 hours a day for so many years makes it hard to recall things that are so common. I surely believe the thing works out better, and will start in again shortly with a better set and try to improve upon the horizontal idea."

It is always well to have as many checks as possible on anything that looks like a new radio phenomenon. Therefore the author of the present article, having heard of the results secured, made some check tests at his home in East Hartford. At the time

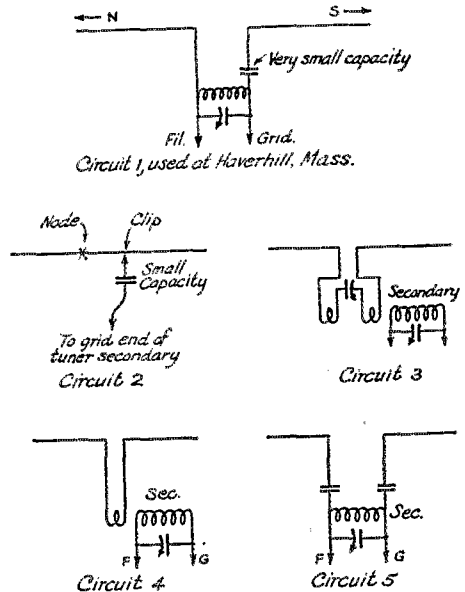

CIRCUITS USED AT 10A, EAST HARTFORD, CONN.

FIGURE 7

RECEIVING CIRCUITS TESTED IN HORIZONTAL RECEPTION.

The tuner in all cases was an ordinary autodyned detector affair, requiring no separate description.

Tests at East Hartford

that the work began the weather was extremely unpleasant, rain falling steadily for days on end. Because of this, and also limited yard space, the work had to be done indoors. This naturally raised the suspicion that the wiring in the house might confuse the results very greatly and a good deal of thought was put on getting away from this effect as far as possible. First all the wiring in the house was traced so as to find a portion of the building as free as possible from these effects. The first thing was, of course, to get a reference antenna against which to try out the horizontal reception. The attic of the house is comparatively free of

wiring; therefore a non-directional antenna like that of Figure 6A was put up. As city locations go, the house is fairly well clear of overhead wires on poles. Possible trouble from other antennas was prevented by taking them down entirely.

This antenna was first tried during several nights to find out what its average performance was like. It seemed to give good average reception on the 40-meter band, where all of the following work was done.

An antenna like Figure 6B was now stretched through the second floor of the house, a slight kink being necessary near the south end to get through a doorway. The odd height is due to the necessity of keeping between the ceiling and the floor so as to avoid the house wiring as much as possible. To avoid effects from the antenna in the attic a clip was provided at the point X in Figure 6A and the lead below this point was removed entirely whenever the horizontal antenna was in use. This represented cutting off the antenna at the ceiling of the second floor. The ground lead could not be removed because it was the piping of the hot water system and therefore permanent.

Antenna 6B gave performance very greatly superior to that of antenna 6A on any 40-meter station more than a short distance away. This is just what should happen in accordance with the curve of Figure 4. From this curve one can see that the voltage applied to the horizontal antenna (if it is of about the same size as the vertical antenna) should be two times or more that gotten from the vertical antenna. Of course the detector will give considerably more than twice as loud a signal because of its peculiar "law of response". This also was the case. Many stations that could barely be heard with the vertical antenna were quite loud with the horizontal one.

Unfortunately the number of stations that one could work on was limited because it took quite a little time to shift from the one antenna to the other and it was more or less luck when the same station was heard again. The actual useful results depended on about a dozen stations although a great number of others was heard.

The Portable Antenna

At this point there began to be a suspicion that the house wiring had a good bit to do with the thing. Being alone one evening so that it was possible to upset the household without interfering with anyone, I rigged up an affair like that shown in Figure 6C, the two halves of the antenna being lengths of metal tubing fastened to a base-board on which the set was built. This awkward affair was then maneuvered

around through a narrow hallway to find out if there were any great directional effects. This proved entirely too slow and the whole rig was lowered from the window and the attempt repeated in the garden. Surprisingly enough the directional effects were very weak although the signal strength was excellent. Another rain put an end to this experiment after less than an hour. The important point is, however, that with this small collector at a height of less than five feet from the ground, the signal strength on many stations was fully equal to that of the antenna 6A.

Circuits

Concerning Figure 7 it is not necessary to say a great deal except to point out that circuits like No. 2 and No. 4 in Figure 7 have the disadvantage that the collector itself has a decided natural period which may or may not be right. I am inclined to favor circuit 5, making each of the small capacities about 5 micromicrofarads. However, as Don Wallace says, "The best circuit for you is the circuit you like the best".

Following Up

Now then, this thing may still be a false alarm for general practice. A good many of the readers will remember that this magazine was guilty of assisting in creating the impression that wavelengths around 20 meters were good in daylight only. It turned out afterward that the distance and the season of the year and the time of day must all be considered. Perhaps the best illustration of the fact that waves around 20 meters are good for something in daylight is that in the memorable Telefunken test extremely strong signals were put into the United States at wavelengths between 20 and 25 meters during daylight and that the same signals were weak or inaudible at night.

Because such mistakes can occur it is very important that as many as possible of us check this thing up and communicate our experiences to the magazine. Just one caution; *don't* send in one of these meaningless lists of "calls heard." What is necessary is a *comparison* between the results obtained with a horizontal antenna and an ordinary antenna. The performance of either one alone is perfectly meaningless.

The following reference list is copied from the article "Some Measurements on Wireless Wave-Fronts" by R. L. Smith-Rose and H. Barfield, page 737, *Experimental Wireless & The Wireless Engineer*, September, 1925.

L. W. Austin.—"The Wave-Front Angle in Radio Telegraphy."—*Journal*, Washington Academy of Science, 1921, Vol. 40, pp. 101-106.

J. Erskine-Murray and J. Robinson.—“An Improved Method for Determining the Direction of Propagation of Electromagnetic Waves.”—British Patent 176, 127/1921.

E. Bellini.—“Frame Aerials and Errors in Bearings.”—*Electrician*, 1922, Vol. 89, pp. 150-1.

H. B. Jackson.—“Directional Effects with Frame Aerials.”—*Wireless World and Radio Review*, 1922, Vol. 1, pp. 789-800.

Some work of this kind has also been done by Dr. A. H. Taylor at the Naval Research Laboratory, Washington, D. C., but no reference is available.

When the Antenna Halyard Breaks

By L. B. Hallman, Jr.*

IN these days of small antennas and shorter waves the need for schemes to get an antenna back to the top of an 80 ft. pole after the rope has broken may not seem so great. However, there are many who believe in using large, high antennas and working them at harmonics. Possibly the scheme given below may be found of some value after all.

Early one morning, after a stormy night, the antenna at 5WI was found scattered over the surrounding territory. There was nothing that even looked like a rope anywhere about the pulley at the top. The mast we had, at the time, wasn't strong enough to climb and owing to a number of fences and buildings it was almost out of the question to let the mast down. We set about to get a pulley and rope to the top without either of these alternates.

There were four guy wires at the very top of the pole. One of these could easily be spared for a while, and it was brought down to the foot of the pole and tied. This made a sort of “guide” running from the foot of the pole to the top. A suitable pulley was then secured, threaded with rope and a strong iron hook attached that would “hook” over the top of the pole. It can thus be seen that if we could get this pulley and rope to the top and catch the hook over the pole, everything would be F.B. again, provided the hook is pulled down hard to jam it on the pole. This is where we made use of a wire that had been arranged from the top to bottom of the pole. If there had been none we would have used a guy wire.

Enough small piping (about $\frac{1}{2}$ " or $\frac{3}{4}$ ") was borrowed to reach the top of the mast. To the first piece (which was specially shaped) the pulley was tied with string. We got a step ladder that was as high as one section of the piping was long and attached the first piece of pipe, with the pulley and rope, to the wire that was run-

ning from the ground to the top of the pole. This wire has to be rather taut. The pipe was attached so that it would slide along the vertical wire when pushed (this can be done with pieces of wire). The object of the vertical wire was to act as a guide for the pipe and to hold it straight as

it was going up. This first section of piping was pushed on up the wire till another section or length could be screwed onto it. It can be seen that the pulley, at the top of the first section, being guided by the wire along the pole, was soon pushed to the top. It was pushed a little above, however, and was then turned so

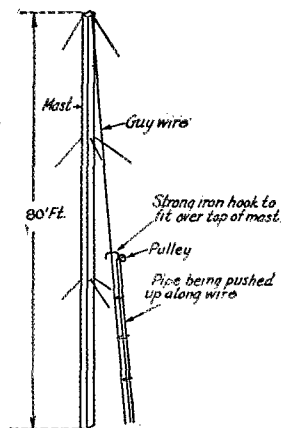

that when it started back down the hook on the pulley would catch over the top of the pole. When it caught, the string that held the pulley to the pipe was broken and the pipe allowed to slide down.

Thus the pulley with the rope threaded in it was left at the top and nothing was anything the worse. The piping can easily be pushed up an 80-foot pole by hand, and I have attached pulleys half-way up using cane fishing poles instead of pipe. The top of our mast was rectangular and of wood. If it had been a pipe mast, however, the hook on the pulley would have been slipped down the hole in the top. The wire we used to guide the pipe was barren of insulators, but if the insulators are not too large they shouldn't cause much trouble.

In conclusion—if the antenna halyard is boiled in linseed oil it will last a lot longer and will lessen the danger of such trouble. The linseed oil is easier to put on than tar and after it dries will not stick to your hands so badly.

Strays

Ellis Wilbrahm of Hartford not only sends out criticism cards to amateurs who are operating in a sloppy manner but he also sends letters of commendation to those few who are doing good operating.

“I next went to the radio room, where every appliance for both radio and wireless was to be found.”—*N. Y. Times, Radio Section.*

*5WI, 508 S. Oates St. Dothan, Alabama.

Short-Wave, Plug-In-Coil, Receiver Design

By F. J. Marco*

THE mere juggling of the number of turns on a coil and the choice of an appropriate tuning condenser is not always productive of the best receiver. Consideration of the losses inherently within the tuning system and also the losses introduced into that system by other associated apparatus such as the detector tube, antenna, adjacent metallic or di-

sponse only, one regenerative circuit is as good as another... Whether we use tuned-plate, ticker-feedback, inductive-capacity-feedback, throttle-control, or any other conceivable system, the signal strength of a distant station will be the same. However, it is always desirable to use the simplest and most stable circuit. Since both tuned-plate and rotating-tickler feedback circuits greatly affect the tuning as the regeneration is changed, the circuit shown in Fig. 1 has been chosen. This is immediately recognized as being very similar to the ordinary form of capacity controlled regenerative circuit and differs only in a slight rearrangement of parts. It is possible, with this system and proper proportioning of constants, to obtain a condition wherein the regeneration control varies only slightly with frequency, thus allowing a single setting of the feedback control to cover a fairly wide band of frequencies. This makes the receiver practically single control and keeps one hand free for copying and logging.

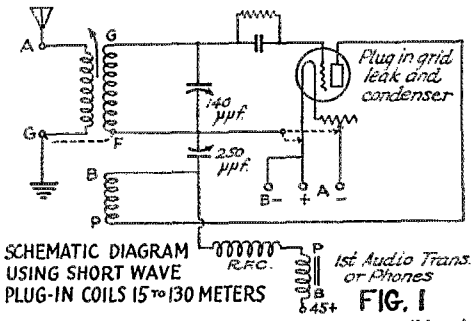

The circuit, chosen from the various possible circuits employing a fixed tickler and a variable bypass or stopping condenser. This particular arrangement gives smooth control of regeneration while at the same time the tuning is practically unaffected by the movement of the regeneration condenser.

electric structures, etc., is extremely important in securing greatest commercial efficiency. It has been stated that, "As long as a regenerative system can be made to oscillate its losses do not matter," and that "Low-loss apparatus is unnecessary in an oscillating circuit." Ballentine, in "Radio Telephony for Amateurs" is very definite in taking the opposite stand, and only recently, (See "An Analysis of Regenerative Amplification, by V. D. Landon and K. W. Jarvis, *Proceedings of the Institute of Radio Engineers*, December, 1925), it has been mathematically and experimentally proved that under practically all operating conditions a reduction of circuit resistance is distinctly worth-while.

The Circuit

The first consideration facing the designer of a radio receiver is the choice of an appropriate circuit. Now, other things being equal, from the standpoint of re-

In the diagram, Fig. 1, A-G is the antenna delivery coil, coupled to G-F, which, with its tuning condenser, constitutes the tuned grid circuit. The filament and grid of the detector tube, thru its condenser

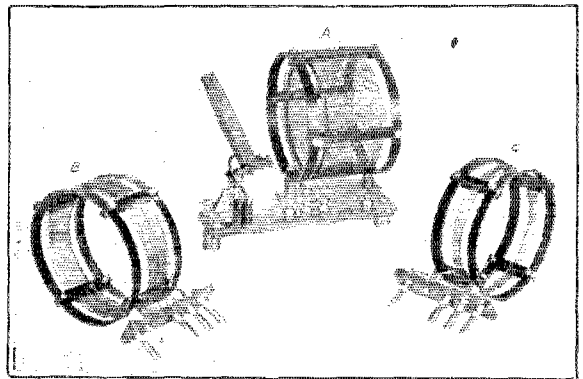

Fig. 2. The three "plug-in" coils and base holding adjustable primary. Note the small feedback coils inside of the main inductances. The coils here shown are made by Aero Products, Chicago.

and leak, are connected across the main inductance. Closely coupled to the grid coil is the plate feedback inductance, B-P. This is located at the filament end of the coil and is connected to the plate at one end and to the filament circuit thru the 250 picofarad variable capacitor, which acts as a regeneration control. This constitutes the radio-frequency portion of the

*Consulting Radio Engineer, Experimenters' Section, A.R.R.L., and 9ZA, 5723 Winthrop Ave., Cleveland.

circuit. However, it is necessary to provide a DC path for the plate current through the B battery and it is therefore necessary to feed the output circuit (audio transformer or phones) through the radio-frequency choke coil to some point of the plate circuit. It is more desirable to connect the high potential end of the choke to the point shown rather than directly to the plate since the choke coil is acting merely as a very small capacity (equal to its dynamic distributed capacity when operating below its fundamental wavelength), and if connected directly to the plate it would have a greater effect on the operation of the R.F. circuit. The audio-frequency end of the circuit is essentially standard. Note the dotted grid return and grounded filament circuit. This will be explained in greater detail later.

The Tuned Circuit

The portion of your receiver which requires the most consideration is, of course, the grid circuit. The constants of this circuit determine the wave-band covered and therefore knowledge of the wave-band to be covered is the first requirement. It seemed desirable to include the three most popular bands, twenty, forty, and eighty meters, as well as the band lying between ninety and one-hundred-and-twenty-five meters. This means allowing enough overlap for safety's sake, that the range must be from about 17 to 130 meters. Now it is entirely possible to design a single coil, to be used with a given tuning condenser, which would operate over this entire range but the thing would be so critical and the three important bands would be so crowded (each covering only about six or eight dial divisions) that the receiver would be worthless from an operating standpoint. In addition to this, the L/C ratio would be very different at the upper and lower ends of the dial and the set would be inefficient on the lower frequencies (longer waves). It was therefore decided to use "plug-in" coils, one for each wave-band, and with sufficient overlap on either side so they would be continuous and cover the entire spectrum. The spectrum being thus divided into three sections, it was found that a variable capacity whose maximum was about 140 picofarads¹ and with an average low minimum, was necessary to cover and allow the required overlap. In order to make the tuning sensitivity equally critical all over the dial, the straight-frequency-line plate was chosen, as shown in

the photographs. Naturally, a condenser of rugged mechanical strength, and with electrical losses as low as possible, consistent with commercial construction, was decided upon.

The grid (secondary) coils themselves (Fig. 2) are wound with No. 18 bare copper wire, spaced its diameter. An extremely heavy size of wire was deliberately ignored, because of the excessive losses incurred when such a coil must be put into a set where there is not enough room for large spacing and large turns. It should be remembered that there is a best size of wire for each frequency and geometrical construction of coil. (See recent *QST* articles). The coils are all three inches in diameter, coil A having 19 turns, coil B, 8 turns and coil C, 3 turns. The coil forms are of rather unique construction and are the result of considerable design work, done to obtain minimum of solid dielectric with a given mechanical strength. They are made skeleton fashion, of two insulating rings spaced with four bars, upon which the wire is wound and then clamped with four more bars bolted directly over the first. This forms a very rigid arrangement and still does not increase the losses nearly as much as a solid tube or self-supporting coil (Lorenz fashion) would.

The plate coils are made of slightly smaller diameter and wound with a small size of cotton covered wire and slipped inside the main inductance and glued in place at the filament end. We are not concerned with the losses in the plate circuit

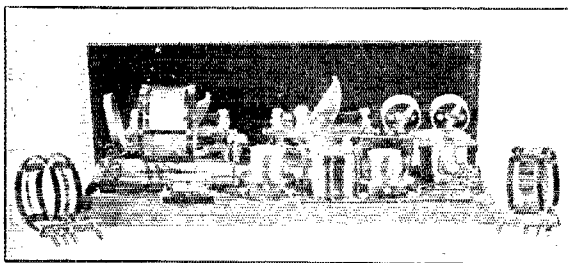

Fig. 3. Rear view of the receiver. Note plug-in grid leak and condenser and cushioned detector socket.

and therefore it is desirable to use a fine wire so that the capacity to the grid coil will be small. Coil A has 6 turns, coil B, 4 turns and coil C, 2 turns. The polarity of the windings of course must be correct so that the feedback is in the right direction.

The plug-in mounting and base arrangement are purely mechanical in nature and can be easily understood from the photographs. The single isolated plug at one end is the grid terminal, so placed that its

1. The picofarad is the same as the micromicrofarad.—Tech. Ed.

capacity to the others, and therefore the losses through the dielectric material of the base, are at a minimum. The increases in losses due to the plug-in arrangement have been found to be only about one-percent at the worst condition. This is practically negligible.

Now, having the grid and plate coils designed, the next important detail is the means of coupling the energy collector, or antenna, to the receiver. There are two ways in which this may be done, either by magnetic or electrostatic coupling. The former, is of course, the familiar primary

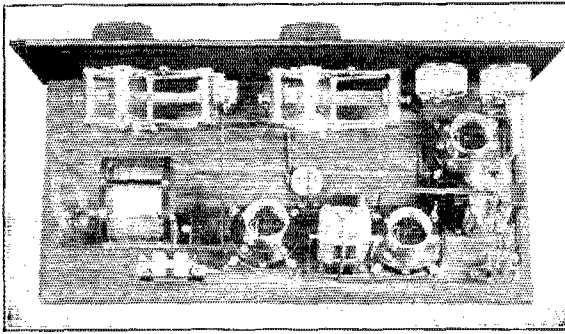

Fig. 4. Top view of receiver. The small desk in the center of the set is a miniature honeycomb coil used as the R.F. choke.

coil, and the latter is usually done by connecting a very small fixed capacity between the antenna and grid or plate of the tube. A rather exhaustive study of both of these methods was carried out in order that the best arrangement might be arrived at, and the final conclusion was in favor of the inductive coupling. This was for two reasons, and is really unfortunate, for the capacity coupled scheme is the simplest and cheapest in construction. The first draw-back to capacity coupling was the fact that no matter how small the condenser was, it detuned the circuit and made tuning, with antenna on and off, different. The selectivity, through high-wave, local broadcasting stations was not as good and a great deal of extraneous noises, such as A.C. hum, "L" trains, street lights, etc., were brought in much louder due to the necessity of grounding the filament circuit in order to get a good transfer of energy. These statements should not be construed to mean that the system is worthless; many amateurs are obtaining good results by its use, but it is *not* the best and most flexible. The one point in its favor is that antenna harmonics do not seem to affect the regeneration as much as with inductive coupling.

The primary coil is wound of ten turns of No. 24 D.C.C. wire and mounted on the plug-in base at the filament end of the

grid coil. This can be seen clearly in the photographs. It can be adjusted at an angle which gives the correct degree of coupling for the particular antenna used. Inasmuch as a lesser degree of coupling is desirable at the higher frequencies, the coils are mounted so that the smaller sizes are automatically placed farther away from the primary as they are plugged in, thereby making it practically unnecessary to change the primary coil position when changing coils. The primary is sufficiently loosely coupled so that its effect upon the calibration of the receiver is negligible.

The frequency bands covered by the three coils are shown in the three curves, Fig. 5, for coils A, B, and C. These curves are fairly accurate and can be used with the commercial product provided they are used under the same conditions as specified. The type of detector tube (electrode capacity) and the capacity of the grid condenser will affect the calibration slightly at the high frequency end of each scale. This change is not serious. Note that the most important wavebands, 20, 40 and 80 meters, are placed in about the center of the tuning range rather than at the lower end. This was deliberately done so that these bands might fall

in the most *efficient* portion of the curve. For further explanation of this theory, see the article, "Rating Circuit Resistance" by G. H. Browning, page 42, December, 1925, *QST*.

The completed receiver is shown in the photographs, Figs. 3 and 4. As most transmitting amateurs have the transmitter on the right, key and changeover switch in the center and receiver on the left, the set is built so that the antenna enters from the right, thus making the shortest leads. This is optional, of course, and the receiver can be assembled in either fashion. Two stages of audio are used, primarily to allow loud-speaker reception of foreign amateurs and broadcast stations, although this too, is optional to the builder.

The feedback control condenser may be of any shape of plate, either S.F.L., S.W.L. or S.C.L., so long as its maximum capacity is about 200 to 250 picofarads. Note the sponge-rubber cushioned socket for the detector tube. This is entirely home-made, as a suitable socket is not available on the market. It consists of a standard socket glued to a piece of red rubber bath-sponge cut to fit the socket and about one-half inch thick, which is in turn glued to the base-board. Four flexible, coiled leads are run from the base-board and the panel can be tapped vigorously without the slightest

microphonic noise in the phones. Some S/W receivers are so sensitive to these noises that the tuning dials cannot be turned without an incessant ringing sound.

The tubes recommended for use are standard UX201a's or 199's. The former are most desirable but either may be used to good effect.

A soft tube that will oscillate on the short waves, (if it can be found, and its hissing is not objectionable) may sometimes make a very sensitive detector for weak signals. The writer has used such a tube and obtained much louder signals from foreign stations, but they are usually critical and unreliable. Whatever type of tube is used, a good deal of time and patience must be spent in obtaining the best value of grid-condenser, grid-leak and grid return. In order to make such adjustment feasible, the condenser and leak

mounting are of the plug-in type so the different values may be tried. The smallest capacity possible on the highest resistance leak should be used, provided howling can be avoided. The writer has used 20 picofarads and 12 megohms to grid advantage with an ordinary 201A tube, but such values usually cause the tube to snap into oscillation with a long-drawn howl and are therefore difficult to handle. The correct adjustment is one which allows the tube to slide into oscillation with a soft "swish" not a "click," and still betrays a slight tendency to roar or howl. While these adjustments are being made, the grid-return should be varied from positive to negative "A" battery, in order to get the best condition. You will usually send up with a positive grid return, about 100 to 200 picofarad grid condenser and 7 to 10 megohm leak, although much depends upon the characteristics of the detector tube in use. A good deal of patience and juggling will be rewarded by much peppier signals than are usual from a short-wave receiver.

While these adjustments are being made, the various coils should be tried to insure that they will oscillate over the entire band. This should be done with the antenna disconnected and primary coil very

2. It is my experience that most "tube noises" are manufactured by the grid leak. In CW reception this is especially true and one must test dozens and scores of leaks to get one satisfactory 7 to 10-megohm leak. Those of lower resistance are better but they do not give the best sensitivity for C. W. reception. So far I have found but one make of grid leaks which is always quiet—alho this make is very carelessly rated and a "10 megohm" leak is just as likely to be an actual 7-megohm affair.—Tech. Ed.

loosely coupled. After this condition is obtained, the antenna and ground may be connected and the dials swept over the scale with the primary tightly coupled. Usually one or more "dead spots" will be encountered where the receiver cannot be made to oscillate. These are probably due to antenna harmonics and can be eliminated by either loosening the antenna coupling, or putting a load coil or series condenser in the antenna circuit to shift its period. Should this not clear up all the trouble the R.F. choke coil should be looked to. This coil is in circuit to prevent the distributed capacity of the audio transformer primary or phones from short circuiting the R.F. around the oscillation control condenser, and also to keep all R.F. out of the audio circuit, where it may cause howling. Its distributed capacity should

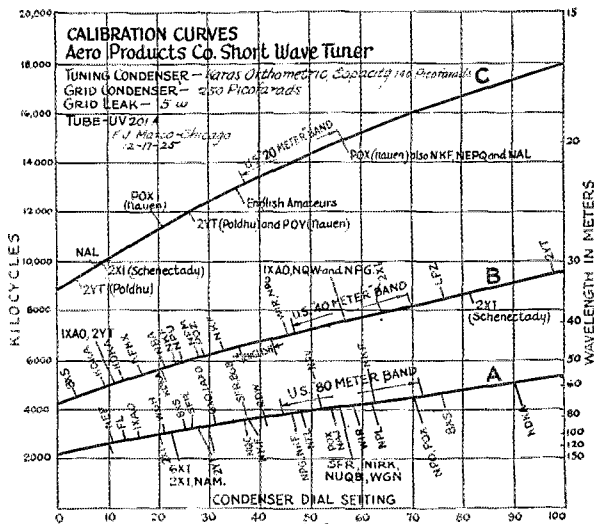

Fig. 5 Calibration curves of the set shown. The stations marked on the chart are shown for example only. Their waves may have been changed by the time this is printed. If they are to be used for receiver calibration the present wavelength should be gotten from QST or the Radio Service Bulletin.

The foreign stations are located as follows, POX, Nauen, Germany; SFR, 8GB and FI, Paris, France; RDW, Moscow, Russia; 2YT, Poldhu, England, LPZ Monte Grande, Buenos Aires, Argentina.

Warning! The curves shown are correct only for the particular condenser used and do not apply to any other, even if it is of SFL type.

be very low and it may be conveniently made so by winding about 200 turns of very fine D.S.C. wire (about No. 36 or No. 40) in either Lorenz fashion or on a one inch tube. The small honeycomb coils used in super-heterodyne intermediate-frequency transformers are usually O. K. Sometimes the harmonics of this choke will lie in the band somewhere and cause a dead spot to

appear which can be shifted by slightly changing the constants of the coil.

The fundamental diagram, Fig. 1, shows the filament grounded in a dotted line. This is entirely optional and may be best left off if excessive "body-capacity" is not encountered. Sometimes grounding the filament will bring in a lot of extraneous noises such as were previously mentioned. The detector tube and audio tubes are best run off separate rheostats as the detector usually functions best at a somewhat lower voltage than the audio. A "C" battery is not necessary on the audio if the grid returns are run to the negative A battery lead, (below the rheostat), and if not more than 90 volts are used.

A good slow-motion dial is an absolute necessity on the main tuning control as at the higher frequencies tuning is usually difficult. This should always be preferably of the friction type rather than geared, (with "backlash") as clashing metallic bodies in close proximity to the receiver cause a good deal of electrical noise at the higher frequencies due to changing capacity effects. Vernier control of regeneration is unnecessary if the receiver is to be used purely for C.W. reception. However, if short-wave broadcasting is to be received, a vernier dial, here too, is of advantage.

The regeneration control has only a very slight effect on the tuning and is sufficiently constant with frequency so that it may be set, for C.W. reception, at an optimum point and not touched as the tuning dial is changed as much as 40 or 50 divisions. A swinging signal may be followed by rotating the regeneration control about 20 divisions, (rather than the grid-tuning control), and a slight detuning is therefore an advantage in this case. The change in logging is nil.

In view of the fact that almost all short-wave enthusiasts in any reasonable location on practically any receiver are able to tune in countless foreign signals every night in the year, it is rather difficult to cite any outstanding superlative claims for this system. Its main advantages lie in reliability, ease control, sensitivity and constancy of calibration and a general adaptation for the usual foreign relay work. However, in deference to custom one can say that fourteen different countries have been received in a single evening and voice from several European and Australasian amateur and experimental stations have been put on the loud-speaker any number of times. The first, second and third har-

monics of foreign high-powered short-wave stations can be tuned-in by simply plugging-in any of the three coils and resetting. But you can all do that!

The New DeForest Tube

THE type H tube was designed especially for short wave work. The two filament leads coming out at opposite sides of the tube and the plate and grid leads at opposite ends result in a tube whose internal capacity is relatively low. For very short wave work construction of this type is desirable since the total capacity in the circuit will not necessarily lie mainly in the tube itself. The filament takes 10 volts at 2.35 ampere, the filament being an uncoated tungsten wire. The grid and plate are molybdenum, hence the tube can be operated in such fashion that the plate becomes quite hot before there will be any damage to the tube. Under normal conditions the plate can be operated at a dull red for quite a length of time. Plate voltages between 1000 and 3000 can be used with plate currents from 40 to 50 milliamperes with safe-

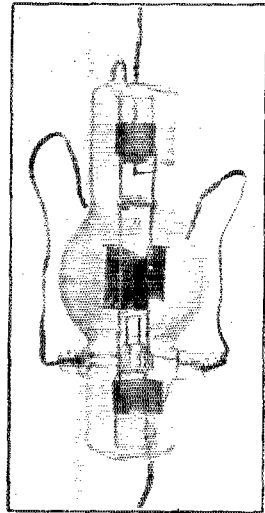

ty. The normal input rating is 150 watts, although for short periods this normal input value can be exceeded without permanent damage to the tube. For the $\frac{3}{4}$ and 5-meter bands a tube of this type should be a great advantage. For best efficiency the tube should be operated with a grid leak considerably higher than is normally used, something in the vicinity of 60,000 ohms being desirable.

—J. M. C.

J. I have often wondered why 4 amateurs out of 5 tolerate tuners in which every adjustment results in "gritty" noises. If one doesn't care for the frictional dials there is always the cheap and effective arrangement of a small and large pulley with a fish line belt.—Tech. Ed.

Battery Substitutes

By Robert S. Kruse, Technical Editor

THE American dry "B" battery has been developed to a high state of perfection. To displace the dry battery from the plate circuit of either a receiver or a low power transmitter indicates that there is available something which has an advantage in one way or another. Before beginning the following discussion of battery substitutes and aids it is interesting to see what possible advantages a battery substitute can have.

Roughly one can say that a battery substitute, to excuse its existence, must have advantages under one of the following headings.

- A. Economy.
- B. Convenience.
- C. Superior Performance.

It happens that those three headings make a very nice outline for a discussion of the subject.

Economy

I have not yet been entirely convinced of the economy of battery substitutes, for small and medium receiving sets. Even for a small set one can only consider the best of the substitutes because the performance of the poorer ones is so bad as

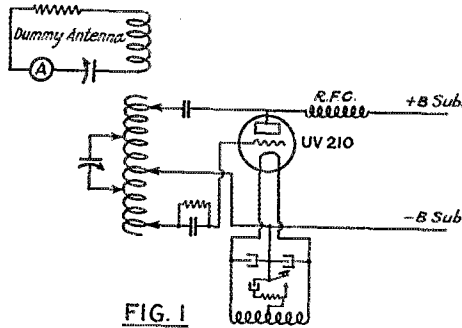

FIG. 1

THE TEST TRANSMITTER CIRCUIT.

The "clickless" keying system is the suggestion of Mr. Burton Synott of Station 2BBX.

to place them out of consideration. Now the price of the better substitutes is rather high and their probable performance over an extended period of years is entirely uncertain. For instance, one does not know what the probabilities are of difficulties in the substitute due to lightning disturbances during the next summer and the summers following. One also does not know in what way receiving sets will change and therefore cannot be certain to what extent the substitute will become ob-

solete before it is worn out. Therefore the owner of a small or medium set (four tubes or less) can hardly sell himself the battery substitute on the ground of economy, even if he is convinced that he will get five years of continuous use from it.

With the owner of a large receiving set or a transmitting set the matter is different. The initial investment in batteries for such sets is somewhat larger and in addition to this the life of the batteries is very much shorter; especially if some of the

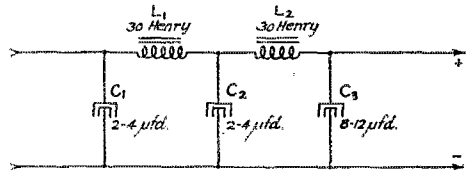

FIG 2

new tubes are used in the last audio frequency stage. It takes a much shorter period of years for the battery substitute to pay for itself, even when the other advantages of battery substitutes are not considered.

In any case of course one may be willing to purchase a somewhat better device. It then remains for every set owner to decide for himself whether the battery substitute is actually better for his purposes. To help him in that decision the following discussion is presented. It is based on 6 months painstaking comparison of different battery substitutes with a standard consisting of Burgess dry cells for the plate and a Willard storage battery for the filament circuit.

Convenience

Before the testing had gotten very far it became apparent that the gain in convenience varied a good deal, depending upon the design of the battery substitute, the design of the receiver, and the way of installing the substitute. In the case of the low power transmitter these things did not enter in.

Most receivers now are being built with the thought that there shall be one switch (that is to say the filament switch) which shall turn the set off and on. This arrangement leaves the battery substitute running and makes it a practical certainty that it will run for many hours when it is not in use. The manufacturer of the set cannot of course tell whether his set is going to be used with batteries or with a battery substitute and he dislikes to put

in an unnecessarily complicated switching scheme. To meet which situation several devices have been placed on the market which combine the A battery and the B battery in a convenient form. One of our photographs shows the device. The device shown appears at first sight to be only a filament battery with a charger. It goes somewhat beyond this however. The charger is one of the new trickle Tungars. The trickle charging idea in itself is of course not new. For some time there has been on the market a device made by the Fansteel Products Company of North Chicago in which an electrolytic charger is left constantly connected to the battery, even while one is receiving. With the usual single tube Tungar this does not appear to be possible, hence the Philco device has been equipped with a compound switch which can be seen at the left front of the box. When this switch is thrown to the upward position the filament battery is connected to the set. When it is thrown to the downward position the battery is disconnected from the set and automatically connected to the Tungar, which in turn is connected to the 110 volt

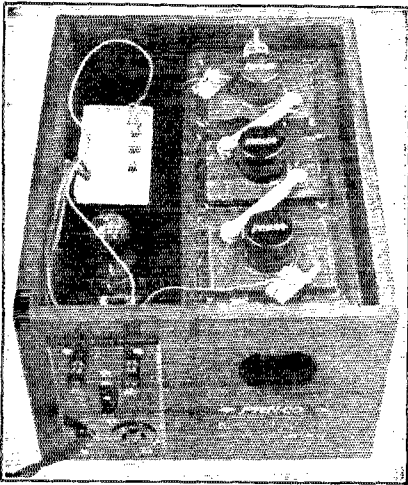

THE "PHILCO SOCKET POWER."

Battery at the right with peep hole to observe "gravity beads." At the left from front to back, master control switch, Tungar bulb and Tungar transformer.

line, so that charging is going on whenever the set is not in operation. In addition this same switch controls the plug receptacle from which the B battery substitute is supplied. Thus a single switch turns the whole thing off and on. If a battery substitute is not used this receptacle can be ignored.

There is shown also a photograph of the "Exide" version of the A battery with the

trickle charger. This is simply to illustrate the different possible constructions of such a device. Both the Philco and the Exide devices are made in four volt and six volt sizes.

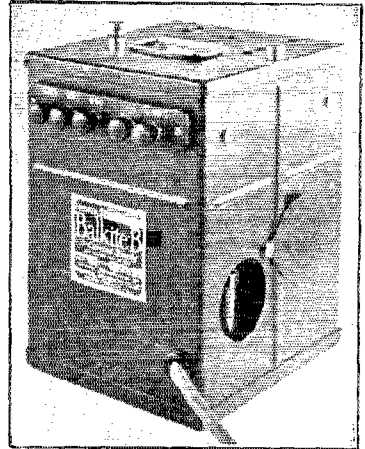

EXTERNAL VIEW OF FANSTEEL TANTALUM
Note primary fuse inside of window.

All of this is a departure from the main subject and was introduced simply to show that the use of the battery substitute can be made convenient.

Performance

Of course neither economy nor convenience are worth considering unless one can get worthwhile performance from a device. To find out what performance could be expected the tests previously mentioned were made. A great deal of time was wasted at the beginning by attempting to find out something about the battery substitutes by measuring the current output with milliammeter and voltmeter. There were two reasons why this was a mistake. In the first place any ordinary voltmeter is in itself enough of a load to pull down the voltage of many battery substitutes. These are a few exceptions to that rule, but not many. In the second place, if one has a lot of curves showing output performance, what of it? One still does not know whether the output is of a satisfactory character, whether it is free from radio frequency disturbances, and in general one has been investigating the wrong thing. Therefore this idea was dropped entirely and an investigation begun to find out what the substitutes would do in actual performance in both receivers and transmitters.

The Test Sets

The test sets were as follows:

A. A regenerative detector with two

stages of high-grade transformer coupled radio amplification.

B. A crystal detector with a resistance coupled audio amplifier.

C. A General Radio superheterodyne without audio amplification.

D. A Mu-Rad type A receiver with two stages of tuned radio frequency amplifica-

tion because many of the substitutes were not adapted to all of the receivers or else had some obvious characteristic which could be determined without much testing. It is interesting to note, by the way, that the tests were *not* made at an especially favorable time. The devices are constantly under development and of the 32 tested only 19 are at this moment on the market. These 19 are unquestionably the best of the assortment.

Very little time was spent on continuous wave reception because this is ordinarily accomplished with a detector and one stage of audio amplification which is a receiver so simple as not to justify the expense of a battery substitute. The tests were therefore confined mainly to broadcast reception. In order to insure that defects of filtration would be noticed, the reception was confined to stations known to transmit material with good audio quality. These stations were WJAZ, WEAJ, WJZ, WTIC, WPG and WGY when the latter was not spoiled by audio frequency fading which is common at Hartford.

During all tests at least two people checked on the results so as to remove as

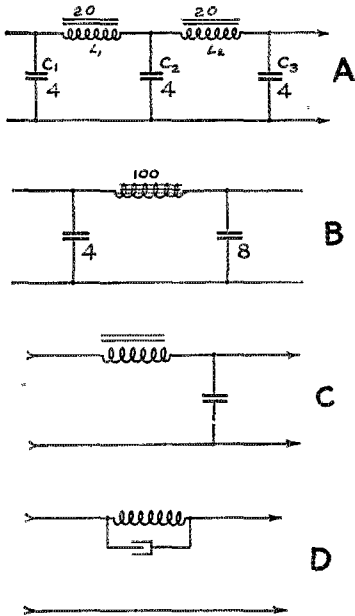

FIG. 3
TYPICAL FILTER DIAGRAMS.

Where constants are shown they are the one used in successful filters.

tion, a detector and two stages of high-grade transformer coupled audio amplification.

E. A Zenith receiver using two stages of uncompensated radio frequency amplification (kept near point of oscillation by rotatable portions of the transformer primaries), a detector and three stages of resistance coupled audio amplification. The original amplifier of this set was not used. The change was made because it was desired to use one set with resistance audio *after* a radio frequency amplifier.

It will be noticed that the receivers were chosen with a view to covering the types ordinarily in use.

Method of Testing

There is no purpose in detailing the tests. About 300 hours were spent on the comparisons themselves, plus a considerable amount of time spent in preparation. This time is not as insufficient as might seem

far as possible the element of personal prejudice.

When a loud speaker was used it was the Crosley "Musicone" which was chosen because it is sensitive to residual ripples which have come through the filter.

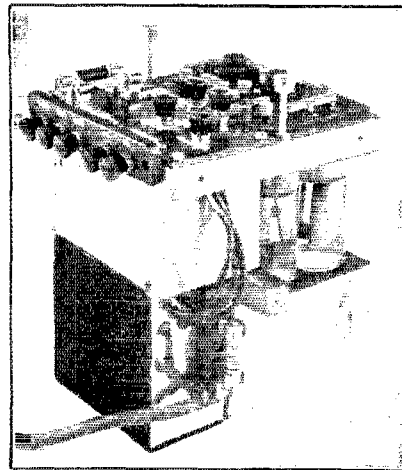

INTERIOR CONSTRUCTION OF FANSTEEL
SUBSTITUTE.

At left front is the supply transformer and the primary fuse. Just above it is the condenser box and above that the voltage control switch (high and low) and the resistance through which the drop is obtained to give the 20 and 80 volt output. At the back the six jar half-wave tantalum rectifier and below that the chokes. All units separately shielded and connected together inside the external steel case.

Transmitter Tests

A small transmitter (Fig. 1) was set up with a UV-210 tube and a dummy antenna circuit. Nothing was done with this excepting to check the tone quality and steadiness and to observe the possible output. In most

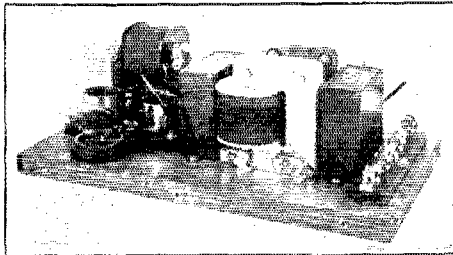

THE "APCO" SUBSTITUTE.

At the left supply transformer with sockets and control rheostat in front of it. Next, can containing first condenser of filter. Next filter choke (one in each side of the line), next can containing terminal condensers and resistance by-pass condensers. To the right strip carrying resistances through which lower voltages are obtained.

The use of a choke in each side of the filter is unusual and in this case results in particularly good filtration.

cases the supply to this tube was too limited because of the resistance of the filter circuit. When a filter with lower resistance chokes was substituted a very nice little transmitter resulted. Because of the comparative large output available the Radio Corporation, Dubilier, Apso and Acme devices were particularly suitable among those tested. However, not all of the devices available were tried on this test as over two-thirds of them had been returned before the idea of using such a device for transmitting supply had occurred.

Regenerative Sets

It was soon found that the most critical test of the goodness of filtering was to try



**FIG. 4
METHOD OF OBTAINING C VOLTAGE.**

the device on the regenerative detector with two stages of audio amplification. Many of the devices that appeared perfectly quiet when used in the Mu-Rad or Zenith sets, or in the superheterodyne were quite hopeless when the regenerative detector was operated in a normal fashion. This is not a very severe indictment because the larger sets, where one is likely to employ battery substitutes, do not usually operate on the edge of oscillation.

Radio Amplifier Supply

The last two sets were (Mu-Rad + Zenith) so connected that it was possible to supply the radio frequency amplifier, the detector, and the audio frequency amplifier from different sources. It was a great surprise to find that the radio frequency amplifier was apparently most sensitive as to the remaining hum in the substitute. No positive conclusion was obtained as to the reason for this. In some cases it appeared to be induction, in others mechanical vibration from the substitute. In these cases the thing could be cured by removing the substitute from the set and putting it several yards away. In other cases something appeared to be going on in the way of superimposing modulation upon the incoming signal. The best of the substitutes did not make this trouble.

Detector Supply

Next after the regenerative detector and the radio amplifier the greatest "touchi-

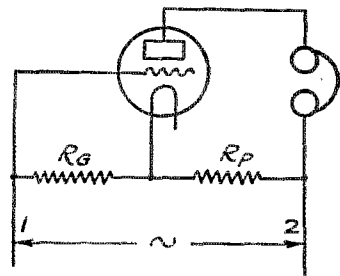

FIG. 5

DR. J. M. MILLER'S METHOD OF MEASURING AMPLIFICATION CONSTANT.

The amplification constant is found by lighting the filament of the tube, connecting an alternating voltage to the points 1 and 2, and then adjusting the resistances R_g and R_p until no sound is heard in the phone. The amplification constant of the tube is now equal to R_p divided by R_g .

ness" appeared to be on the part of the detector tube, in the last two sets listed.

Audio Amplifier Supply

The audio amplifier appears to be rather insensitive as to hum in its plate supply. It was possible to supply this end of the set satisfactorily from devices which were quite hopeless when used to supply the entire set. This is particularly true of the last stage of audio amplification. I cannot however agree with the general impression that a faint remaining hum is all right. On the contrary we seemed to find definite injury to the quality of the received signal whenever *any hum at all* was noticeable. Of course that isn't very serious because the

average grade of broadcast material is so wretched that one can never recognize the difference. For the matter of that in the early part of the evening (on the East Coast) one usually cannot tell whether an out-of-town station is good, bad or indifferent because it is being so unmercifully

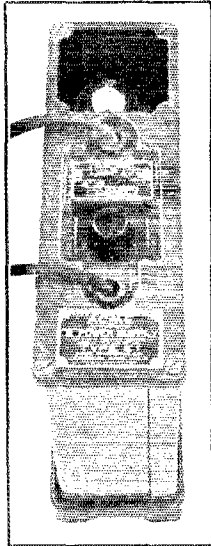

THE ACME APPARATUS COMPANY'S VERSION OF THE "RAYTHEON" BATTERY SUBSTITUTE.

At the front two conductor input cord from 110 volt line, next compression rheostat to provide variable detector voltage, next voltage control switch with two positions, next three conductor output cord and lastly Raytheon tube in its cell. All units but the tube are separately shielded inside of the cast and pressed metal case.

hashed by the 400 unnecessary broadcasting stations. For that reason all of these tests were made after 10:30 P. M., Eastern Standard Time.

Rectifiers

All of the battery substitutes which were tested consist of a rectifier and a filter system. These rectifiers are of three types, that is to say, electrolytic, Kenotron or gaseous rectifier tubes. Leaving out the ones that have now gone off the market, the division of the ones tested was as follows:

- Gaseous tubes (such as the Epom, Raytheon, etc.) Four.
- Electrolytic Five.
- Kenotron Six.
- Kenotron plus gas tube One.
- Completely sealed but probably electrolytic One.

A brief discussion of these rectifiers is enough for the moment. The gas tube has been discussed sufficiently in this magazine.

One has only to refer to page 38 of the November issue and to page 41 of the January issue.

The electrolytic rectifiers tested were of two types. One uses tantalum as one electrode and operates in the ordinary sulphuric acid solution used in lead storage batteries. These rectifiers are formed at all times and therefore can be thrown on the line without protection. The other rectifiers use aluminum as one of the electrodes (there is a suspicion that one of them may be using magnesium) in solutions that appear to consist mainly of citric acid. These rectifiers do not remain formed permanently and hence a protective resistance must be used to prevent damage when they are first put on the line after a period of rest. This gives less perfect regulation on the output unless the protective resistance is reduced to a low value.

The tantalum rectifier therefore regulates better and incidentally also requires no attention except the addition of water, there being no chemical action on the electrodes themselves. The other rectifiers wear out gradually but have the advantage of a solu-

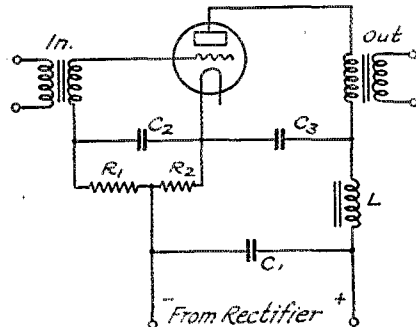

FIG. 6
CIRCUIT OF THE WESTERN ELECTRIC 6025B AMPLIFIER.

The wiring scheme is such that an alternating current balance is obtained exactly as in the Miller method of measuring amplification constant. The only difference is that in place of pure resistance the system employs inductances which must also be balanced by corresponding inductances.

The diagram shows the filter and amplifier only. Rectification is accomplished by another tube of the same type contained in the apparatus and operated by the same transformer. In the actual apparatus the filament returns to the center tap of the filament transformer secondary.

tion which is harmless if it is ever accidentally spilled.

Kenotrons

It will be remembered that all of the earlier battery substitutes used receiving tubes as rectifiers, simply connecting the grid and the plate together so that they became Kenotrons. If a single receiving tube

is used to supply several receiving tubes then the rectifying tube will obviously be overloaded and its filament life will be so short that the operation of the substitute becomes exceedingly expensive. As an extreme case where one of these devices was used to operate a six tube receiver the life of the UV201A rectifying tube was usually in the neighborhood of 15 hours. If such a set is used to supply only a few tubes, or if two rectifying tubes are used (preferably one on each side of the cycle), the scheme becomes practical. The larger the rectifying tube, the more practical the entire proposition becomes. Such tubes as the UX-112 and the UX-120 are a step in the right direction. Still better is the UX210 which can be expected to give a good account of itself, provided the substitute has the necessary filament voltage available. Recently special tubes have been designed for exactly this purpose, notably the UX-213 which is in itself a full wave rectifier, having two filaments and one plate in the same bulb.

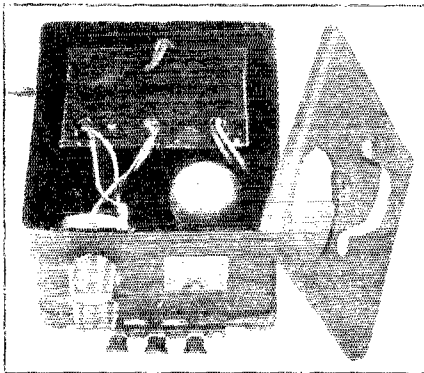

THE RHAMSTINE BATTERY SUBSTITUTE.

Employing half-wave rectification with a receiving tube. The transformer and the filter system are contained in the can at the back. The upper rheostat controls the filament brilliancy and the lower one controls the voltage on the detector output terminal.

Concerning Filtration

Of the substitutes tested only a very few had entirely satisfactory filters. The reason is obvious. Condensers and chokes cost money. Perhaps that statement is not entirely fair because there is sometimes a remarkable difference between the theoretical and the practical results gotten from a filter. Thus for instance the filter shown in Figure 2 is usually very satisfactory. However there are certain conditions under which surprising noises come through it. Usually when this is the case there is nothing definitely wrong about the installation, either there is some manner of radio frequency disturbance on the 110-volt line

or else the rectifier is not operating properly. One should therefore not be too quick to condemn the manufacturer. Putting in a new rectifier unit and making sure of the condition of the 110-volt line are things first to be attended to. If all these things are in order and the filter itself has not been

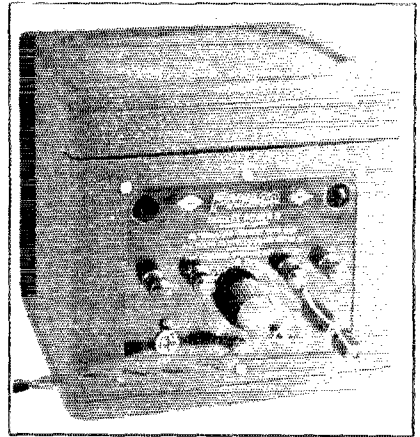

EXTERNAL VIEW OF "PHILCO SOCKET POWER B."

Lower right jack and plug voltage control. To the left of that compression rheostat controlling detector voltage and to the left of that off and on switch not used if connected to master switch on A battery.

The "Blank" terminal is one end of a condenser, the other end of which is permanently connected to one side of the 110 volt line. When there is a troublesome hum it can frequently be cured by connecting the "Blank" to the negative B post, either with or without reversing the connections to the 110 volt line by rotating the attachment plug tap.

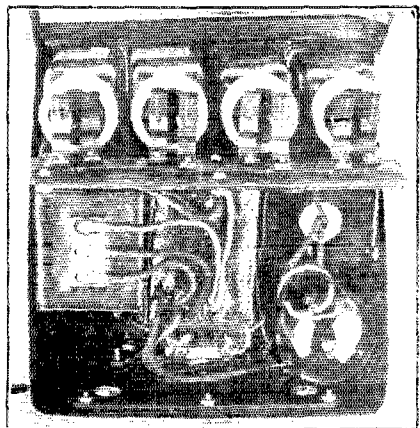

INTERNAL VIEW OF THE "PHILCO SOCKET POWER B" SEEN FROM ABOVE.

At the back four rectifier jars known as "Philco-trons." These jars are replaced as units when exhausted, although their life is very long. To the left tapper choke. At the center can containing condensers. At the right input transformer and protective lamp.

injured, then a construction such as shown in Figure 2 will usually perform very well indeed. An exception is the case of the regenerative set but that is stated in its

Going now to the other end of the filter and looking at it from the standpoint of the receiving set one discovers the following. The load of the receiving set is not a steady one. The current taken by the radio frequency tube varies at a radio frequency while that taken by the audio frequency tube varies at an audio frequency. If we are thinking of a 6 tube set (standard tubes) and are receiving strong signals with 130 volts on the last tube of the set it is entirely possible for the instantaneous demand upon the battery substitute to go as high as 35 milliamperes and as low as 5 milliamperes. The average

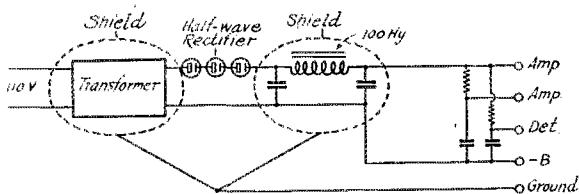

FIG. 7

DIAGRAM OF A HIGH-GRADE-ELECTROLYTIC SUBSTITUTE.

Note the exceedingly large inductance of the filter choke.

own paragraph to which the reader is referred.

Cheapening the Filter

A filter such as shown in Figure 2 is exceedingly expensive to make properly. To explain why it is not safe to cut it down a great deal one may follow a simple explanation of the action of the device which has been given by Mr. F. S. Dellenbaugh.¹ Professor Dellenbaugh stated to me that one could say approximately that the condenser C1 governed the regulation, the condenser C2 the goodness of filtering and the condenser C3, the goodness of audio frequency output from the set. It seems peculiar that one could so divide the func-

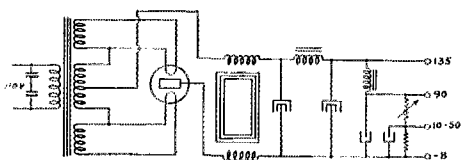
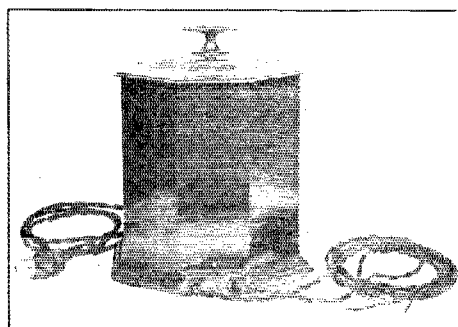

FIG. 8

CONNECTIONS OF A HIGH-GRADE KENOTRON SUBSTITUTE EMPLOYING FULL-WAVE RECTIFICATION IN A SINGLE TUBE.

tions of the three condensers but an evening spent in making check tests shows that the statement is accurate enough for practical purposes. This can be explained as follows. The choke L1 has (if the filter is any good) an inductance of at least 20 Henrys. The pulses of current from the rectifier can therefore not get through it very rapidly and must be stored for a fraction of a second in the condenser C1. Without getting too scientific about it, one can therefore say that the *immediate* good upon the rectifier is the condenser C1 and that the output of the rectifier will mainly depend upon the size of C1.



EXTERNAL VIEW OF THE WESTERN ELECTRIC 6025B AMPLIFIER.

value will of course be somewhat in between. Now these variations, the momentary demands, fall upon the final condenser C3 and not directly upon the rectifier. If the final condenser C3 is not large enough the instantaneous demands will not be met properly and therefore the output of the set will

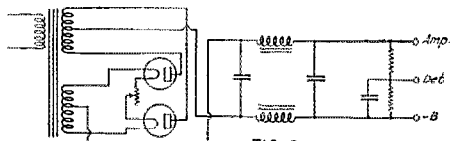

FIG. 9

DIAGRAM OF A SUBSTITUTE EMPLOYING RECEIVING TUBES FOR FULL WAVE RECTIFICATION.

suffer as to either quantity or quality, and generally both.

We now see that we can regard the last condenser as governing the quality of the receiver output, the first condenser as governing the regulation of the substitute and therefore the second condenser C2 quite logically falls back to a position where its only function is that of improving the goodness of the filtration above what would be obtained if only the other two condensers

1. Mass. Inst. of Technology, Cambridge, Mass., Author of most of QST's filter articles.

were used. Anyone doubtful of this explanation can check it up on his own account easily enough by building a filter and then cutting down the various condensers, one at a time.

faint that it can barely be heard with a loud speaker. I should say therefore that any battery substitute giving a hum which could be heard with a loud speaker (even the sensitive Crosley "Musicone") was definitely too bad and should not be used.

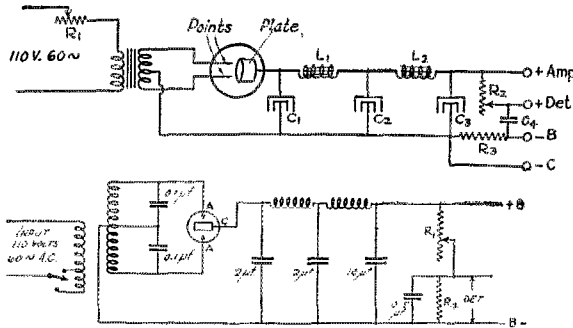

R_1 is a variable carbon resistance of 10,000 to 100,000 ohms
 R_2 is a fixed resistance of 10,000 ohms

FIGURE 10—CONNECTIONS OF TWO SUBSTITUTES EMPLOYING FULL WAVE RECTIFICATION IN A GASEOUS RECTIFIER TUBE.

A good many battery substitutes are made under the mistaken impression that a hum in the loud speaker does no harm provided that it is not heard when one is receiving broadcasting. I cannot agree with this at all. After spending rather more

Now it is not necessary to stick religiously to the filter of Figure 2. For instance the "Epom" substitute presented in our January issue uses the modification shown in Figure 3A. It is observed however that this device still uses a two section filter with a total of 12 microfrads of capacity present. One way of cheapening the filter is to leave out the center condenser C_2 whereby one gains a structure like that shown in Figure 3B. This operates pretty well if the total capacity is kept the same as it was for the structure of Figure 2A and if the inductance of the choke is made at least as large as that of the two chokes shown in Figure 2A. One substitute on

the market provides satisfactory filtration by using the constant shown on the diagram Figure 3B. A great many others have tried the same diagram but have skimped on the constant shown and are unsatisfactory in just about the degree to which they have skimped.

The diagrams of Figure 3C and 3D have been and are being used in some cheap battery substitute. Neither of these diagrams is satisfactory in any examples that I have met. Diagram C fails even when the inductance and condenser are very large. Diagram D is a tuned choke and fails as

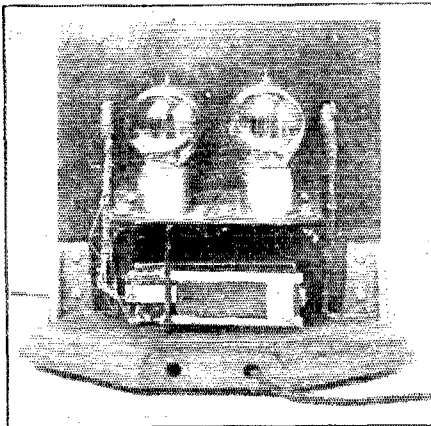

REAR VIEW OF THE WESTERN ELECTRIC 6025B AMPLIFIER AND CURRENT SUPPLY SET.

At the lower center is the transformer supplying both the filament and the plate circuit. To the right and immediately above are condensers of the filter system. At the extreme left is a choke.

than 300 hours in painstaking testing of the 32 substitutes with the five receivers previously mentioned I am firmly convinced that the quality of the audio frequency output is definitely damaged even when the hum on the plate supply is so

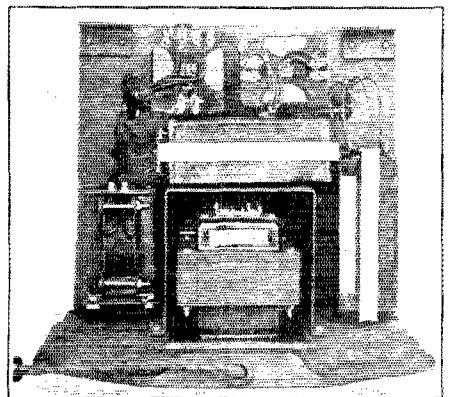

FRONT VIEW OF 6025B WESTERN ELECTRIC AMPLIFIER WITH SELF-CONTAINED CURRENT SUPPLY.

On the shelf are the rectifier and amplifier tube. Underneath the shelf are resistances and a condenser belonging to the filter system.

soon as the frequency of the power line changes a little bit. When the thing is in tune its performance is passable although not particularly brilliant and therefore it keeps attracting manufacturers who are trying to do the thing to cheaply.

C Battery Supply

Just as various B voltages can be obtained by I.R. drop through resistances so it is possible to obtain any desired C or grid

the plate current variations are not so bad that the plate current will ever drop below the value needed to take care of all of the audio modulation which is present.

A beautiful example of the use of this principle is the Western Electric amplifier, which is illustrated by photographs and by the diagrams of Fig. 5 and Fig. 6. This amplifier is intended to work the Western Electric conical loud speaker, either the 18 inch 540AW or the new 36 inch 548AW and 548CW. To handle the necessary energy a 5-watt tube (approximately) of Western Electric type 205D is used. Several hundred volts are provided for the plate circuit of the tube and the whole device takes 40 watts from the 110 volt line. Devices of the same general nature are made by other manufacturers.

One should observe one thing in particular, however. The business of balancing out the remaining ripple by a varying grid voltage as is done in this amplifier is possible *only* when one knows all about the amplifier tube that one is feeding. A device of this kind may or may not work perfectly, if it is applied to any audio amplifier that happens to come handy. The chances are that it will be better than if the circuit trick were not used, but after all, when one does not know just what the amplifier will be like it is best to make sure by making the filter

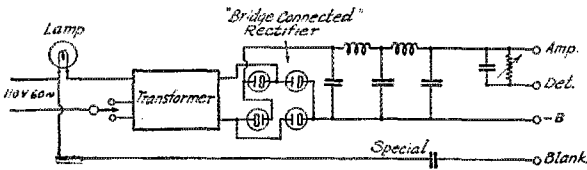
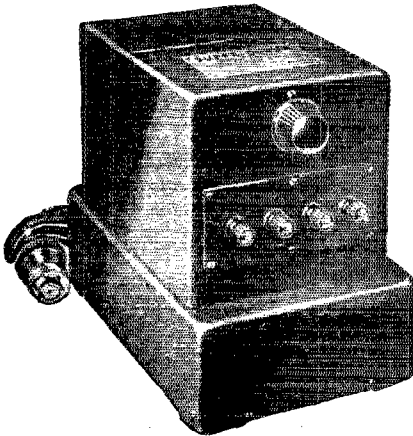

DIAGRAM OF AN ELECTROLYTIC SUBSTITUTE USING FULL-WAVE RECTIFICATION.

voltage in the same fashion. The general scheme is shown in Figure 4. The obvious advantage is that it does away with another battery. An even greater advantage of such a scheme is that if the filtering is not per-



DUBILIER "SUPER-DUCON."

A substitute employing full wave rectification in a double filament Kenotron.

The welded steel case is divided by steel partitions into four compartments. One of these contains the tube and the variable resistance for controlling the detector voltage. The remaining three contain packages insulated with paraffined fiber board. One of these packages contains the transformer, another one contains two chokes and the remaining one contains two more groups, a fix resistance and a group of condensers.

fect this system of connection will produce a grid voltage which "wabbles" in the proper fashion to tend to overcome the wobble in the plate circuit. If the constants of the circuit are chosen properly a remarkably poor filter may be used with excellent final results. One must be sure, of course, that



THE EXIDE A BATTERY WITH TICKLE CHARGER AND MASTER SWITCH. THERE IS ALSO A 6 VOLT TYPE.

as good as possible. Just how good that will be depends on how much money one wants to pay for it.

The sort of evidence here given is not final or conclusive. It may, however, represent more information than most users of

receiving sets and low power transmitters are able to get together on their own account. Clearly the battery substitute is still in a state of development and also, and equally clearly, there are already some good ones available.

Acknowledgment

For information used in this article and for the loan of the apparatus employed thanks are due to a considerable number of my personal friends and also to the following commercial organizations: The Electric Transportation Company (Hartford Agency of Philadelphia Storage Battery Company), The Fuller Battery Company (Hartford Agency for the Willard Battery); The C. F. Burgess Laboratories; The Chicago Radio Laboratory; The Zenith Radio Corporation; The Mu-Rad Radio Corporation; The Granie Corporation; The Zinke Company; The Acme Apparatus Company; The General Radio Company; J. Thomas Rhamstine; American Appliance Company; Apco Manufacturing Company; Fansteel Products Company; General Electric Company; Eastern Cycle Company (Hartford); Valley Electric Company, and the Dubilier Condenser & Radio Corporation.

Easier Tuning

It is desirable, with amateur receivers especially, to have the tuning and regeneration control devices fitted with vernier dials or geared verniers having a high ratio. Unfortunately when the ratio is much above 10 to 1 there is so much time

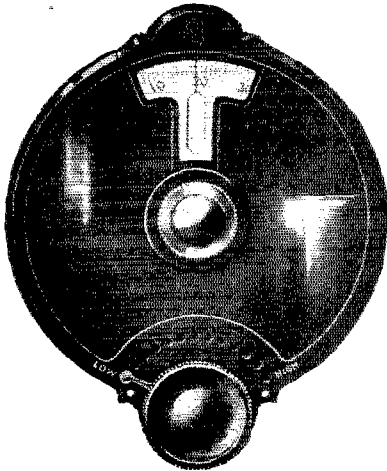

lost in running from one end of the scale to the other that such dials are rather impractical in ham receivers. What is needed is a dial having *two ratios* one of them a direct

1 to 1, or a vernier not greater than about 8 to 1, and the other a much higher ratio. We now have such a dial—two of them in fact.

The National type B has the well known Velvet Vernier movement built into a new style of direct mounting dial. The vernier ratio can be varied in gradual steps from 6 to 1 to a much higher ratio around 20 to 1 merely by moving a small lever fitted directly above the control knob. The dial can be fitted to any quarter inch shaft without any special rigging or mounting, it merely being necessary to loosen a set screw, slip the dial up close against the panel and tighten up the set screw. The scale is on a heavy celluloid circle mounted on a brass disc and enclosed in a mottled bakelite case. The dial is made by the National Company of Cambridge, Mass.

The Bell Vernier Dial also has two ratios. The vernier operates through three degrees of the dial scale after which it automatically steps into a direct 1 to 1 ratio and continues to operate at this ratio until the direction of rotation is reversed. While acting as a vernier the reduction is approximately 15 to 1. The dial is fitted to the

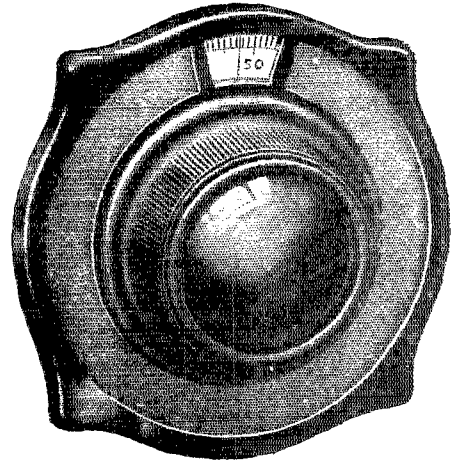

panel by means of two machine screws moulded in the bakelite housing, the screws being pushed through holes in the panel and held in place by two nuts. This dial is made by the Bell Manufacturing Company of Boston, Mass.

—J. M. C.

Strays

1KP had to take his counterpoise down because it was in the apple orchard and when the apples fell off the trees they were cut in half (or thereabouts) by the counterpoise.

Easy Money for Ham Tuner Designs

LOOKIT, Gang, somebody is actually offering real money for designs for short-wave C.W. receivers. This is our meat. It has seemed to the Editor that when hard cash is offered to the world for designs relating to short-wave radio, it is certainly of interest to this A.R.R.L. membership. If we know any thing about it, some of the prize money is going to be won by A.R.R.L. members. This thing looks to us like it was a made-to-order opportunity for telegraphing amateurs. Here is the story:

The magazine *Radio Broadcast* wants a short-wave receiver that it can recommend to its readers. It does not feel that it can recommend any receiver it has yet seen, chiefly because most such receivers radiate, which "R.B." frowns upon as an editorial policy. The editors of that magazine therefore have determined to hold a contest, having as its object the development of an improved non-radiating short-wave tuner, and to that end they offer three prizes, the first of \$250, the second of \$150, and a third of \$100.

Anyone interested in short-wave reception is eligible to compete, although no prize will be given to manufacturers mak-

Radio Broadcast is also to be permitted to use descriptive matter submitted by any contestant, as magazine material, at its regular rates.

The competing sets will be judged on a basis of points as follows:

Workmanship	15
Simplicity of handling. (Ease of calibration, freedom from hand capacity, independence of tuning and regeneration)	20
Low cost	10
Use of standard or easily constructed parts	5
Performance (Over-all amplification of signal, use in relaying, ability to use break-in, ability to cover foreign amateur bands)	25
Appearance	15
Method of avoiding radiation	10

Total 100

The contest closes March 1, so there is no time to lose. All correspondence and prize manuscripts should be addressed to Director of the Laboratory, "Radio Broadcast," Doubleday, Page & Co., Garden City, N. Y.

The Board of Judges consists of Prof. L. A. Hazeltine, Dr. A. Hoyt Taylor, G. C. Furness, A. H. Lynch, Dr. L. J. Dunn, E. H. Felix, Boyd Phelps and Zeh Bouck.

There's the story, fellows. Hop to it, now, and let's see some of our bunch take *R.B.'s* money away from them.

K. B. W.

Central Division Convention

(4th Annual Michigan State) at Kalamazoo, Mich., March 26-27, 1926

AHOY! Ahoy! there Michigan Hams and others. Look above for the dates of the forthcoming annual convention, the one you are always looking forward to. The events for the two days are in the hands of old timers and they are going to make it worthwhile to the delegates who attend. "Jimmie" Wilson is the General Chairman and he tells us the PARK AMERICAN HOTEL will be the headquarters for everything. Good rooms will be available at reasonable prices and a number of free rooms will be provided in the homes of Amateurs.

Convention fees will be five dollars (\$5.00) and will cover all meetings and the Banquet. A discount of 20% from the fee to all sending in cash with reservation on or before February 15th to Jas. A. Wilson, 911 Lay Blvd., Kalamazoo, Mich.

-A. A. H.

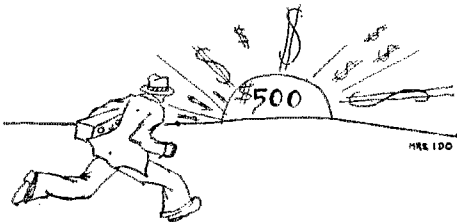

ing short-wave receivers or parts thereof. Each contestant must submit a complete description, photographs and hook-up of a short-wave receiver which does not radiate. The receiver should be adapted to the entire short-wave band from 35 to 150 meters; interchangeable coils are permissible. *Radio Broadcast* shall be permitted to request the most promising receivers sent to its office in order that actual tests may be run in determining the final award of prizes.

1—*R. B.* suggests consideration of such loose coupling that the oscillating tube can't radiate; the use of a stage of neutralized R. F. ahead of the oscillating detector, as a blocking tube, etc.

2—This is a little confusing, as *R. B.* speaks in another place of a receiver that preferably "will cover all of the amateur bands, but most certainly the so-called 40, 80, 150 meter bands." The so-called 150-meter band of course runs from 150 to 200, and there is nothing of particular interest between 150 and 150. To be on the safe side we therefore suggest that contesting sets should be capable of tuning up to 200 meters.

A Zero Weather Mast

SOMETIME ago Don C. Wallace of 9ZT and Boyd Phelps, who ran the previous 9ZT at the Courthouse in Minneapolis, decided to try the experiment of a very long receiving antenna at 9ZT. Another mast was needed in a hurry and the Minnesota winter weather had already gotten down to zero. That didn't stop these two. They hurriedly thought out a mast that could be erected quickly, got the material together and did the actual erecting of a reasonably solid 50-foot mast in fifty minutes. Maybe Wallace's size has got something to do with this because he dismantled it completely and took it apart in an hour and a half. However with a little more time almost any-

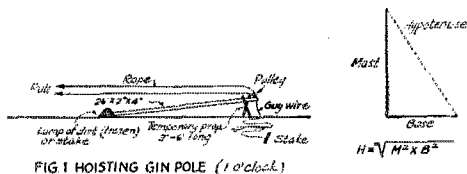

FIG 1 HOISTING GIN POLE (1 o'clock)

body can do the same thing provided he can get the material. That's a real difficulty up in this part of the world where we print QST, because we have never been able to get a lumberman to admit that there was such a thing as a "clear" 2 x 4 over 10 feet long.

The proceedings are pretty simple. A 26-foot 2 x 4 is laid out as shown in Figure 1 one end being propped anywhere from 3 to 6 feet up in the air and the base of the stick put against something solid. Three guy wires have previously been measured, cut and secured to the sticks. The length should be somewhere within a foot or so

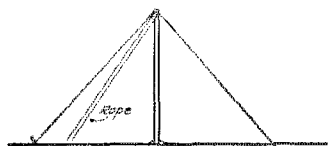

FIG 2 GIN POLE UP (1:10 PM)

of the correct value otherwise the mast is likely to do queer things after it has gotten almost upright. The little sketch down in the corner of Fig. 1 shows how to calculate the length of the wires. If you don't want to bother with the calculating make a drawing to scale and measure the wires off with a ruler.

Fig. 2 shows the gin pole up, the guy wires having been adjusted to make it stand vertical.

In Figure 3 the mast itself has been laid out. This consists of two 26 foot two by fours bolted together and provided with top guys and a hoisting rope of enough length to reach the ground when the whole thing is up. The rope at the top of the gin pole is fastened to the joint in the mast

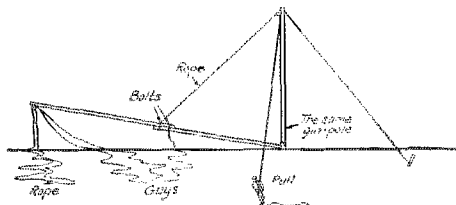

FIG 3 THE MAST GOING UP (1:30 PM)

and everything is ready for hoisting. No, not quite. Another 30- or 40-foot piece of wire must first be fastened to the center of the mast. In Figure 4 the thing is up and one only needs to take the extra wire from the center of the mast and walk around underneath the lower guys, keeping a good pull on the wire so as to bind the mast firmly to the gin pole.

That's all except to true the whole business up with the guy wires.

The 750-foot single wire receiving an-

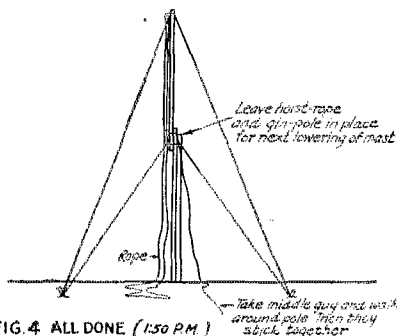

FIG 4 ALL DONE (1:50 PM)

tenna has given very excellent results. The location of 9ZT is cursed with a continual power leak of varying intensity and it was necessary to drag in a strong enough signal to overcome this. Of course it was an even bet whether the power noise would not go up at the same time. It did go up but not in the same proportion. Many stations in Europe, New Zealand and South Australia are copied regularly now whereas they could be heard only with the greatest difficulty before.

The 750-foot antenna, by the way, is supported on three masts standing in a row.

—R. S. K.

Filtering The Synchronous Rectifier

By Chauncy Hoover*

AT the time I began the experiments contained herein, it was the general opinion (and seems to be at the present time) that the output of a rotating synchronous rectifier could not and cannot be successfully filtered; that such a rectifier could always be recognized by its rattly tone. Believing that a filter system could be devised that would overcome the fault, I purchased an Advance Electric Co. "sync" and after numerous experiments reached the result sought after.

In the first attempt I applied a filter built as shown in Fig. 1 which I had formerly used on my kenotron rectifier. This had worked very well in connection with my transmitter of one or two UV203's and two large kenotrons, but when applied to the "sync" immediate fireworks resulted. I found that I was able to synchronize by shifting the brushes for sparkless commutation under load, only when the transformer voltage was reduced to 400. Upon raising the voltage to normal, things appear to be OK while the key was held down but in keying violent sparking again resulted. This was with the key in the center tap.¹

The reason for this was that the charging current for the 3-microfarad condenser was not in phase with the load current and the brushes had to be shifted to eliminate

ing it, each time shifting the brushes to eliminate sparking, I finally got into synchronism.

But now what was going on? The plate transformer was smoking because of overheating. After shutting down to let it cool off, I started up again and worked stations for about ten minutes with the same result, overheating. This showed something radically wrong. I found the plate trans-

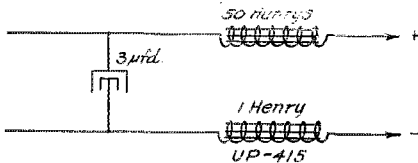
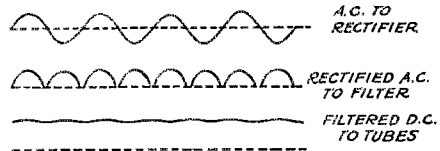
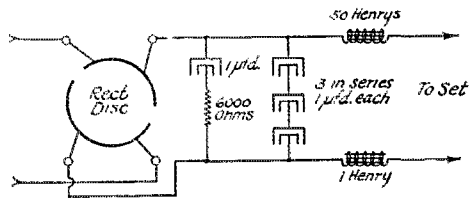

FIG. 1 THE FILTER ORIGINALLY USED WITH KENOTRONS Note especially that there are chokes in both sides of the line in this and the following filters

the sparking. This threw it off for the load, so I had to key the primary of the plate transformer. With the key in that position it took about two days of juggling to get the brushes set in the correct position, due to flashing over. After cutting the transformer voltage down by the use of a primary rheostat, and gradually rais-

former drawing an excessive primary current although the rectifier output was correct. I then decided that the charging current for the 3 microfarad condenser was so large, due to leakage, that it would be impossible to use that much capacity. The reason for this high charging current is that, when the brushes cut across the open space on the disc the input is completely off for a longer time than in the case of any other rectifier, hence the condensers have a greater chance to leak and must be charged. This was checked by taking off the load and synchronizing to the filter an open circuit, noting that when the key was down, (key in primary of plate transformer) a high primary current was flowing.

The note with this arrangement was good as I discovered by listening to forced oscillations on higher waves.

After finding what had to be done, I took off one condenser leaving 2 microfarads, but the transformer primary current was still high. I took off another and then—"N.D." With 1 microfarad I could not synchronize. Fire flew from the "sync" until

1. It is not clear whether the author refers to the center tap of the plate transformer or (what is more probable) the so-called "common lead." In the former position the key is required to break the A. C. input to the rectifier. In the latter position the key, aided by the blocking action of the tube is asked to break the D. C. input to the tube.—Tech. Ed

2. Calculations do not support this explanation but check tests did give the same results.—Tech. Ed.

*WAMU, Marshalltown, Iowa.

it looked like a 4th of July pin wheel. I then reduced the capacity still further by connecting the three condensers in series giving a capacity of $1/3$ μ f. The tone was then as pure as before and surely D.C. was going to the plate. The transformer did not heat abnormally and everything seemed all right, but when keying was attempted, small dribbling sparks trailed after the brushes when opening the key. These did no special immediate damage but were very undesirable, as in time they would burn the brushes and segments.

The problem now was to design a filter to place immediately across the wheel to "soak up" this decaying current which caused the sparks. This filter had to be open to D.C. and closed to pulsations. A condenser serves this purpose, but any capacity across the wheel lead to disaster. Knowing that a high resistance would help reduce this charging current, so that a condenser across the wheel would not upset things, I took an old $1/2$ Kw spark transformer secondary (resistance to D.C., 8125

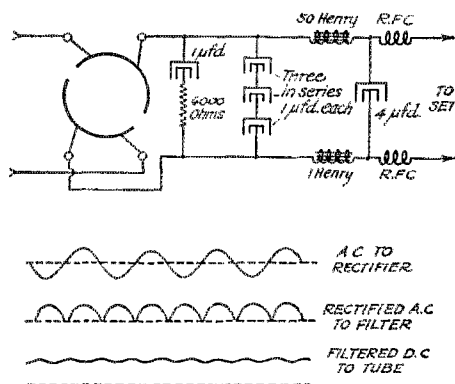

Dotted lines are zero lines

FIG 3

ohms) from its core, and used it for the resistance in series with 2 microfarads across the wheel.³ This worked wonders and took out all the sparks of keying and did not interfere in any way with the filter system. All cards coming in reported "pure D.C." These reports I could also verify by forced oscillations on high waves and listening on my B.C. receiver.⁴ This being the result, the job was done.

Fig. 2 shows the circuit now used, together with oscillograms showing the nature of the output. At the time of taking these oscillograms a small choke of un-

3. A pure resistance of 8000 ohms can be used.—Author.

4. Good! The report cards are usually not trustworthy unless they come from nearby points—40 miles or less.—Tech. Ed.

known inductance was being used in place of the one henry choke. When the UP 415, one henry choke was replaced the tone was better and another oscillogram would undoubtedly have shown an even smoother current. The D.C. shown was fed to a broadcasting set of 500 watts input just to test its qualities and the resulting output was as good as with the generator system that was ordinarily used at the station. Modulation and carrier were OK.

The circuit of Fig. 3 was one of the poor systems tried.

Note that the filter giving the good results is simple, easily assembled and comparatively cheap, with an additional protection of having three condensers in series which raises the maximum allowable voltage three times.

Use this on any transmitter on any wave and if radio frequency is kept from entering the filter circuit, by introducing chokes in all supply leads, the note obtained will be a pure whistle.⁵

A condenser on the load side of the reactors as in Fig. 3 does not apparently add anything to the good work of the filter. Such condensers might be used as radio frequency by-pass for the set, but should be on the set side of the radio frequency chokes.

5. There can be all sorts of exceptions to that rule. A good plate supply does not insure a good note. At a distance audio-frequency fading may spoil the note, when one is nearly the residual ripple can be heard. However the great majority of poor notes is due to something entirely different—sloppy construction and sloppy adjustment. No set will emit a pure note if it is adjusted to give the last possible milliamperce of antenna current, neither is a pure note possible if the operation of the key causes the frame of the set to vibrate. That's where most of the "audio fading" comes from.—Tech. Ed.

Strays

The Headquarters outfit certainly did appreciate the many Xmas cards, OM's. We wish we could take a few days off and QSL each and every one of them personally. Please accept this as a small measure of our thanks to each and every one of you.

The Executive Radio Council of the Second District announces the holding of its sixth annual radio show and convention at the Hotel Pennsylvania, New York City, on March 8th to 13th, inclusive.

5AVC reminds us that copper strip from Mr. Ford's magnetos makes excellent inductance material, antenna and counterpoise "wire," ground wire, connecting strip and so on. There are about fifteen coils on the stationary part of the magneto. Each coil has about 10 feet of strip. The insulation can be removed easily.

Experimenters' Section Report

The Business of Experimenting

THE new outlines for this section have created a lot of interest in the general question of "Why is an outline."

There are several reasons for outlines. Many people (especially very young experimenters) are of the opinion that they can start an experiment satisfactorily without laying it out in advance. This is absolutely not correct. It is of course possible to waste a great deal of time on unnecessary preliminary drawings, diagrams and plans. However, that doesn't prove that the idea is a bad one; it simply proves that you can overdo a good thing. The whole business is somewhat like taking an automobile trip. If you are trying to go to some particular place through unfamiliar country you should certainly have a road map. It isn't necessary to follow your route exactly. When you come to an interesting by-way by all means follow it and see where it leads because you can always follow it back again, come to your state highway and go ahead.

Rambling

Of course there may be lots of fun in starting out some morning to "go nowhere in particular and expect to get there." So also there may be fun in starting out to play with a collection of apparatus, "just to see what it will do." However, that isn't experimenting, that's monkeying.

Even monkeying or tinkering is sometimes excusable, although very rarely. Once in

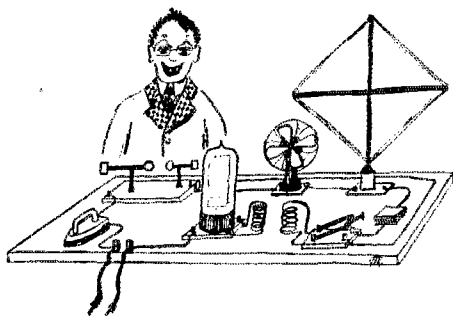

"——that isn't experimenting; that's monkeying."

a great while one does by blind luck and awkwardness run across something interesting. However even then it will never amount to anything unless the process of tinkering is promptly dropped, everything that has been noted is put down carefully on paper and the plans laid for a careful experimental checking up of the things that have been noted.

A Good Start, A Bad Finish

Here is perhaps where most amateur radio work fails to get anywhere. The amateur will notice some interesting thing and will immediately jump to the conclusion that the thing is good just because it's different. He wants all hands to build the same contraption. This is nonsense. The only way to

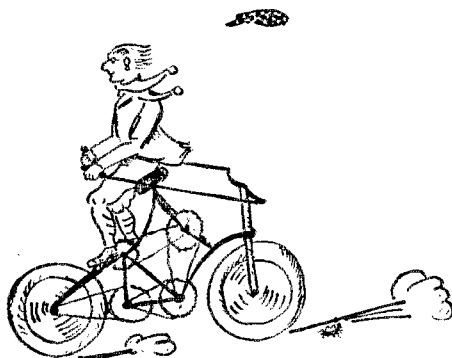

"——wants all hands to build the same contraption."

find out when a certain thing will work is to try it at a number of stations, with different combinations of apparatus and, if it has anything to do with transmission, to try it at different times of the day and year and at different distances. Of course, that is much more work but it's a pretty general rule that things that are worthwhile cause more trouble than the ones that are not worthwhile.

Some Examples

As examples of the things that can be done by planning a job, keeping notes on what one is doing and changing the plans if necessary, we can pick the following from the past year QSTs at random. This list isn't supposed to represent the best that has been done but simply the first ones that I came upon in running through the year's copies. The tiresome old row about the best type of coils was settled pretty permanently by the two articles "The Coil Question" by Dr. Greenleaf W. Pickard and "What Size Wire?" by F. J. Marco. Previous to this time there had been a lot of wrangling but nobody had seriously gone through the thing under absolutely practical conditions. In the transmitting field we have first of all the article "Pioneer Short Wave Work," telling of the beautiful 3 and 5-meter work done by Frank C. Jones and his co-workers. In this same short wave region comes "Practical Lecher Wires" by Eugene

C. Woodruff. In the more usual wavelengths we have Oliver Wright's joyous "Loops and Fords" which is a humorous recital of a perfectly serious piece of work. Experiments going somewhat into the measurement side of radio are represented by "Checking Up Wavemeter Methods" by Austin Lidbury.

Simple Experiments

The experiments listed represented widely different amounts of effort. Even simpler experiments than these can be made to very good advantage indeed. Consider for instance such very simple work as "Key Thump Filters" (November issue) and "Why Not Screened Condensers?" by L. W. Hatry in the same issue.

Recording

All of these things, transmitting, receiving, measurements, whether they are simple or complicated, owe their value to one thing and one thing only. The men that did the work kept a careful record of what they did. If they had not done this none of these *QST* articles would have been possible and all of the work would have been just additional contributions to the junk yard of wasted efforts. That is why outlines and records are worthwhile.

And Now the Outlines

Having talked over the usefulness of outlines and the usefulness of records one can see fast enough why this section wants outlines for every man who is working and

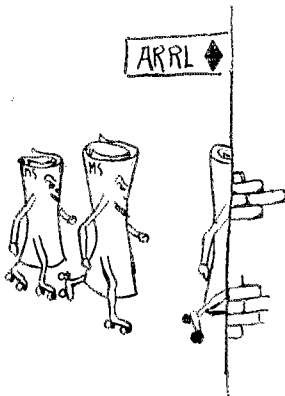

"—all these things become *QST* articles—"

wants every man who is working to make good records so that he can compare his work with the other men. Whether all these things become *QST* articles is not important. Even if they do not they will be worth a great deal more to the men doing the work if these things are done carefully, not only because the experiment will get further but also because there will be so much more satisfaction in the whole thing

when it is talked over with other amateurs.

It is hardly to be expected that anyone at the headquarters office knows all subjects best. We know for a certainty that nobody at the headquarters office has time enough to write the outlines anyway. That is why we have asked for outlines from the membership and that is why we are not asking for many more in addition to those that have come in. There is nothing special about the writing of these outlines. After that there is no precaution but to remember that the man doing the experiment is quite likely to be limited as to apparatus and likely to overlook some of the mistakes that he might make. But then, that's the sort of thing taken care of in all outlines such as are used in school laboratories.

—R. S. K.

A Good Hydrometer

THE automobile storage battery type of hydrometer does not fit itself ideally into radio use. It has a number of disadvantages that are really drawbacks to

its convenient use as a storage B battery device. It causes a lot of inconvenience and is likely to cause a lot of sulphuric acid burnt holes in carpets and clothes because it is sloppy to handle. With these things in mind the Robert Bosch Magneto Company of New York City is offering a little hydrometer that is a "pip". It is so small that it will fill itself and immerse the float from even the smallest storage B. With the Bosch hydrometer one does not have painfully to fill a cup if electrolyte gotten from the B battery either by means of a syringe or a siphon. It is also provided with a "drip loop", an ingenious glass loop in the nipple of the tube preventing any residual electrolyte from spilling on the floor or on your Sunday pants. It can be laid flat on your best table without any danger of the electrolyte left on the outside of the glass spilling on the table for it has a number of glass "feet" moulded in the glass container; these feet keep the end of the tube off the table.

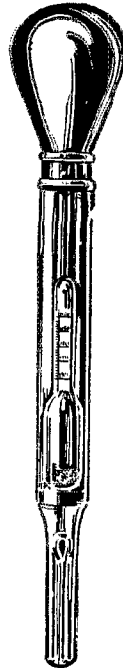

Strays

An unfortunate error in the write-up of the Marco vernier dial appeared in the December issue. The vernier ratio is about 12 to 1 instead of 6 to 1.

Calibrating Your Wavemeter From a Quartz Crystal*

By John M. Clayton, Asst. Technical Editor

AN oscillating crystal whose fundamental wavelength is known can be used not only as a wavelength standard, but also as a means whereby a wavemeter can be calibrated readily. Every amateur can have his own wavelength standard, a standard whose accuracy years from now will depend only upon the accuracy of the original calibration. No need to worry over WWV or 6XBM transmissions of standard frequencies, and no particular cause for worry if a wavemeter coil is lost or damaged, for it is a comparatively simple job to calibrate a new coil from the quartz standard.

The Crystal Oscillator Circuit

The crystal oscillator circuit is shown in Fig. 1. The tube should be a 201-A with 45 or 90 volts on its plate. A coil (L) and condenser (C) are connected in the plate circuit. The coil can be one of the General Radio plug-in type (in case more than one crystal is to be used as a standard) and the condenser (C) should have a maximum capacity of 500 μfd . The milliammeter (MA) is a 0 to 5 D.C. instrument used to show when the crystal is oscillating. Provision is made for listening in the crystal tube circuit by means of the closed circuit jack (J). The filament resistance is an Amperite or other fixed unit, as the filament current does not have to be varied. The quartz crystal is connected between the grid and the switch arm of the two-point switch. Usually this switch will be set on the "F" contact, although with some crystals better oscillation is obtained when the crystal is connected directly between the grid and plate of the tube, as is the case when the switch is on the "P" contact. The by-pass condenser (C1) should have a capacity of 2000 μfd .

When the condenser (C) is varied from its minimum capacity toward maximum the current in the plate MA will vary somewhat in the fashion shown in Fig. 2. As soon as the plate current starts to fall off, the tube is oscillating by virtue of the crystal control. A further increase in the condenser capacity results in a further decrease in plate current until the plate current drops to its minimum value. All this time the tube has been oscillating strongly, and the

crystal is generating a large quantity of strong harmonics. As soon as the crystal oscillates a change in the capacity of condenser C has no effect upon the frequency of these oscillations, only the output from the tube is changed.

By means of an oscillating receiver it is possible to spot the harmonics down to and even below the 20th. If the receiver is tuned to these harmonics and adjusted for zero beat it is simple to transfer the wavelength of the harmonic to a wavemeter. The process is simple but the utmost watchfulness should be exercised in hunting down the various harmonics. It is distressingly easy to lose one and thereby to cause all work beyond that point to be incorrect.

The Auxiliary Generator

Instead of a receiving set it is much handier to have a small continuously variable generator or driver. This device has a number of uses outside of wavemeter calibration, and is an instrument that should be found in the lab equipment of every

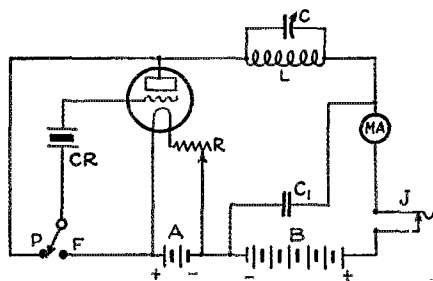

FIG. 1

amateur radio station. The generator is simply a 201-A tube in a Hartley circuit. The inductances are General Radio type 277 plus a homemade one for the shorter wavelengths. The tuning condenser has a maximum capacity of 250 μfd . A 0 to 1 D.C. milliammeter is inserted in series with the grid of the tube. This meter is used to show resonance between the generator and any other tuned circuit to which the generator may be coupled.

Suppose we want to measure the wavelength of a condenser-coil combination. The coil is loosely coupled by the driver coil (L). By loosely we mean several feet. As condenser C (Fig. 3) is varied the grid current will rise gradually from a very small value up to 1 milliampere. If the tube is not

* Much of the information contained in this article was abstracted from the Bureau of Standard's Letter Circular 183. Thanks are also due Dr. August Hund of the Radio Section of the Bureau for suggestions contained in the article.

oscillating the grid current will remain near zero. At about midscale on the condenser C the grid current will start to decrease, gradually falling off to a value near zero as the condenser capacity is increased. When resonance between the coil-condenser combination and the generator is reached the generator grid-circuit milliammeter will dip sharply. The closer the coupling between the circuit under measurement and the generator the more pronounced this dip will be. At exact resonance the dip will be at a maximum. If now a wavemeter is coupled loosely to the driver the grid milliammeter of the latter will duck again when the wavemeter is brought in resonance with the

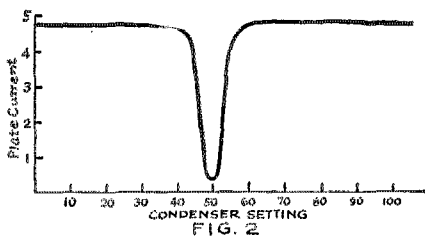

driver. The wavelength of the circuit under measurement can then be read from the wavemeter.

The coupling between the driver and the circuit under measurement can be extremely loose and still a good deflection of the milliammeter can be found. The grid meter is one of the most sensitive and rugged resonance indicators. Its accuracy is second to none.

Calibrating a Wavemeter

Assume you have a crystal whose fundamental wavelength is 300 meters, and you wish to calibrate a wavemeter to cover the amateur bands. Let's see how it's done.

Start the crystal oscillator, varying the condenser in the plate circuit until the plate milliammeter begins to show a falling off of plate current. Couple the auxiliary generator very closely to the crystal oscillator, so that the coils in the respective instruments are not over two or three inches apart, insert the headset plug in the auxiliary generator's plate circuit and vary the wavelength of the auxiliary generator by turning the condenser C. A series of beat notes will be heard in the headset. When the generator is nearly in resonance with the crystal oscillator the beat note in the headset will be much stronger than the other beat notes. By means of the vernier on the generator's condenser adjust the generator until zero beat has been secured. When zero beat has been found there will, of course, be no note in the headset, but as the condenser is varied on either side of the

zero beat the beat note will reappear. When zero beat has been found hold this adjustment. Zero beat, it will be remembered, is obtained when two oscillating circuits are beating on each other, but are so nearly in tune that the beat note is below audibility. To either side of this position a beat note will be heard, rising rapidly as the circuits are run out of tune. The crystal oscillator and the auxiliary generator are now in resonance.

Now bring the wavemeter up to within a foot of the auxiliary generator, coupling the wavemeter to the generator. Slowly vary the condenser in the wavemeter circuit, at the same time watching the grid circuit milliammeter in the generator. When resonance between the generator and the wavemeter is reached the grid milliammeter will duck. Listen carefully when this happens. If the beat note reappears in the headset loosen the coupling between the wavemeter and the generator until the zero beat silence is maintained when the generator and the wavemeter are in resonance.

The wavemeter is now in resonance with the generator. The generator has previously been tuned to resonance with the fundamental of the crystal; therefore the wavelength setting of the wavemeter for this particular point is equal to the fundamental wavelength of the crystal, which in this case is 300 meters. Record this. Do not touch the crystal oscillator throughout the following adjustments.

Next slowly vary the condenser in the auxiliary generator toward zero until another beat note is heard. Be sure that this is the first beat note below the fundamental

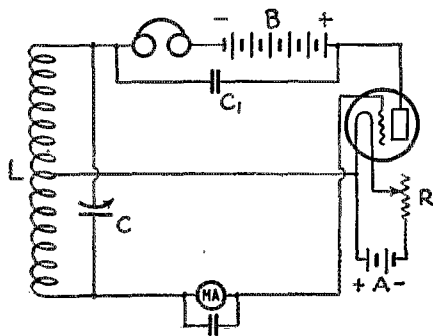

FIG. 3

of the crystal. Make certain by running back to the fundamental and trying again. This second beat note is caused by the fundamental of the auxiliary generator beating with the second harmonic of the crystal oscillator. Adjust for zero beat and couple the wavemeter to the auxiliary generator as was previously done. Again vary the

wavemeter condenser until the grid milliammeter dips. The point of maximum deflection indicates that the wavemeter and the generator are in tune. This wavelength is the second harmonic of the crystal's fundamental—one-half of the fundamental wavelength of the crystal, or in this case 150 meters. From here on the points of calibration should be recorded on cross section as the calibration proceeds so that any wild points or wrong harmonics can be detected immediately. An error frequently made at this point is to obtain a two-thirds setting instead of a one-half setting. The reason is that a fairly strong beat is secured when the second harmonic of one oscillator encounters the third harmonic of the other one. It is necessary to have an approximate idea of the location of the point in advance to avoid having this happen.

Next proceed to the third harmonic of the crystal oscillator by further turning the generator condenser toward zero. Listen carefully in the headset and do not skip any harmonics. If a wild point turns up on the cross section paper start all over by first

Always remember to divide the fundamental wavelength of your crystal by the number of the particular harmonic you happen to be listening to. The result is the wavelength of the harmonic, and the wavelength of the wavemeter adjusted to resonance at this point.

A 5-meter wavelength standard is a nice thing to have around. If you have a crystal whose fundamental is 40 meters you can pick off very useful calibration harmonics at 20, 10, 8, 5, 4, 2.5 and 2 meters.

Fractional Harmonics

If a wavemeter is to be calibrated from a 300 meter crystal (as an example) one can obtain the 20 harmonic points for the wavemeter curve. These points will be distributed between 300 and 15 meters, but there will be a larger number of open spaces between points—spaces one knows little about and may worry a lot over. In case there is any doubt about the shape of the wavemeter calibration curve between these open spaces it is possible to fill-in by means of the so-called fractional harmonic method.

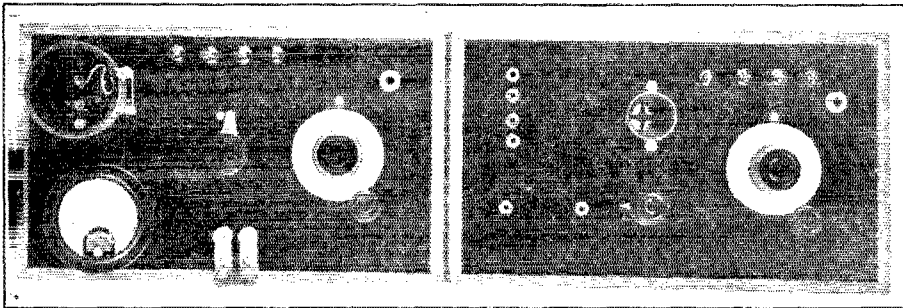

THE CRYSTAL OSCILLATOR AT THE LEFT AND THE AUXILIARY GENERATOR AT THE RIGHT. THE INDUCTANCES ARE MOUNTED WITH G-R PLUGS AS ARE ALSO THE METERS.

listening to the fundamental of the crystal and counting the harmonics as you come down. The third harmonics of the crystal will give a wavemeter point at one-third the wavelength of the fundamental of the crystal, or 100 meters in the case assumed, the fourth harmonic a point at 75 meters, the fifth harmonic at 60 meters and so on.

Before you have gone very far it will be necessary to change the coil in the auxiliary generator in order to make it go down to the lower harmonics of the crystal oscillator. When the last harmonics that can be reached with the coil in the generator is found, record the wavemeter setting for this harmonic, substitute a smaller coil and find the harmonic corresponding to the setting of the wavemeter. Label this harmonic on your record sheet so you will not forget which one it is and start from there down. You can easily make use of 20 harmonics.

This method consists in using the beats between the harmonics of the crystal oscillator and the *harmonics* of the auxiliary generator. If f is the fundamental wavelength of the crystal and F the fundamental wavelength of the auxiliary generator which gives zero beat with the crystal harmonic, then $af = bF$, where a and b are integral harmonics (1, 2, 3, 4, etc). As an example: to obtain one of the fractional harmonic points, turn on the crystal oscillator (adjusting same to oscillate), couple the auxiliary generator closely to the crystal oscillator and place the headset in the crystal oscillator circuit. The generator is tuned to 450 meters and is adjusted for zero beat between it and the crystal oscillator. The second harmonic of the crystal is beating with the third harmonic of the generator. Or $2f = F$,

(Concluded on Page 45)

A. C. Relays

By Harold P. Westman*

IN the course of rebuilding one of the transmitters at 2BQH it was decided to replace the ordinary D.C. relays used in the set with two relays operated from the alternating current supply lines. One relay is used to break the main power leads and the other is used as an antenna change-over switch. As this set was operated entirely from A.C. the elimination of the 12-volt storage battery used to operate the keying relays was well worthwhile.

There are several requirements that such relays must fulfill. The relay used in the primary power circuit is required to break about fifteen amperes. If chattering occurs at the contacts intense arcing would take place. This chattering, it was found, could be reduced in three ways. First, by making the armature very heavy and allowing its inertia to tend to reduce this motion. Second, by using a normal weight armature and connecting it to the secondary armature holding the contacts, through a coil spring. The third method is a combination of the other two. It consists of a reasonably heavy armature and a coil spring having a medium amount of tension. This method was found to be almost ideal.

Positive action is required since both relays have to work together. As the oscillating tube is adjusted with the antenna load on the tube, if the antenna relay breaks first the tube is relieved of its load and the grid current may jump to such a high value that the tube will be ruined. If the power relay does not break with a single snap the arc which is bound to occur as the contacts open will hold and pit the contacts, or even freeze them together permanently. As the set is operated in a residence at night it is essential that the relays do not make a disturbing noise. A slight hum from the power transformer is to be expected. The relays must not make any more noise than this.

With these requirements in mind a number of preliminary tests were made to obtain data on the methods necessary to fulfill all of them. The relay to be described is a

result of these tests and is entirely satisfactory. The core was made of .017 inch regulation transformer core material and fashioned in the usual butt and lap method. A winding of friction tape held it together until the clamp of two brass strips was fitted over the core. Between the strips and the core a layer of sponge rubber was placed. The strips are bolted to the sub panel through two brass posts. A double layer of tape was wrapped over the end of the core to keep the armature from hitting

and sticking to the core. It also reduced the amount of noise at this point by eliminating a metal to metal contact. The winding fits over the core leg opposite to the side on which the armature is pivoted. This winding consists of 400 turns of No. 28 D.C.C. magnet wire having a d. c. resistance of 10 ohms.

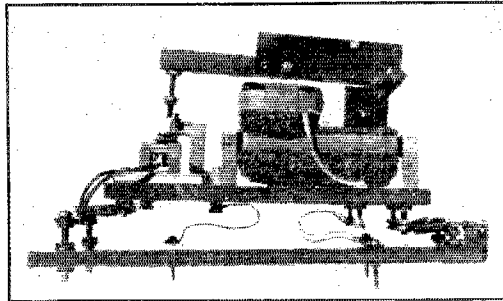

SIDE VIEW OF COMPLETED RELAY NOTE DOUBLE BASE MOUNTING

The core leg on which are mounted the two brass blocks used as bearings for the armature has an extra lamination which gives the necessary clearance at the bearing. The armature measures 4 inches by

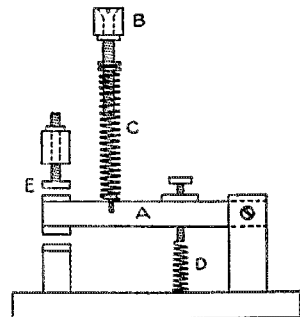

FIG. 1

1 inch by $\frac{3}{8}$ inch and has considerable weight. A square piece of bakelite rod $2\frac{1}{4}$ inches long is bolted to the end of the armature and serves to increase the length of "throw" of the armature and also to insulate the contacts from it. The contacts are quarter inch silver key contacts obtainable from any radio supply house still

*2BQH. In charge, W. R. Seigle Laboratories, Mamaroneck, N. Y.

handling "wireless" keys! The contacts are mounted on a brass bar $\frac{1}{4}$ by $\frac{3}{8}$ inch, pivoted at the opposite end.

At a point midway between the bearing and the contacts a spring C (Fig. 1) is fastened by means of a machine screw. The other end of this is fastened to the bakelite bar B bolted to the armature. An adjusting nut is arranged at the armature end of this bar to allow varying tensions on the bar. Half-way between this spring and the bearing another spring D is attached. Its other

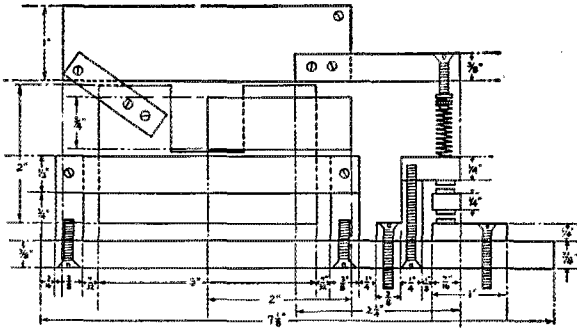

FIG. 2

end presses against the subbase. In adjusting the relay the spring D is adjusted so that, with spring C unattached, it has just sufficient tension to throw the contact armature A against the contact E. Spring C is then attached and its tension increased until it overcomes the back pressure exerted by D and closes the contacts when the magnet armature is about $\frac{1}{16}$ inch to $\frac{1}{8}$ inch from the core.

When the magnet is energized the armature is pulled toward the core and the contacts are closed when the armature reaches a point about $\frac{1}{16}$ to $\frac{1}{8}$ inch from the core, depending upon the adjustment. When the armature is pulled in tight against the core the extra motion is taken up by the spring C. Due to the A.C. field, the magnet armature will tend to vibrate and this motion, which will be only a few thousandths of an inch due to the inertia of the heavy armature, will be entirely taken up by the extra tension of C. There is no actual motion transmitted to the contact armature, although there is a variation in the pressure being applied to the contacts.

When the magnetizing current is cut off, the armature under ordinary conditions will tend to break sluggishly and this would allow an arc to be maintained at the contacts. In this case, however, the contacts do not start to break until the magnet armature has travelled at least $\frac{1}{16}$ inch from the core. By this time the core magnetization has been reduced practically to zero and the momentum of the magnet armature

aided by the spring tension of D results in a very snappy breaking of the contacts. No back-stop is provided in this particular relay, as the full weight of the magnet armature is used to hold the contacts closed in the receiving position. The power control relay is equipped with a back-stop, as only one set of contacts is used.

Power for the relay was supplied through a step-down transformer of the "toy" variety. Thirty volts was applied to the magnet windings. When the current is turned on about one ampere flows through the winding until the armature completely "makes" and then, due to decreased reluctance in the magnetic circuit, the inductance and reactance of the winding rises to a value several times its initial one. While the armature is in the normal closed position only a few milliamperes flow in the circuit. The current may be left on for an hour and no appreciable amount of heat will be generated in the core.

If the relay is mounted on a solidly heavy base the double base and additional spring suspension is not absolutely necessary. When using the double base arrangement the relay may be mounted anywhere without any noticeable hum. Flexible leads were used to connect the contacts with the binding posts provided at the main base. Both bases are constructed of quarter inch bakelite.

Strays

Alpha Sigma Delta is a fraternity of radio amateurs at college. There are now chapters at Oklahoma University, Oklahoma A. & M. College, Massachusetts Institute of Technology and Iowa State College. Any collegiate radio club or unorganized amateurs at college are invited to make inquiries to the Grand Secretary of Alpha Sigma Delta, Box 572, Norman, Oklahoma, if their college is west of a line drawn between Chicago and Mobile; or to Killian V. R. Lansingh, Room 10-189, M. I. T., Cambridge, Mass., if the college is east of this line.

Mr. and Mrs. 9ZT together speak Swedish, French, German, Latin, Spanish and English, not to mention American. They can be QSO almost any country without having to say "no savvy."

Entering Radio Engineering

By Robert S. Kruse, Technical Editor

THERE is quite a responsibility in attempting to help someone else to lay out his life work therefore, in self-protection, I am going to ask that you consider anything said here as a personal opinion and do not value it beyond that.

An increasing number of our members has been requesting of me a statement as to the best way to begin the business of becoming a radio engineer. Inasmuch as I did not regard my own opinion as sufficiently good it seemed advisable to secure the opinions of leading teachers of electrical, and particularly of radio engineering. A rough draft of this present article was therefore made and was submitted to a number of electrical engineering faculties. The agreement between the opinions of the teachers so consulted was surprising and gratifying inasmuch as they were men of widely varying experience. Perhaps, therefore, one can say that that which follows is not only the personal opinions of a technical editor but is rather his wording of the opinion collected from several men prominent in the engineering field and in the teaching of engineering.

Generally speaking the basis of all engineering is the same. There has been current an illusion that radio differs from other branches of engineering and that there is something peculiar and mysterious about it which enables radio engineers to ignore the fundamentals which underly all engineering whatsoever. This illusion is dying a gradual death.

It thereby becomes reasonable to say that the basic thing is to obtain that equipment which will be useful in any branch of engineering and on this basis to place whatever specialized information may be necessary for the radio field.

Proceeding on this belief one should pick a good solid engineering school and in it dig after the fundamentals which are comparatively few in number. I should say that they were, a thorough familiarity with mathematics up to and including calculus, the ability to express thoughts cleanly and clearly in the English language, an understanding of the elements of mechanical engineering and civil engineering, as much understanding as you can obtain of that peculiar animal known as the human being, and finally all the practical experience that you can possibly crowd into the summer periods of your college career. If you can add some business law and some accounting they will not be amiss.

These things which I have mentioned are common to all engineering. If you are going into the electrical end of the thing there

will of course be added electrical measurements, dynamo machinery, the theory of alternating currents (especially transients) and something of electro chemistry. For the wider viewpoint that it gives one a foreign language can well be added and I think of none that is likely to be as valuable later as is Spanish.

All this is still only general electrical engineering. Beginning with such a basis a man with an active mind and with industry can break into any branch of engineering on comparatively short notice.

For the first two years of the technical course forget all about your ultimate intention to get into radio and *plug on the fundamentals*, most especially on the basic mathematics, the use of the English materials and the strength and property of materials, and engineering drafting. In the vacations between these years make every effort to get work of a nature which will give you the broadest possible insight into the engineering game. I do not think much of ship radio operating in this connection except as it serves to show the most difficult conditions under which radio apparatus is required to work. One season of it is however very highly useful in another connection, that of putting you in contact with widely varying sorts of human nature and that after all is information useful in any undertaking.

Do not be too much afraid to gain experience other than radio on the ground that "that isn't in my line". Very few engineering students know before the senior year just what line they really are in and a good many of them don't know it for several years after graduation. Therefore don't narrow your vision down to your particular line but try to learn as much as you can about the engineering game as a whole. Very few of the things that you learn will be wasted no matter what you may specialize on in the end.

Summing up then we may say that the man with a sound general engineering training behind him can always add specialized radio training to the same. The combination will give him the possibilities of becoming a true radio engineer of a goodness depending entirely on his mental ability and his industry. Such a man is in the same class with the thoroughly trained mechanical engineer who can if he wishes, break into the design of (let us say) automobiles. It will take hard work and experience but he is fundamentally fitted for it and can do it.

The "practical radio man" without any engineering training is like the garage mechanic. Both of them are able to cure

particular troubles in apparatus already constructed for them by somebody else; both of them are able to operate this apparatus more skillfully than the designer did. However both of them are quite incapable of adding particularly to the progress of the art. Design and research are beyond them. "Tying in" the things they observe to other things in engineering is equally beyond them. For these things one needs the general engineering basis about which I have talked so insistently.

A Resistance Coupled Amplifier

FOR years radio engineers have been trying to produce the perfect reproducing system—the perfect audio frequency amplifier and loud speaker. High ratio transformers, transformers having a definite and sharp peak at one audio frequency, and other forms of distortion-producers are no longer sought after. In line with this progress toward good and faithful reproduction many minds have turned to the resistance coupled amplifier, theoretically a distortionless device. One of the pioneers in the production of a complete resistance coupled amplifier for broadcast work is the Daven company whose Super-Amplifier is one of the prettiest mechanical jobs we have ever seen. The sockets, resistance clips, baseboard, wiring channels and binding posts are moulded in one piece of black bakelite.

To be used in connection with this amplifier this company has designed a special high mu tube having an amplification constant of 20. The plate impedance is exceptionally high and is designed to work into the high-resistance coupling units in such a manner that maximum transfer of power will be secured. As there is no loud speaker having the necessary high impedance to

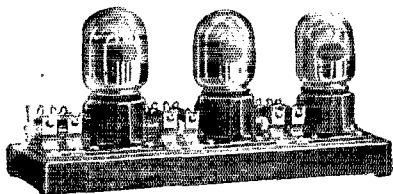

match the high mu tube, a lower-impedance tube is supplied for the last stage. The tubes are designed to work directly from a six-volt storage battery, no rheostat being required.

The amplifier, using three resistance-coupled stages, gives about the same volume as a two stage transformer coupled affair. Compared to the ordinary run of transformer-coupled audio-frequency amplifiers the resistance unit gives a great deal less distortion.

CALIBRATING YOUR WAVEMETER FROM A QUARTZ CRYSTAL

(Continued from Page 41)

and $F=2/3f$ —if the wavemeter is brought in resonance with the generator it will be tuned to $2/3$ of the fundamental of the crystal, or 200 meters. In like manner a great variety of other combinations can be found in which the resulting beat note will be a useful point to fill in a wide open space in the calibration curve. Such values as $3/4f$, $2/3f$, $2/5f$, $5/4f$, $4/3f$, $3/2f$, $5/3f$, $7/4f$, etc., may be useful.

Obtaining the Oscillating Crystals

We have talked a lot about oscillating crystals but have not said so much about where they can be obtained. Here is the line-up: The General Radio Company, Cambridge, 39, Mass., supplies them in three classes, one for calibration purposes with the fundamental frequency measured to $1/10$ of 1% and this fundamental within 25% of the frequency specified. For wavemeter work this is all that is needed. The G-R class two is the same as above except that the wavelength is within 5% of the specified wavelength, and class three is the same except that the wavelength is within $1/10$ of 1% of the specified one. Crystals are not ground below 100 meters. The Scientific Radio Service Company of Mount Ranier, Maryland, supplies crystals ground to oscillate in the 40-, 80- and 150 to 200-meter band to an accuracy of $1/10$ of 1% and are equipped to grind them to your specified wavelength in these bands with the same accuracy. The Hodge Optical Company of Savannah, Georgia, is prepared to furnish crystals guaranteed to oscillate in the 80- and 150 to 200-meter band, but not guaranteed accurate at any wavelength. The Master Optical Company of New York City furnishes crystals cut to your specifications, cut along the correct axes but *not* guaranteed to oscillate. You can cut them yourself from directions given in the November issue of *QST*—if you have time and patience.

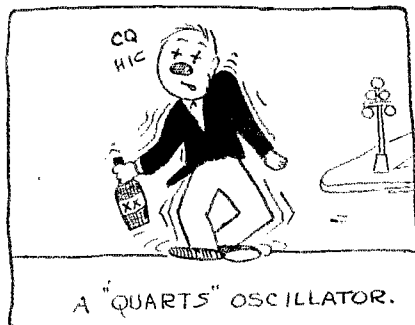

Receiving Conditions in England

By W. M. Bakewell, g6UZ

The following is an address, delivered before the Third National A.R.R.L. Convention at Chicago, by Mr. Bakewell. It was an "after-dinner speech" and, as an example of that rare thing, a good, extemporaneous after-dinner speech, we thought it particularly fine. As a picture of radio conditions in England, it is very interesting. During the months since the talk was delivered, however, there have been changes in the regulations, which Mr. Bakewell mentions, governing amateur transmitters. These have been reported from time to time in the I.A.R.U. News department.—Editor.

IN TALKING to you of our receiving conditions in England, I propose first to tell you of our broadcasting conditions. We have some 21 stations in all, operated by the British Broadcast Company, Limited. Of these, 10 are main stations situated in the principal towns, 10 are relay stations in the smaller towns and one a super-power station.

The main stations have an input of 1,500 watts, the relay stations 200 watts input, the high power station 25 kilowatts, the largest and most powerful broadcasting station in the world. The wavelength used by these stations is 300-500 meters except the high power station which has a special wavelength of 1600 meters.

These stations work from 11:30 in the morning until 11:00 at night. Continental time is the same as English time and although there are broadcasting stations in practically every country in Europe, these too shut down round about midnight. Reception is excellent on this broadcast band. We do not have high power electric lines everywhere like you have and due to the high cost of power, few electrical devices in use in our homes, so one of your main causes of interference we haven't got. In fact the chief cause of interference on these waves is oscillation of receivers, the B.C.L.'s own fault. I am glad to say the B.B.C. appreciates this and broadcast each week technical talks on how to overcome this evil. The ham also helps.

You must remember also that we have many ports in England and have a lot of interference from shipping, but the matter has been taken up by the postoffice and the B.B.C. and that trouble is also being gradually eliminated.

By far our greatest trouble on broadcast lengths is oscillation. One is allowed to use reaction direct on to the antenna "provided no interference is caused to other stations", but by education and help from our radio societies this will go; but it is hard to convince a B.C.L. that when his set squeals he is causing trouble to dozens of others, apart from the fact his own reception suffers.

For broadcast reception, a straight three tube is the most popular of the tube sets,

using one R.F., detector and from one audio step up; but at least half of our B.C.L.'s use crystal sets. Super "dyne" sets have not yet found favor in England. In passing it is interesting to note that in winter two or more Eastern American broadcast stations can be received easily on three tubes.

The ham is not loved in England, so that apart from the difficulty in getting a license to transmit, when you have got it you are only allowed to use 10 watts on 150-200 meters and not to work outside the country. Any other facilities are to be got only with very great difficulty. For example last fall we were the lucky ones, allowed to use waves from 90 to 150 meters with an input of 50 watts between 12 midnight and 3 A. M.—so any interference we caused only upset some other ham. We have little trouble from key clicks as we have only some 10 hams who use 250 watts or more input. They are the *very* lucky ones.

We have one great blessing—we are not allowed to send CQ. Having listened over here quite a bit I can assure you that is a very great blessing. We send either "Test de—" or if we want American stations "A RRL". We had a lot of trouble las fall with French stations using raw A.C., but they have cured that now. Our biggest QRM on the low waves is caused by American hams! Although our population is big for the size of the country, we have not the skyscrapers you have with all their attendant iron work, nor, except in London, have we the congestion in our residential district. As a result we are able, most of us, to erect a good antenna and counterpoise.

I think, however, our greatest gift is lack of static. We do not get anything like the static you get even in your best districts. I don't propose to enter into the circuits we use—they are very similar to yours. I think, however, we do spend more time in making them efficient. Tubes are good, especially the Marconi and the R. Mullard S3. These are, however, bright emitters. We do not seem to have good dull emitters and they have a standard base, which is not so heavy as yours. Their self capacity is also lower. We also get power tubes with high amplification factors and transformers to suit them. The prices are very much

the same as those ruling over here. You do, however, have a big advantage over us in condensers. We have nothing on the market to compare with those over here, especially the vernier dial.

In this talk I have tried just to give you a general idea as to our conditions. I must confess that from what I have seen we do have a big advantage over you in reception. If any of you would like more details I am always glad to answer any questions you might like to shoot me—you have my QRA.

In conclusion I would like to say how much I have enjoyed being at your convention and how much I appreciate the kindness shown me when visiting your station. At your next convention I hope to be with you again and to bring with me some of our other hams like g2NM and g2OD who you know so well—just to liven you up.

A Single-Control Rig

IN tuned R.F. sets employing several stages of amplification, it is often possible to combine the controls so that all the tuning condensers can be handled through the manipulation of one knob. Gang, or multiple, arrangement of all of the condensers on one shaft is one way in which this can be accomplished. Another and newer method is that shown in the illustration. Each condenser has a bakelite gear about an inch in diameter mounted on its shaft, behind the panel. Meshed with each individual condenser's gear is a rack-gear made of bakelite backed with a strip of metal. The rack-gear runs in small micarta spools supported on the condenser through strong wire springs. When one control knob is turned the rack gear commences to operate and slides over the gears of the other two condensers. Each control knob is fitted with its individual vernier operating independently of the gears so that fine

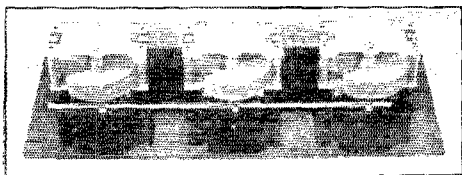

adjustments can be made on any stage of amplification without upsetting the tuning of the other stages. In order to adjust the condensers initially so that they are "in phase" the rack-gear over any one condenser is raised and the condenser set where it should be. The rack slips back in place and all the condensers are controlled as one. This device is called an E-Z-Toon Group Control. It is manufactured by the Kurz-Kasch Company of Dayton, Ohio.

—J. M. C.

Standard Frequency Schedules

THE standard frequency signals from WWV, Washington D. C., and 6XBM Stanford University, California, are as follows. For further information regarding these signals see page 34 of the March, 1925, issue of QST and Bureau of Standards Letter Circular No. 92. The former can be obtained from QST Circulation Manager, Hartford, and the latter from the Bureau of Standards.

WWV and 6XBM

SCHEDULE OF FREQUENCIES IN KILOCYCLES

Approximate wavelengths in meters in parentheses

Time*	Feb. 5	Feb. 20	Mar. 5	Mar. 20
10:00 to	125	300	550	500
10:08 p. m.	(2400)	(1000)	(545)	(200)
10:12 to	133	315	630	1650
10:20 p. m.	(2254)	(952)	(476)	(182)
10:24 to	143	345	730	1800
10:32 p. m.	(2097)	(869)	(411)	(167)
10:36 to	155	375	850	2000
10:44 p. m.	(1934)	(800)	(353)	(150)
10:48 to	166.5	425	980	2200
10:56 p. m.	(1800)	(705)	(306)	(136)
11:00 to	205	500	1130	2450
11:08 p. m.	(1463)	(600)	(265)	(122)
11:12 to	260	600	1300	2700
11:20 p. m.	(1153)	(500)	(231)	(111)
11:24 to	315	666	1500	3000
11:32 p. m.	(952)	(450)	(200)	(100)

*Eastern standard time for WWV, Washington, D. C. Pacific standard time for 6XBM, California.

For the month of February we have the following schedule for 1XM. These transmissions, lasting from nine to eleven P. M., E. S. T., will take place every Friday night during the month. For details of transmission and other information see page 44 of January QST.

1XM

SCHEDULED OF FREQUENCIES IN KILOCYCLES

(Approximate wavelengths in meters in parentheses)

Time (PM)	Freq. k.c.	Time (PM)	Freq. k.c.
9:00-9:07	9100 (33)	10:06-10:13	4300 (69.8)
9:11-9:18	8000 (37.5)	10:17-10:24	4000 (75)
	(U.S. limit)		(U.S. limit)
9:22-9:29	7500 (40)	10:28-10:35	3750 (80)
9:33-9:40	7000 (42.9)	10:39-10:46	3500 (85.7)
	(U.S. limit)		(U.S. limit)
9:44-9:51	6400 (46.9)	10:50-10:57	3250 (92.3)

Dakota Division Convention

AT Vermillion, S. D. under the auspices of the Coyote Amateur Radio Club, South Dakota will hold its 2nd Annual Convention, February 12th and 13th, 1926.

All events will take place at the University of South Dakota, and from reports received the Committee in charge has arranged a wonderful program.

Amateurs in the Dakotas and neighboring states are cordially invited.

—A. A. H.

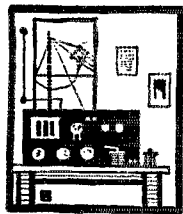

Amateur Radio Stations

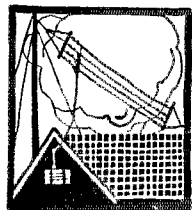

SNY, Hartford, Conn.

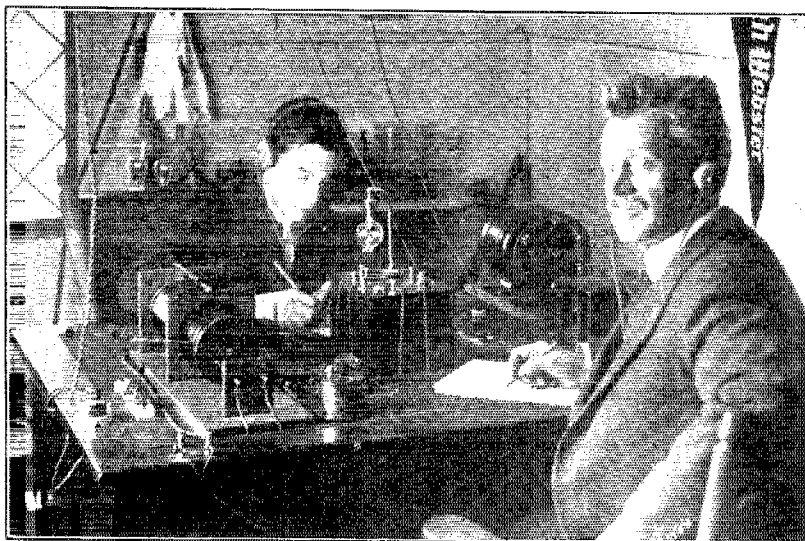

THIS station was owned and operated by our A. R. R. L. President, Mr. Maxim, at 550 Prospect Avenue, Hartford, Conn. The photograph was taken back in the days when radio was wireless and Mr. Maxim was a much younger man. Very old timers will recognize a lot of the "apparatus" in the photograph as relics once manufactured by people who are no longer in the commercial manufacturing swim.

The "audion control box" comes from J. F. Arnold, of New York—long the manufacturer of high class, and equally as highly expensive, special radio receiving apparatus. The crochet-ball audion was the first type put on the market by DeForest. The loose coupler is a home-made affair, generated by Clarence Tuska who afterwards was the first Ed. of *QST*, and who is now of the C. D. Tuska Mfg. Co. The slider on the primary of the coupler comes from the well-known E. I. Company—need we say of Fulton Street, New York? There were two types of sliders sold by the E. I. Company. One was moulded of black mud and the other of

red mud. Otherwise they were identical. We can't tell the color of this one, although there is some relation between wavelength and slider color. Note the taps on the secondary of the loose coupler, and shudder when you think of the dead-ends. The secondary tuning condenser is one of the die cast affairs made popular by the Wm. J. Murdock Company of Chelsea, Mass. We don't know the wavelength range of the receiver, but suspect it was from 600 to 2,500 meters, the amateur wavelengths falling somewhere (usually) within that band of waves. The phones seem to be the ever popular Brandes, Mr. Maxim wearing the small Navy type and the lad across the table the Transatlantic type.

The transmitter used an 8-inch Mesco spark coil giving a spark about 2 inches long when hooked on to the antenna. In order to get the usual high pitched note common in those days the spark coil was equipped with a differential gap, giving a note that was different. Decidedly different, we suspect. There was no condenser across

the transformer secondary. Why should there be? When the spark gap was inserted directly in the antenna circuit that little spark coil must have laid down and groaned for dear life trying to fill the antenna! The antenna probably had enough capacity to soak up a couple kilowatt, anyway. We can't find a key anywhere, but we know there was one around.

We do not know the name of the second op at SNY. If he should by any chance read this will he please step forward and proclaim himself? Oh, yes, we forgot, this picture was taken some years before 1912. Has ham radio changed since then?—Well, slightly. You should see 1AW now!

1BAY, Cambridge, Mass

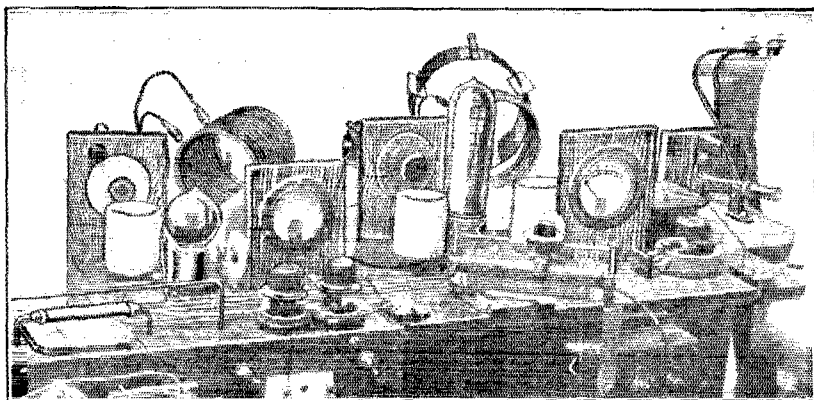

THIS crystal-controlled station is the experimental layout of Lieutenant J. B. Dow of 22 Chatham Street. The set has been in operation for several months and although it has not been on the air very much during this time, it has always given an excellent account of itself when operated.

The antenna is a single wire 80 feet long and 55 feet high. The counterpoise is a lead telephone cable in front of the house in which the station is located. The antenna coil, L2, is 6 inches in diameter and has 8 turns of edgewise wound strip. All of the inductances are wound with the edgewise strip as it was more convenient to mount this form of conductor.

The crystal oscillates at 78 meters by virtue of the L-C circuit in the crystal tube plate circuit. Condenser C has a maximum capacity of 250 μ fd. and there are 6 turns of $4\frac{1}{2}$ inch strip between the condenser clips. Between the top condenser clip and the grid condenser clip of the Master oscillator there are 7 turns. The M.O. grid condenser has a capacity of 1,000 μ fd. as have also the plate blocking condenser C2. The master oscillator is tuned to the second harmonic of the crystal for 40-meter opera-

tion. The L1-C1 circuit is tuned to this wavelength, condenser C1 having a maximum capacity of 120 μ fd. and the coil 5 turns of strip 5 inches in diameter.

In order to make the second harmonic of the crystal oscillator more pronounced a rather high bias voltage is used on the grid of the crystal oscillator tube. This voltage is secured through the IR drop in the 400-

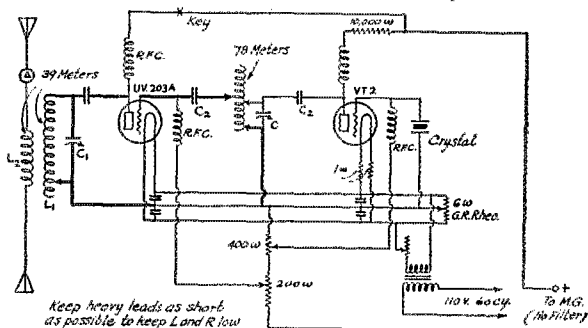

CRYSTAL CIRCUIT AT 1BAY

ohm potentiometer connected in the negative lead of the motor-generator. An additional 200 ohm potentiometer causes the necessary drop for the bias voltage of the power amplifier tube. It would probably be better to dispense with this form of bias voltage as the voltages change somewhat when keying

the set. C batteries would probably be better since the voltage could be held steady.

It has been found unnecessary to neutralize the power amplifier when working it on the harmonic of the crystal oscillator. If the power amplifier were amplifying on the wavelength of the crystal circuit it would be desirable to neutralize the amplifier. Unless the whole layout is thoroughly shielded with copper or brass sheeting this will be a very difficult job.

The crystal oscillator tube is a VT2 and the power amplifier a 203-A. Both tubes obtain their plate supply from a single 1,100 volt motor generator, a converted G. E. dynamotor. A 10,000 ohm resistance is placed in series with the plate of the VT2 in order to reduce the plate voltage to 350

for operation on this tube. Instead of a center tap on the filament transformer, a 6 ohm rheostat is shunted across the filament supply line, and the grid and plate returns are brought to the slider arm on the rheostat. All r.f. chokes consist of 100 turn coils on 2 inch forms.

Lieutenant Dow cut and ground his own crystal. He prefers to operate a 40-meter transmitter on the second harmonic of an 80-meter crystal instead of trying to grind the 80-meter crystal to 40 meters.

1BAY has worked the West Coast a number of times and has a report of R7 from Irish 7HJC. As stated before the transmitter is in the experimental stage and little time is available for operating.

5LG-5SC, Alamogordo, New Mexico

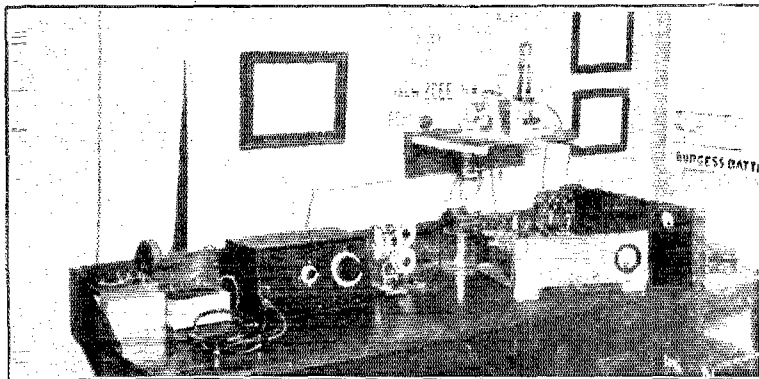

THIS station was first put in operation early in 1923. Since then it has undergone a number of changes, gradually graduating from a single VT-2 in a four coil Meissner circuit to the present layout using a single 203-A in a *coupled* 1DH (reversed feedback) system. Although the DX range of this station is similar to many others, 5LG has been pushing wickedly strong signals all over the Western Hemisphere.

The apparatus layout as seen in the photograph from left to right includes a 7 to 150-meter wavemeter with removable coils, a "Schnell-type" receiver with no audio frequency amplification, the antenna series condenser and antenna ammeter mounted on top of a tobacco humidor and the 40-meter transmitter, the latter mounted on the table. Above the 40-meter set is a 5-meter experimental transmitter using one 50-watt tube. The 5-meter set oscillates like a house afire, but its range is unknown both to us and to Mr. Tatum, the owner and operator of 5LG-5SC.

To the right of the operating desk is the power control outfit. A sixty-four cell

chemical rectifier, arranged in two shelves, plus a small and simple filter constitute the rectifying unit. This unit supplies plate voltage to the tube from an old pole transformer. The filament transformer is home-made. Two small rheostats are connected in series with the primary of the filament transformer to regulate the filament voltage.

The antenna is a long single wire suspended between two 65-foot towers. The transmitter operates at the third harmonic of the antenna. A separate receiving antenna is connected permanently to the receiver. Seventh harmonic transmission has been tried for 20-meter operation but the results have not been so good, due probably to the vast number of absorption ornaments such as trees and shrubbery under and near the antenna. Much better results have been had, on 20 meters, with a Hertz type antenna.

Although 5LG has never been a star performer when it comes to large traffic totals, nevertheless when Tatum finds time to pound brass for any length of time, a good traffic report turns up at Headquarters.



British Section

"The most noteworthy work during November has without doubt been the number of actual contacts with the Far East; Philippines, China, Hong Kong, Indo-China and Borneo having been reported as worked by members of the Section. The times of contact, too, are interesting and in G. M. T. extend from 2 P.M. to 10 P.M., while the reception reports at both ends show that signals from these directions can be heard here as early as 11 A.M. in the morning, and that British signals are heard until 11:30 P.M., G. M. T., at a distance of 8000 miles. It was evident early in the reception of these signals that Philippine stations were working 120 degrees East and West in the Northern hemisphere at the same time around their midnight time. Such a possibility has not previously been evident at Greenwich midnight notwithstanding that we are further from the Equator and should have better conditions. The Section has therefore made the request to Philippine stations to listen for us at 8 A.M. their time, and 6th District U. S. stations should hear us at 4 P.M. Contact should be possible. Observation should also be kept for special British stations using 33 to 35 meters for these tests as well as the usual 44 to 46 meter waves. Similar deduction indicates the possibility that Hawaiian stations should be able to work us this winter at noon G.M.T. Reception during midday conditions on 40 meters has not been confined to the Northern Hemisphere however, as Zedders and Aussies are being heard every afternoon after 1 P.M., working through mild QRM from the U. S. stations, while the author has on three occasions listened to both sides of a conversation across the Pacific. Yank signals are audible throughout the day and although no reports of actual contact during noon have been received in this country, Norwegian LA1A was heard in contact with u1YB on the morning of the 24th of November. The Norwegian station was using an input of only 15 watts and the time was 11:45 A.M. G. M. T. Fine business, OM's and congratulations! Contact has also been kept with the Swedish experimental expedition

returning from South America under the call SGC. This ship is now due back at Gotheborg.

2NM has had to take things easier due to business pressure but he is still doing good work over the week-ends. 2LZ has had further contact with the Philippines and also South African A6N, and has worked China. 2KF does good work on 23 meters during the week-ends. 2AO has been doing excellent work with the new vertical antenna and has worked a station in China. 5LF is reported to be QSO Hongkong. 5NJ in North Ireland has worked Australia and New Zealand and says Eastern signals are good there. He has also been heard in China. 2CC has had a report from KFUH at Tahiti Islands and has been one of the best contacts with SGC. 2OD is still carrying out a regular schedule with a2CM and has worked Chinese GFUP (the first two-way work with Great Britain), and also oA3E of Durban, South Africa." —W. G. Dixon, Secretary.

g2NM, until further notice, will relay the London Broadcasting station programs on 45 meters on Tuesday, Thursday and Friday evenings at 6:15 E.S.T. and on Saturday evenings at 6:30 E.S.T. He is particularly anxious to receive reports from American amateurs who seem to have difficulty in successfully "copying" his fone signals, although he has been heard on voice in India, Bermuda, Canada and many other places.

VT-2BG at Cacher, India reports hearing g5MO while the latter was QSO u1CMX, on October 19th, 5MO also reports that *daylight* reception of signals from piICW, pi1HR, piNUQG, chinaPNP, GFUP in China, huKFUH, huNUZQ, uNEQQ, a3BD, a3BQ, a3YX, a2YI, a6AG, z2XA, oA3E and oA4Z has been done. All these between noon and 5 P M British time! First communication between Australia and South Africa was pulled off when oA3E and a6AG connected on October 26th, g2LZ qso pi1HR on November 9th and g2OD was qso GFUP on November 14th. Boy Howdy—watch the records break *this* winter.

Frank D. Bell

We are pleased to be able to present a likeness of Frank Bell, z4AA, the pioneer DX man of New Zealand. Bell was born in 1896 and while at boarding school (before the war) he met z3AA, z1AX and caught the amateur fever. In 1916 he



Frank D. Bell, z4AA, one of New Zealand's pioneers.

went to France with the N. Z. Field Artillery, was wounded and returned to New Zealand and took over the management of his father's sheep ranch. In 1923 he was licensed as 4AA and was the first z station to be in communication with Australia when he worked a3BD. In 1924 he was the first z station to be heard in Canada



Cup given Bell by N. Z. amateurs for his pioneer DX communication.

and the first in the U. S. and his two-way work with u6BCP was the first communication between New Zealand and the U. S.

In October of 1924 z4AA shared the honors of the first trans-world communication with g2SZ of London. Since then almost all of the civilized countries have been worked. At the Paris conference Bell was elected a Counsellor at Large of the I. A. R. U. The same old U.V. 203 has been in use at z4AA for over 18 months. When it finally expires the owner says he will embalm the remains in electrolyte and write on the coffin in letters of platinum a list of its splendid DX achievements.

There is also shown herewith a photo of the solid silver cup presented to Bell recently by New Zealand amateurs. The cup bears the following inscription: "Presented to Frank D. Bell, z4AA, by the Radio Society of Christchurch, Wangauni Amateur Radio Club, and New Zealand amateurs, in recognition of his being first to establish two way communication with Great Britain".

Chile

The first two way communication between South Africa and Chile was established on October 26th by oA4L of Cape-town and ch2LD, the station of Mr. L. M. Desmaras, Casilla 50 D, Santiago, Chile. oA4L was operating on a wavelength of 40 meters and ch2LD is on regularly with a 50 watt set on 37 meters. ch2LD also has established communication with a2YI, the first contact between these two countries we believe, and lastly first two way work between Chile and Canada took place when 2LD worked c4GT.

Ships at Sea

From Bill Rowan, D. M. of the Vancouver Division, we have received a description of the R. M. M. S. *Aorangi*, GDVB whose signals so many of us have heard on short waves recently. The *Aorangi* is the largest motor liner in the world, and is commodore ship of the fleet of some seventy vessels comprising the fleet of the Union Steamship Company of New Zealand. In addition to an extremely elaborate commercial outfit which includes no less than four transmitters and enough receivers to use 23 vacuum tubes, the ship carries an experimental short wave outfit. Much experimental work has been done on waves between 22 and 49 meters with power inputs ranging between 60 watts and 3 K. W. After innumerable tests it has been found that the best ranges have been obtained when the short wave transmitter is operated on an antenna having a fundamental wavelength of 435 meters. The transmitter is operated on a harmonic of this antenna. Although the traffic on commercial waves is

extremely heavy the operators find time to do a considerable amount of amateur communication. A. E. Hay, g2KG is the Chief operator and H. T. Longyehaye, g2KC, is second operator. They will be pleased to receive reports of reception of GDVB at any time. Such reports should be addressed to A. E. Hay, R. M. M. S. Aorangi, Canadian-Australian Royal Mail Line, Vancouver, B. C. (or Sydney, N. S. W.) The ship regularly plies between these two points.

From C. Sjöholm, operator on the Motor Ship San Francisco we learn a few things

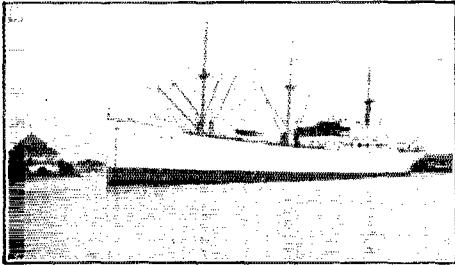

SGC, the motorship "San Francisco."

concerning the short wave installation on the ship, call letters SGC. The transmitter ordinary used consists of a single Telefunken tube having an input of 150 watts operating in a coupled Hartley circuit. The receiver is a Reinartz with a detector and a single stage of audio frequency amplification. The SGC regularly runs between Argentina and Sweden and the operator is anxious to connect with amateurs as often as possible. Two other Swedish ships, SGT and SKA are equipped with short wave apparatus operating around 40 meters, with inputs of 50 watts. SGT runs between Argentina and Stockholm and SKA between San Francisco and Stockholm. The short wave equipment was constructed and installed by Elmquist of SMZS. The operators on these ships will appreciate QSL's addressed care Johnson Line, Stockholm, Sweden.

8ATX of Canton, Ohio connected with the S.S. Southern American, call letters KYOI while the latter was off Cape Horn. KYOI reported his set consisted of a single 50 watt tube, 500 cycle A.C. supply. The transmitter was being operated on the 15th harmonic of the ship's antenna, on 40 meters. 8ATX used four 5 watt tubes.

The United States Coast Guard operates a number of short wave transmitters on and around 143 meters on various Destroyers. A great number of the operators on these ships are ex-amateurs, and are amateurs at heart, still. Any unofficial conversation on the part of the C.G. ships must be necessarily short but the

fellow certainly would appreciate QSL cards reporting their signals. They, in turn, are equipped with W. E. super-heterodyne receivers tuning from 100 to 200 meters, and will be pleased to QSL reception reports of signals from amateurs at any distance. The fellows operating in the 150-200 meter band should particularly watch out for the various "N" calls on 143 meters. We recall with pleasure the splendid work done by 1BBQ in providing steady communication on schedule each night when the Ice Patrol ships Tampa and Modoc were out last season. Give 'em a lift, fellows. They will appreciate it, and so will you.

Communication with AQE, the *Sir James Clark Ross*, continues to be good. It will be remembered that this ship is frozen in an ice pack way down in the Antarctic circle. 6BLS, 6AWT, 5ACL, 5YD and 9APM have reported (in the order named) successful communication with this vessel. She is a Norwegian Whaling ship and probably will be down there for some time. We urge the gang to watch for her sigs and clear what traffic she has to offer. Usually AQE can be found near 40 meters.

Wentworth of 60I reports having worked NTT, the U.S.S. Scorpion, at Trieste, Italy, of December 4th. Fine Business. NTT continues to pour extremely good signals into the East coast and seems to have little trouble in working into the mid-West almost every night. He is on 35.5 meters and uses a single 50 watt tube.

SAVO of Lansing, Michigan, worked jIta AYN giving his QRA as the yacht Connor, 100 miles S.E. Australia. Anyone else hooked this one?

French Indo China

8QQ and LBT of Saigon, Indo China, inform us that they have adopted the in-

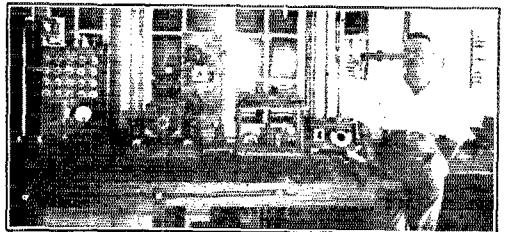

HVA, Hanoi, Indo China.

termediate "ñ". This is an unofficial intermediate and cannot be considered as anything other than a private intermediate until the I.A.R.U. Executive Committee has acted in the matter. Both of these stations are reaching out in splendid fashion. 6AWT reports having worked

8BLT (is it 8BLT or BLT?) on December 18 and 8QQQ on December 2nd.

At last we have secured a photograph of station HVA, Radio Telegraphic Department, Government Radio Station, Hanoi, Indo China. Mr. J. Fournier is the Chief Laboratorian and designed and constructed the station, the photo of which is shown herewith. The transmitter uses four 50 watt tubes. HVA has been QSO France, England, the U. S., New Zealand, Dutch East Indies and Finland. Fournier will appreciate QSL's written to the above address.

Italy

The National Radio Club of Italy has offered some very nice prizes to the best amateur stations in Italy. In order that the stations may be classed correctly it is desired that amateurs from all over the world, and especially from Australia, Africa, Asia and the U. S., promptly send QSL cards to those Italian amateurs who are entered in the contest. The following are contesting for the prizes: 1NO, 1AS, 1JR, 1LP, 1AP, 1AU, 1FD, 1CO, 1AY, 1GW, 1GS, 1RM and 1BS. If you hear any of these stations by all means drop them a QSL card, OM. If you do not have the QRA, send it care of Ernesto Montu, Secretary General, National Radio Club of Italy, Viale Miano 9, Milan, Italy. Montu informs us that during the month of October 1RM, 1AS, 1AU, 1BS, 1CO were QSO Australian 3BQ; 1GW was QSO rAA8; 1AU was QSO a2YH and 1RG on phone has been QSO many European stations.

Norway

A new country worked! 1YB, Dartmouth College, Hanover, N. H. on November 26th at 11 GMT connected with s1ALA who gave his QRA as Maalselv, near Tromsø, Norway. 1ALA said his input was 15 watts and was received at 1YYB with an audibility of R6 to R7. Fine biz OM's.

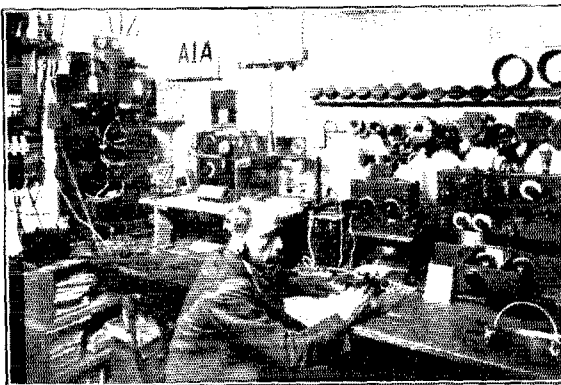

oA4Z, and J. S. Streeter, of Capetown, So. Africa.

An International Call Book

For a long time we have needed a complete, accurate and well tabulated International call book. One could find the QRA of almost all of the stations we hear on the air every night if he took the time to dig and dig and pry around. But that is necessary no longer. A very excellent book, listing over 4,000 foreign amateur calls (and only foreigners) is now available through the International Call Book Company, Drawer 205, Station A, Hartford, Conn. It is worth ten times the fifty cents it costs, too.

South Africa

Schick of 2MU was the first ham to connect with oA6N at Capetown. A half an hour later 8JI at St. John's Michigan, connected with the same station. F. B. g5MO reports that oA3E, oA4L, oA4V and oA4Z have been logged in England. g2LZ's single contact with oA4Z has been the only communication between the two countries to date.

Contact with South Africa gets better and better each night. A number of the U. S. fellows have been QSO various South African stations. Streeter of the well-known oA4Z has worked the following U. S. stations: 1CMX, 3JW, 1GA, 8GZ, 1YB, 1SL, 6HM, 8ALY, 8CYI, 2AHM, 2AGQ, 1CMP, 9DNG, 8ADG and NAH. Also c1AR, g2LZ, rCB8, rAFI and piHR. His communication with 6HM is especially noteworthy. We are showing a picture of Streeter's layout. On the extreme left is part of the battery charging board, next to which is the high tension panel with two Phillips rectifying tubes. The filter condenser is hid behind the "Danger Hi Voltage" sign. Directly in front of the window is the transmitter. A Phillips Z4 tube is used. The four carbon filament lamps compose the grid leak for the tube. Next to the transmitter is the long wave receiver and below this is the short wave set. Note extension handle vernier controls to do away with shielding.

oA4L, R. Oxenham of Capetown has also been reaching out in fine style. He reports having worked u2BW, u2TP, u4RR and u9DNG and a number of r, bz and ch stations. 1AAP reports hearing a4L as does 5PB.

First communication between Australia and South Africa was effected on October 26th when oA3E. Heywood of Durban, hooked a6AG. A3E has also worked a number of r stations and ch 2LD.

In addition to having worked oA4Z, 2AHM of Schenectady has also been QSO, oA6N and oA3B. Rosso of 5KC reports hearing oA3B on several occasions.

Calls Heard



ANNOUNCEMENT

The Editors feel that this Department has ceased to serve a useful purpose. International amateur communication has advanced to the point where the fellow with the "5-watter" can work stations in all parts of the globe, and actually does work many more stations than those who report his signals only as being heard. With international communication a daily and nightly occurrence it is of no value to the brass-pounder to know that his signals have been heard at intermediate points in the U.S. or Canada. The QSL-card idea has been firmly incorporated in the amateur system. Almost all stations send QSL-cards to stations they have heard for the first time when these stations are at any great distance from the transmitter. These report cards reach the transmitting operator at least six weeks before they could possibly appear in *QST*. Therefore the calls heard in *QST* unavoidably are ancient history.

Space in *QST* is always at a premium. We feel that the brass-pounder can be better served if the Calls Heard Department is eliminated, thus allowing three additional reading pages for articles of prime interest to the brass-pounder. After this issue the department will be discontinued.

U. S. S. Scorpion, Trieste, Italy.

1aac laap laei laff lahm laiu laj lajo lajp latq
 lajp latq latv lavf laxa lbal lbdx lbeu lbge lbhm
 lbvl lcal lch lci lcmp lerb leri lef lga lif lje lor
 lpl lpy lrd lrr lse lsi lsw lvc lxx lyb zacs zaev zag
 zagq zank zaky zamj zapv zasw zauh zbbx zbm
 zbpb zbrb zbtb zbxj zcbo zcgy zcbr zeth zctf zeth zcv
 zcvs zcxl zco zfo zgy zku zld zmm zpd zqs zrac zxp
 zaep zafq zah zaih zauv zbpl zca zedv zckj zdh zgp
 zhg zhp zjo zld zlav zch 4h 4i 4j 4k 4l 4m 4n 4o 4p
 4r 4w 4sa 4tv 4ux 4we 5aa 5ew 5mi 5qk 5sp 5ux
 5yd 5zai 6cgv 8adm 8akk 8aly 8atz 8aul 8bb 8bnh
 8bjh 8bth 8buk 8bwp 8bwr 8byn 8cca 8ca 8da 8daa
 8don 8ev 8gz 8ke 8rh 8si 8zu 8adk 8ejw
 9df 9ds 9dmw 9eji 9dvc 9nk 9zk. nah naw nism
 nisp nrrl wiz wir woo Special are fw pox pof aga
 pcuu pemm a2cm a3yx a4bal bzlab bzlan clap
 clar c2ax c3aa c3ep ch2lm elbh elch mik oa4z piab
 rpr rxe z2ac z2xa z3ad.

U. S. Naval Radio Station, Guantanamo Bay, Cuba.

1in 1yb 1adi 1xm 1no 1gr 1ckp bz1co 1ba 2za 2by
 2kx 2aco 2axc 2xad 2xaw 2xli 2cyw 2gp 2be cmm
 2uk 3jo 3ais 3vi 3buv 3eel 4xe 4fc 4rm 4vs 4kw 4rr
 4ts 5ah 5he 5to 5fc 5nq 5mi 5ahp 6st 6bhq 6bk 6awt
 6ar 6cql 6ctd 6bhx 6cqr 6cqa 6csw 6ajj 6kk 6cgo
 6bww 8ayp 8zk 8cxp 8cqa 8xe 8er 8avd 8wa 8agq 9aio
 9lb 9epo 9nm 9rlc.

S. S. Yantar, 100 miles West of Copenhagen.

Denmark.

1ch 1ck 1ga 1rr 1se 1acv 1air 1aja 1azd 1cmf 1cmx
 1yb 2apy 2xu 3lw 3bhv 4tl 5bf 8gz 8cqq pr4je pr4tk
 pr4rl bz5ah.

KFUH while at Penrhyn Island, Tahiti.

1emp 1bes 1pl 1anq 1yb 1zi 1ck tawe 2ta 2mm
 2xaf 2epa 2evj 2blm 2ahm 2bk 2exl 2ann 2aim 2cjj 3ckg
 3aao 3lv 3bva 3hg 3ack 4do 4si 4io 4tv 4rl 4oa 4fg
 4rm 4bu 4eu 4ll 4e0 4s0 4id 5oq 5w1 5uw 5uk 5zai
 5sd 5akn 5ox 5bg 5he 5va 5wi 5amw 5adz 5nq 5aj
 5aau 5aab 5agn 5atv 5amk 5afn 5alf 5akz 5ft 6awt
 6ih 6dof 6zak 6ef 6zd 6xad 6ih 6fv 6efe 6aiv 6aak 6ea
 6che 6ac 6zk 6am 6ahp 6oi 6bvs 6si 6cmh 6zmn 6te
 6hjp 6cm2 6cto 6buc 6abr 6zjh 6csw 6chs 6ct 6vr
 6hjj 6bmw 6fa 6km 6abg 6ajj 6cix 6cnc 6bgv 6btm
 6ap 6dah 6bgb 6apf 6af 6bil 6cvc 6oor 6afg 6aum
 6nx 6ase 6ajm 6qu 6ess 6dab 6wt 6eah 6ih 6ake
 6dam 6rw 6aea 6ow 6zh 6cz 6alv 6aaf 6tq 6ec 6dax
 6ake 6cgv 6cqa 6ev 6cmd 6cft 6bjd 6cl 6bhk 6bbv
 6bon 7de 7ek 7aek 7ly 7uz 7ay 7au 7to 7it 7nx 7df
 7uj 7ot 7eo 7es 8bce 8bnh 8car 8pl 8gz 8rv 8ac 8eg

Saly 8cvi 8bf 8er 8tx 8es 8eq 8bau 8se 8pk 8xk
 8cau 9ded 9uq 9efy 9yav 9zt 9xn 9bht 9dvr 9ek
 9er 9eay 9eht 9bpy 9wo 9fj 9efa 9zk 9dpx 9eky 9ff 9bib
 9cvn 9cxx 9bwb 9dmj 9co 9ark 9eji 9cfy 9bwo 9drd
 9dwk 9zd 9akf 9cid 9eez 9aod. c5ba 5go 5bf 5hp
 5ef 4aa 4gt eaa 3kp 9ek mlaf mlb mlk mlx m9a
 z1ao z1ax z1xa z2ac z2ae z2bi z3am z3ao z4ag z4al z4as
 z4aa z4ar z4ak z5da z2lj z2gq z2hs z2cm a2lp a2bb
 a2xa a2jw a2sw a2bk a2tm a2yh a3ef a3lp a2bq
 a4cm a4an a5bg a5kn a5da a6ag rbal raf1 rbd2
 rde3 rpa2 rcb3 rfg4 rfb5 raa8 bzlab bzlab pilhr
 chleg q2mk j1aa g2ce g2nm. nrrl nas numm nivr
 nivr nqw nedj nkf nfm npp npp npp npp nve naj
 nsf najd nqg nqkl nqj nqj nivr nivr.

iIER Ing. Santangeli Mario, Via S. Eufemia No. 19, Milano, Italy.

1ap 1aw 1bay 1bdw 1bke 1bqk 1cal 1cjb 1coe 1gr
 ikmx 2ahm 2aih 2ajw 2apy 2bir 2bi 2bxj 2cel
 2cje 2cty 2gp 2mm 3bhv 3ckj 3dh 4cw 4we 5us 8amd
 8bgn 8bpl 8bww 1daa 8djj 8don 8es 8eq 8mc 8th
 9ejb 9ez 9mu bz1av rxt clac c3kp ntt.

aAE5, Segundo P.I. Acuna-Navarro, 4159-B.

Aires, Argentina, South America.

1cmx 2xa 2xaf 5aaa 6bdb 6hm 7aay 9abc 1ch
 rdb2 reas rfa3 rfb5 rfc8 rff9 rfg4 rga2 rka9 rpa2 rfb8
 bz1ab bz1ac bz1ad bz1af bz1an bz1ao bz1ap bz1at
 bz1av bz1ax bz1bd chleg ch2ld ch2rm ch9tc elbes
 elar mlb mlbh z1ao z1ax a2ac z2ae z2ak oa4l oa4z
 yfwx kor hufxl hu6bub fw gnp npp npp wqk wqo.
 yFWX. J. Henerson, San Eugenio 1156.

Montevideo, Uruguay.

1aao 1apy 1bgq 1ch 1ckp 2zv 3auv 3bhv 4tv 6cx
 8bpl 8gz NPUI bz1ab bz1ad bz1af bz1al bz1an bz1ab
 bz1ap bz1at bz1av bz1ax bz1b bz1bc bz1bd bz1ia
 bz1ib bz2ab bz2ae bz2te PB RGT ch2ld ch2rm
 ch2jj ilgw oa3e oa4l oa4z z1ao z1ax z2ac z2xa z4as
 nppcmm.

ch2LD. L. M. Desmaras, Casilla 50.

D-Santiago de Chile-S. A.

1aao 1aci 1are 1bhs 1ch 1ckp 1cmx 1er
 1pl 1se 2fp 2agq 2bee 2zk 2gy 3lv 4cu 4fc 4h 4i
 4iv 4jr 4rm 4tv 4we 5akn 5akx 5co 5ew 5he 5lg
 5nj 5nw 5oq 5ox 5uk 5ux 5va 5yd 5zai 6ajm 6akg
 6bid 6bur 6cgv 6dab 6hm 6nw 6uf 6vc 6vj 7rl 8adv
 8bnh 8bo 8cbl 8adk 9ado 9bm 9ef 9cvn 9abz 9ded
 9dky 9dn 9dqu 9egu 9eht 9eji 9ky 9xn 9zt 9aak
 rad8 rae2 rae5 raf1 raf4 raf2 raf9 raf2 raf6 raf7
 ras8 rbal rgb8 rbl7 rbml rcb8 rdb2 rde2 rde3 rdd7

Communications

The Publishers of QST assume no responsibility for statements made herein by correspondents



NAVY DEPARTMENT

Bureau of Engineering
Washington, D. C.

18 Dec., 1925.

Sir:

At the Fourth National Radio Conference, representatives of the Bureau of Engineering, Navy Department, made certain statements to the Amateur Committee to the effect that the Navy Department would cease handling traffic on the frequencies assigned to amateurs.

The Bureau of Engineering in confirmation of the statements made by its representatives desires to inform you that steps are being taken to modify the frequencies being used by Naval traffic stations in the amateur band.

The Bureau would appreciate if your organization would forward to it any future evidence to the effect that Naval Stations are handling traffic within the amateur bands.

The Bureau desires to point out, however, that the Naval Radio Research Laboratory at Bellevue, D. C., has heretofore carried on extensive experiments on high frequencies and that it has been through co-operation of the amateurs that we have been able to develop high frequency communication. We desire to continue these experiments with the amateurs and to this extent we think it desirable that the Naval Radio Research Laboratory use frequencies in the amateur band for this purpose.

We hope that the foregoing meets with your approval and we hereby authorize you to publish this letter in one or more of the amateur radio magazines, as it is our desire to cooperate to the fullest extent.

Very respectfully,
—John Halligan, Jr.,
Engineer-in-Chief, U. S. N.
Chief of Bureau.

Mr. Hiram Percy Maxim
Pres., American Radio Relay League,
Hartford, Connecticut.

DEPARTMENT OF COMMERCE

Office of the Secretary
Washington

Mr. Hiram P. Maxim,
American Radio Relay League,
Hartford, Conn.

My dear Mr. Maxim:—

It is always a pleasure to see you at the radio conferences and I was very glad that you were able to attend the one which has just adjourned. As you know, I have been especially interested in the amateur side of radio. There was no desire manifested in the conference for any interference with amateur operations. It is gratifying to know that the conference did nothing to interfere with the amateurs in the slightest degree. I thank you very much for your service as chairman of the amateur committee.

—Herbert Hoover,
Secretary of Commerce.

More Picture Transmission

Ogden, Utah
Nov. 3, 1925.

Editor, QST:

An article entitled, "Jenkins' Awards," appearing on page 21 of the October number of QST, has just been called to my attention. The principal part of this reads as follows:

"The judges in Mr. C. Francis Jenkins' contest for ideas for picture-telegraphy have awarded a prize of \$50 to Mr. G. J. Shadick, of Regina, Sask., Canada, for a suggestion made in the first 60-day period. Mr. Shadick's suggestion was a very simple one—he proposed that instead of the complicated and messy pen-and-ink arrangement used for reproducing, a piece of carbon paper be wrapped around the white paper and a plain metal stylus be used for writing. Certainly a very simple suggestion and a very easy way to earn \$50.00. But no one had thought of it before, and that is the purpose of the contest—to bring forth ideas that have not occurred to the laboratorians working on this development. "It should be noted that the suggestions must be new and original suggestions."

I am enclosing an article from the *Electrical Experimenter* now called *Science and Invention* of December, 1917. In the first column of the second page of the article you will find described the use of carbon paper for the reception of telegraphed pictures, and in italics it states that the pictures illustrating the article were received in that way. The following paragraph in the article explains my reasons for having discarded "the complicated and

messy pen-and-ink arrangement" eight years before it "occurred to the laboratorians" that you refer to. Carbon paper reception was also explained in an article, "How to Make a Machine For Telegraphing Pictures," which appeared in the September and October, 1919, issues of *Electrical Experimenter*. Carbon paper for receiving was used on small experimental machines that my company sold to amateurs as early as 1918 for \$15.00 a set. This set was advertised for some time in the *Electrical Experimenter*, and I am enclosing a page from the December, 1918, issue showing one of the ads. This set was written up on page 322 of *Popular Mechanics* for September, 1918. Other articles on my work in telephotography appeared in many other magazines at about that time. The use of carbon paper for receiving telegraphed pictures was included in a patent application filed in 1917. Since then, many improvements in the methods and mechanism for using it have been made, and are, in connection with other developments, the subjects of patents pending. Carbon paper for receiving has been in constant use ever since 1917. I am mentioning the wide use and publicity that this method has received to show that the method can hardly be called "new and original" in 1925.

Now that a prize has been awarded for the new discovery of a method of mine clearly described eight years ago, and since your magazine says, "no one had thought of it before," I think I would be foolish not to raise a protest. I am enclosing plenty of data to prove my case, and I ask that you correct the wrong impression that your magazine has given by publishing this letter in the next edition that goes to press, and I think that it is entitled to a position equally as conspicuous as the article that it corrects.

I appreciate the fact that the judges in Mr. Jenkins' contest recognize my method as a superior plan for receiving, and I want full credit for the invention eight years ahead of those now working in this field. I think that before awarding other prizes in this contest, the judges and the "laboratorians" would do well to familiarize themselves with what has already been accomplished in telephotography.

It may interest the members of the A.R. R.L. to know that we will soon again put on the market the set of picture transmission machines that we sold in 1918, with the carbon paper method of reception, but with many improvements and refinements that I have developed since then, and the price will be very little higher than for the 1918 set. These machines will transmit regular half-tone pictures by radio or wire, and are especially designed for experimenters.

Inasmuch as I am of course interested in progress in telephotography, I, too, will offer a prize. Unlike the contest that has brought an award for the invention in 1925 of my carbon paper method of reception which has been in use since 1917, the entrants in my contest will not be supposed to have ideas that are new and original. They may use any system whatever, regardless of who the inventor may be. This contest will have as its purpose the encouragement of progress toward tele-vision, or the transmission of moving pictures. Realizing the difficulties involved, the prize will not be offered for its accomplishment, but merely for the speedy transmission of a still picture, without which it is useless to attempt the sending of movies. A practical system of transmitting movies must of course be capable of reproducing sufficient detail to retain the likenesses of at least four persons, full length, on the screen at once. To obtain the illusion of motion, the present theatre projection machines throw sixteen or seventeen still pictures on the screen per second. I will give a five tube Air-istocrat Radio Receiver, complete with all batteries, tubes and a standard Utah loud-speaker to the first person who succeeds in reproducing by radio at a distance of one mile a half-tone photograph with the amount of detail above mentioned within a period of five seconds. Successful movies by radio would of course require a speed eighty times as great as this, so it will readily be seen that my prize is for a transmission that marks merely a slight progress toward tele-vision. This offer stands good for one year. Entrants should send in the picture transmitted, signed on the back by two witnesses and a notary public who has also seen the demonstration. The picture must be accompanied by an understandable explanation of the system used. The judges will be the editor of *QST*, myself and a third judge that we will agree upon. Entrants must be prepared to repeat the record transmission for an additional witness appointed by the judges, should they require it.

I shall appreciate a letter from you advising me in what number this correction will appear.

Telephotographically yours,
—LeRoy J. Leishman, Leishman
Telegraphed Picture Service, Inc.

Crystal Cutting

3335 33rd Avenue South,
Seattle, Washington.

Editor, *QST*:

Referring to the article "Crystal Control for Amateur Transmitters" in the November issue of *QST*, there are a few points on which it might be well to enlighten the fel-

lows who "grind their own," before the number of nervous wrecks and broken crystals increases.

First, the various grinding materials in powder or grain form, which can be obtained at hardware or shop supply stores are rated according to the fineness of mesh of the screen they will sift through. For instance, No. 100 grade carborundum grains will pass through a 110 mesh but not through an 80 mesh screen, and so on. For sawing quartz crystals, carborundum is infinitely better than emery or aloxite. No. 100 grade is as good as any for sawing, while it is good to have several finer grades on hand for the grinding. If the final grinding is done with No. 220 carborundum grains, it will be much easier to polish the crystal afterwards.

Returning to the sawing of the crystal, most amateurs have a fractional horsepower motor around the station and enough mechanical ingenuity to rig up what a lapidary calls a "muck saw." This is nothing more than a steel or copper disc, motor driven, which carries the grinding material onto the crystal and grinds a groove or saw cut through it. This disc may be a piece of transformer steel about four to six inches in diameter, mounted on a shaft and rotated about 400 R.P.M. A small pan containing the grinding solution or paste should be located so the wheel will drip into it when it rotates. The crystal is held against the edge of the wheel.

If water and carborundum grains alone are used for grinding, trouble will likely occur when one tries to make the stuff stay on the wheel. The wheel or disc will squeak, get hot, and wear down fast if this is the case. If some ordinary clay is mixed with the carborundum and water it will help immensely, as this causes the "muck" to adhere to the wheel better. When you get it cutting good it is possible to cut through a quartz crystal an inch in diameter in about a half an hour. Be sure and keep the crystal cool, using plenty of water, or it will crack and check. This will ruin it for oscillating purposes, of course.

After sawing out a slice for a crystal, the corners can be taken off the crystal blank with an ordinary *carborundum* wheel, using plenty of water so that the wheel will not gum up, and keeping the crystal cool.

The final polishing of the crystal can be done after the manner described in *QST*, using tin oxide as the abrasive. You can get enough of this material at a prescription pharmacy for two bits to polish crystals for the whole A.R.R.L. It is not necessary to use a steel plate for the grinding and polishing; a piece of plate glass out of an old windshield will do just as well. Use a different piece of glass for polishing than for grinding or the scratches will never come out of the crystal. If you do not want to

tackle the job of sawing the crystal yourself, take it to a lapidary who has a diamond saw. This is a disc set with diamond grains and will cut quartz as if it were iron or some similar material.

—Howard F. Mason, 7BU,
Seattle Radio Laboratory

Our Army Affiliation

War Department,
Office of the Chief Signal Officer,
Washington, Dec. 23, 1925.

Editor, *QST*:

I am much interested in the first editorial in the December number of *QST*, entitled "The Army A.R.R.L. Affiliation", and I wish to thank you for your interest in the matter.

I am of the opinion that this affiliation will be of benefit to the amateurs of the country and also to the Army. This is another case where our Army can render a valuable service to the people of this country, and I am grateful to you for bringing it to their notice.

Yours very truly,

—C. McK. Saltzman,
Major General,

Chief Signal Officer of the Army.

You Need This ADVANCE "SYNC" RECTIFIER

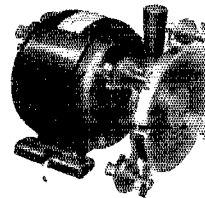

for Farther
and Smoother
Transmission!

(Ask other A. R. R. L. Men)

Thousands in the American Radio Relay League have improved their transmission with the new Advance "Sync" Rectifier. Gives clearer tone and better volume. Rectifies alternating current at 500 to 3000 volts to direct current for the plates of your transmitting tubes. Puts more energy into the antenna and counterpoise on account of actual copper-to-copper contact in rectification. Very efficient on short waves. Requires no attention—always ready. More in use than any other rectifier made.

Revolving disk is moulded bakelite six inches in diameter. Nickel plated brush holders with adjustable gauze copper brush support and brush holders perfectly insulated.

Price For rectifying wheel with complete brush assembly and mounting ring to fit your own synchronous motor. (Note: \$15.00 Motor must be 1/2 H.P., with 1/2 in. shaft and 1800 R.P.M.)

Rectifier with Westinghouse 1/2 h. p. Synchronous Motor — \$40.

We Pay All Transportation Charges in U. S. A.

ADVANCE ELECTRIC COMPANY
1260-1262 West Second St., Los Angeles, Calif.

ASK ANY RADIO ENGINEER

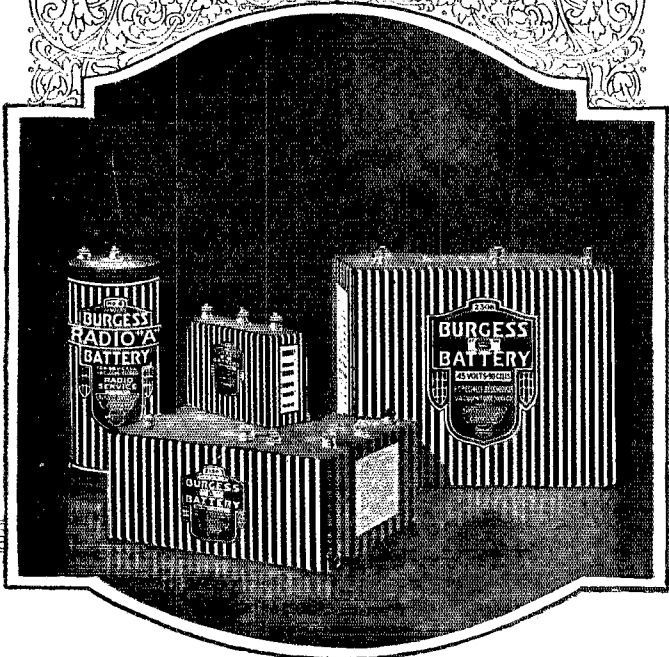

Contributors to your radio entertainment

VERY probably hidden away in the cabinet of your receiving set, the batteries you use are nevertheless surrendering their power unseen and unheard.

And to be able to contribute their energy and to add to the complete efficiency of your receiving equipment, those batteries must combine every desirable factor and formula known in the electro-chemical field.

Such Batteries are Burgess—products of the Burgess Laboratories—products which have been used by practically every famous explorer, the majority of amateurs and the leading radio engineers.

That's why when you use Burgess Radio 'A,' 'B' and 'C' Batteries you are using batteries which assure the utmost dependability, longer life and complete satisfaction.

BURGESS BATTERY COMPANY

GENERAL SALES OFFICE: CHICAGO

Canadian Factories and Offices: Niagara Falls and Winnipeg

BURGESS RADIO BATTERIES

SAY YOU SAW IT IN QST—IT IDENTIFIES YOU AND HELPS QST

If you want your signals heard--

Send With The Improved Martin

VIBROPLEX

Semi-Automatic Transmitter

For
Continental
or Morse
Code



Reg. Trade Marks
Vibroplex
Bug
Lightning Bug

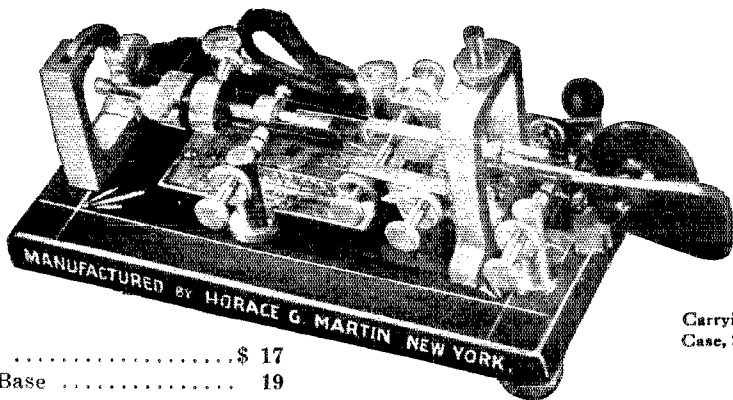

Carrying
Case, \$3

Japanned Base \$ 17
Nickel-Plated Base 19

It Makes Sending Easy

No operator—no matter how skilled can send Continental or Morse code on an ordinary key with the EASE and PERFECTION of the Vibroplex.

Dots are made automatically—five being made as easily as one, and without effort on the part of the operator.

Signals that will be heard and easily read thousands of miles away are transmitted simply by pressing the lever—the Vibroplex does the rest.

A special model Vibroplex designed for use without a relay is now ready. This model is equipped with Specially Constructed Contact Points 3/16" in diameter to break high current.

Just what every wireless operator needs. Sent anywhere on receipt of price.

\$25

Experienced operators use the Vibroplex in preference to the key because the sending is more uniform, the signals easier to read and the effort of sending reduced to the minimum.

Every amateur and radio operator should send with the Vibroplex. A little practice enables you to send with the skill of an expert. Order your Vibroplex NOW! Sent anywhere on receipt of price. Money order or registered mail.

What Users Say

From Station 4UA
Dundee, Fla.

"I am a constant user of the Vibroplex, and my signals are always clear and readable at audibility R5 in England, France, Italy, Argentina and Alaska according to reports received on QSL cards. Have had many a compliment on my sending 'good fist' but I attribute it to my faithful Vibroplex."

From Station u2EV
New York City

"I wouldn't be without a Vibroplex. I use it continuously at my station and on ships at sea and results have been more than I anticipated. It's speed and accuracy is marvelous, and makes one's sending far more readable than when using the ordinary key. What a blessing it would be if all amateurs used the Vibroplex thereby improving those 'bum fists' you hear so much."

THE VIBROPLEX CO., Inc. 825 Broadway, NEW YORK

J. E. Albright, President

Telephones: Stuyvesant 6094, 4828, 4829

SAY YOU SAW IT IN QST—IT IDENTIFIES YOU AND HELPS QST

AMERTRAN

TRADE MARK REG. U. S. PAT. OFF.

DE LUXE

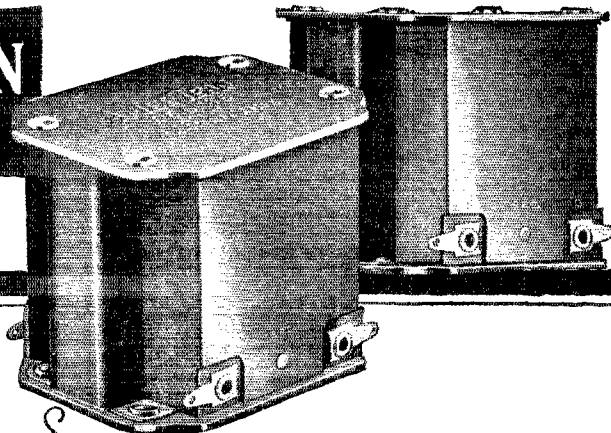

AMERTRAN
Types AF-7 and AF-6

AmerTran audio transformers Types AF-7 and AF-6 have been considered for years among the leaders in audio amplification. These popular and efficient models may now be purchased at a considerable saving in cost. Type AF-7 (ratio 3:1)—AF-6 (ratio 5:1) \$5.00 each

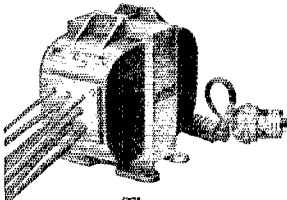

The
AMERTRAN Power Transformer

Type PF-41, 60 Hz-60 cycles 110 volts
Primary, 450—8-4-8-4 secondary

Type PF-45 is intended for use on the standard 110 volt, 60 cycle house lighting current. It has three separate well-insulated secondary windings. These are enclosed in a strong metal case provided with mounting feet. The secondary leads are standard code flexible wires left long enough to reach the terminals in the average set without splicing. This transformer is well suited for supplying AC power for filter circuits, and is designed with the usual margin of safety. \$15.00 each

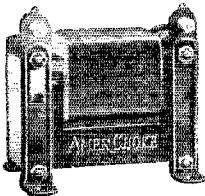

The New AMERCHOKE
Type 854

Type 854 is a scientifically designed impedance or choke coil of general utility, designed primarily for use in filter circuits. As an output impedance for by-passing direct current from the loudspeaker it is just as efficient and more economical than an output transformer. When used with a 1 mfd. (or greater) fixed condenser, the tone quality equals that of the best output transformer. DC saturation is prevented by two adjustable butt joints in the core. \$6.00 each

A New Standard of Excellence in Audio Amplification

THIS new audio transformer has been developed for those who are satisfied only with the utmost in quality. It possesses an unusually straight line frequency characteristic extending the range below the lowest note now being broadcast, and actually shows a gain of about three octaves below that previously obtained.

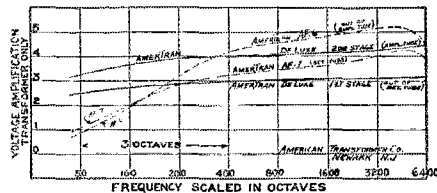

The AmerTran De Luxe is a transformer of moderate size and weight, enclosed in a strong metal case with mounting holes at both top and bottom so that it may be inverted, affording simplified connections. While the AmerTran De Luxe will improve any set, appreciation of its uniform amplifying qualities can best be realized when operated in conjunction with straight line frequency loudspeakers, such as the best cone and disc types, and with a tube in the last stage capable of handling the output.

The AmerTran De Luxe is made in two types, one for the first stage and one for the second stage, and plainly marked as such. The chief difference between these two types is that the first stage transformer has approximately 50% greater primary inductance than the second stage transformer, thus more nearly corresponding to the operating impedances of the tubes out of which they work. For this reason it is advisable to purchase and operate these transformers by the pair!

PRICE, EITHER TYPE, \$10.00

Write for descriptive booklet on AMERTRAN Radio Products

American Transformer Company

178 Emmet Street, Newark, N. J.

"Transformer builders for over twenty-four years"

SOLD ONLY AT
AUTHORIZED AMERTRAN DEALERS

Send for this RADIO BOOK FREE

The World's Largest Exclusive Radio Mail Order House Will Send You This Wonderful Book FREE

64 illustrated pages containing thousands of bargains in radio sets, semi-finished sets and radio kits of all styles, sizes and approved circuits. **5-tube sets as low as \$29.50.** Beautiful models of the very latest designs and types. Elaborate console models with loudspeakers built right in cabinets of genuine mahogany and walnut. **All sets guaranteed.** Coast to coast receiving range. Also contains everything in radio supplies, including batteries, chargers, loud speakers, transformers, condensers, rheostats and any other parts you may want for improving your set or building a new one. Guaranteed saving to you of $\frac{1}{3}$ to $\frac{1}{2}$.



1926 Catalog of RADIO BARGAINS Save $\frac{1}{3}$ to $\frac{1}{2}$

AMERICAN RADYNOLA 5 TUBE SET

\$29.50

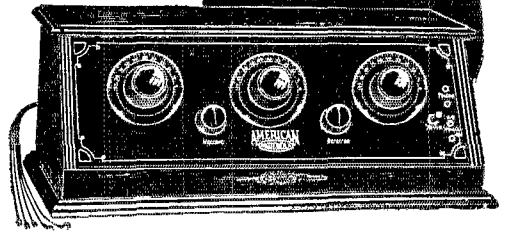

The Biggest 5-Tube Value on the Market

Positively the world's greatest 5-tube radio bargains. **Regular \$75.00 value.** Our large quantity production enables us to sell this set for **only \$29.50**, fully built and wired in beautiful mahogany cabinet of latest design with sloping Bakelite panel of Satin finish, handsomely etched and engraved as illustrated. Constructed of the finest low-loss condensers, coils and sockets. Bakelite baseboard panel and dials. **Price for set only. \$29.50** Transportation charges extra, shipping weight 25 lbs.

This set with all accessories, including the famous **American Bell loud speaker** with adjustable unit, 2-45 volt "B" batteries, one guaranteed 100 Ampere Hour storage "A" battery, cable for battery connection, 5-201A tubes, Aerial and ground equipment, and everything complete ready to set up and operate. Nothing else to buy. **Price \$59.75** Transportation charges extra. Shipping weight 100 lbs.

Order Direct from This Page! Save About One-Half!

Order direct from this page. Save $\frac{1}{4}$ to $\frac{1}{2}$. Our guarantee protects you. Money cheerfully refunded if you are not satisfied. Write your order and prices plainly. Send post office money order or bank draft for full amount to insure safety. Refer to any bank or commercial agency regarding our reliability.

SEMI-FINISHED 5-TUBE RADIO FREQUENCY SET

\$18.75

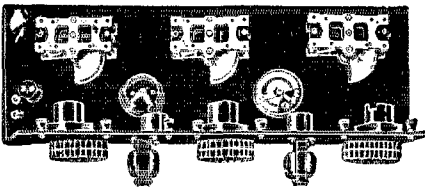

This special offer is astounding the radio world. **Coast to coast reception on loud speaker.** Low loss condensers and sockets. Highest quality transformers. Bakelite rheostats. All wiring concealed under Bakelite baseboard. 7x18 panel—fits into any standard 12" x 18" cabinet. Complete instructions for wiring. **Guaranteed saving to you of \$30.00.** Price of set all mounted, \$12.75. Cabinet of same model as American Radynola pictured above \$5.65 extra.

You must have our catalog no matter what set or kit you want. Our line is complete and includes all popular sets, such as Superheterodyne, Neutrodyne, Ultradyne, Reinartz, Regenerative, Radio Frequency, Browning-Drake, Super-Heterodyne Reflex and all other latest circuits. Kits, sets and parts manufactured by all well known manufacturers such as Frost, Howard, Baldwin, Brandes, Western Electric, Columbia and others.

Our semi-finished sets come with all parts mounted on panel and baseboard ready for wiring. Do not fail to send for our catalog. Remember—we are the largest exclusive radio mail order dealers in the world and carry the best of everything in radio. We save you $\frac{1}{3}$ to $\frac{1}{4}$ on the following kits. Detailed descriptions appear in our catalog.

SEMI-FINISHED 8-TUBE SUPER-HETERODYNE

\$43.75

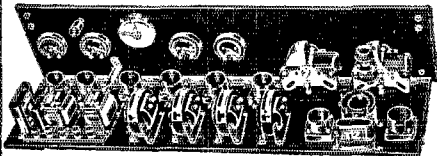

World's Famous 8-tube superheterodyne. Fully mounted on panel and baseboard. Comes **completely assembled** ready to wire and operate. We have testimonials from thousands of builders of this set. Some have received foreign stations on loop aerial. Unsurpassed in volume and tone quality. Low-loss straight line frequency condensers, vernier dials, finest quality rheostats. Matched Columbia long waved transformers. Requires only three screws for attaching panel and baseboard and set is ready to operate. 7x30 panel. **Price of set only \$43.75.**

Requires following accessories to complete this set: 7x30 cabinet, 8-201A tubes for storage battery operation or No. 199 tubes for dry cell operation. 100 Ampere hour storage battery, 2-45V "B" batteries, loud speaker, center tapped loop aerial. All these items are listed in our catalog at a tremendous saving.

Complete Parts for Best 45 Kilocycle Super-Heterodyne Genuine Remler Parts \$49.50

Catalog includes list of broadcasting stations, general radio information and facts about our free service division. Write for it today.

NEUTRODYNE
Genuine licensed Neutrodyne kit of parts, come fully assembled on the panel and baseboard with complete instructions, ready to wire. Price, **\$29.75**

COCKADAY
3-tube Cockaday kit of parts, fully assembled on panel and baseboard, ready to wire. Price, **\$15.85**

LOW LOSS SHORT WAVE
3-tubeset—25 to 100 meters. Fully assembled on panel and baseboard, ready to wire. Price, **\$19.80**

HARKNESS
2-tube reflex kit of parts, fully assembled on panel and baseboard, ready to wire. Complete instructions. Price, **\$16.95**

RANDOLPH RADIO CORPORATION
159 N. Union Ave. Dept. 251 Chicago, Illinois

POWEL CROSLLEY

JR.

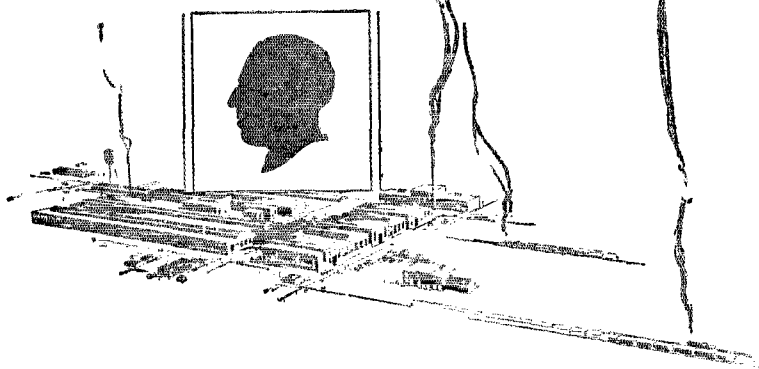

INDUSTRIALIST *Pioneer Radio Builder*

At a time when products of his manufacturing genius were already known to millions, Powel Crosley, Jr., boldly diverted his energies to the development of radio reception, then scarcely known beyond the laboratory walls.

Pioneering both in engineering trends and manufacturing practices, Mr. Crosley has been a vital factor in making radio and broadcasting as much a part of American life as motion pictures and the motor car.

There is scarcely a milestone in the development of popular radio on which his shadow has not been the first to fall. And his announcement of December 26th concerned a milestone that dwarfed all others in its importance — *four entirely new radio receiving sets:*

The Crosley 4-29 (4-tube)	\$29.00
The Crosley 5-38 (5-tube)	38.00
The Crosley R.F.L.-60 (5-tube)	60.00
The Crosley R.F.L.-75 (5-tube)	75.00

These are now being demonstrated by Crosley dealers and will be completely described in a forthcoming issue.



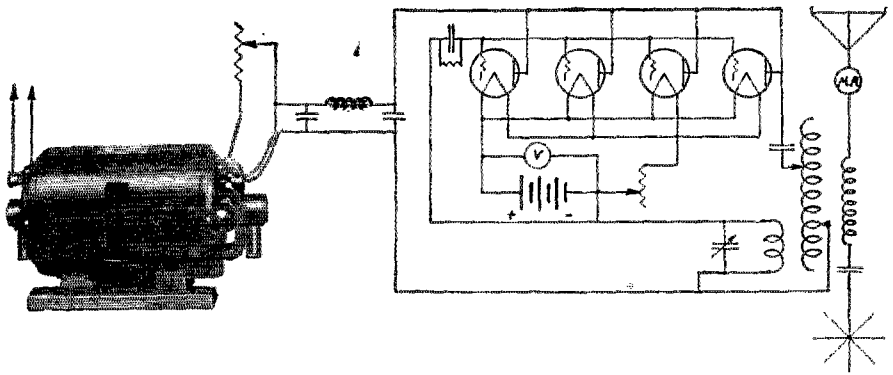

This is Item No 8 furnishing Power Supply for 4/5 watters in the reversed feed back hook up.

Item 8 can be furnished with either AC or D C. motors, or as a separate generator. The machine is two bearing, wick oil, and its output is conservatively rated at 500 volts, 150 watts. It's a real little maximum miles per watt DX getter.

ELECTRIC SPECIALTY COMPANY

Manufacturers of Motors, Generators, Motor-Generator Sets, Dynamotors and Rotary Convertors for all radio purposes. Have you got your copy of Bulletin 237B and ESCO Filter Facts? If not write for them.

TRADE "ESCO" MARK

275 South Street

Stamford, Conn.

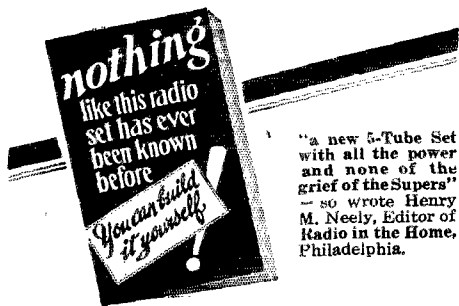

"a new 5-Tube Set with all the power and none of the grief of the Supers," — so wrote Henry M. Neely, Editor of Radio in the Home, Philadelphia.

Get This Book

Write today for this big fascinating 32-page booklet which tells how you can build the truly amazing new QUADRAFORMER receiver. Based on a new radio principle, five tubes give remarkable results.

Enclose 10c and you'll have it by return mail

Gearhart-Schlueter Radio Corp'n
718 Voorman Avenue, Fresno, California

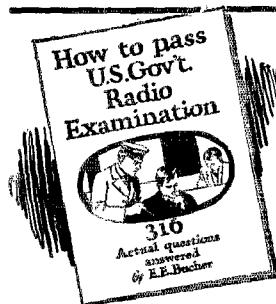

60c

For a Short Time Only

RADIO INSTITUTE OF AMERICA
326A Broadway New York City

PASS the U.S. Government Commercial or Amateur Radio License examination! This book will help you do it! Send sixtycents in stamps or coin for your copy — postage prepaid to any point in the U. S., Canada or Mexico.

NEW

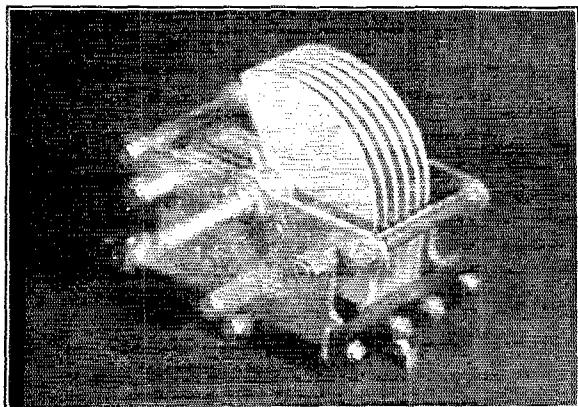

A Radically NEW Type of Condenser Design which Gives a Straight Frequency Tuning Curve and Will Not Change Its Calibration

When a demand arose for a condenser with a Straight Frequency tuning curve, Cardwell went at the job from a less obvious but far more practical direction than other manufacturers. They shaped the plates to secure a straight frequency line and the result was either a very bulky condenser or one with flimsy plates and weak over-balanced construction, and with which permanent logging was impossible. Cardwell shaped the dielectric.

The new Cardwell utilizes plates tapering from more than $\frac{1}{2}$ " thickness at one end to about double the thickness of an ordinary plate at the other. As the plates are meshed, the spacing becomes smaller, giving a regularly increasing ratio of capacity change per degree of dial movement.

Owing to the very heavy construction of the plates, they can not bend, warp, or otherwise change their

alignment, and therefore, a given calibration will be permanent. For wavemeter purposes, these condensers are ideal.

The new condenser is exactly the same size as the original Cardwell. With plates wide open it will mount behind a 4" dial and extends less than 3" back from the panel. It can be substituted for Cardwell type "B" and "C" condensers without disturbing panel holes, other instruments, or connections.



All sizes are manufactured, from 75 micro-microfarads up.

PRICE: 150 mmfds - - \$4.00; 250 mmfds - - \$4.25

See Also Announcement on Page 88

CARDWELL

81 Prospect Street

Brooklyn, N. Y.

"THE STANDARD OF COMPARISON"

This book, written for the U. S. Navy, first appeared in 1907, the author being Lieutenant (now Admiral in command of the U. S. Fleet) S. S. Robison, U. S. Navy. This edition has been revised and brought up to date by Commander S. C. Hooper, U. S. Navy, Radio Officer of the U. S. Fleet during the past year. A review of this book appeared in the December issue of QST, in which it was stated this is perhaps

“The Best Radio Book That Ever Came To This Desk”

The review was as follows:
“The famous ‘manual’ has, in its 6th edition, risen to entirely new heights. This last edition ranks with the very best of all published radio matter and adds to its usefulness the excellent printing and binding that has marked the earlier issues.

Never have we seen a book that so well followed out the plan of starting with simple theory but always keeping in mind that the reader was interested in the application of the theory, and cared nothing about the theory itself. Therefore the text progresses rapidly to the actual apparatus and discusses the modern types clearly, rapidly and usefully.

This book is so universal that it deserves unusual treatment and shall have it—here are the chapter headings in full.

- 1—General Theory
- 2—Elementary theory of electricity
- 3—A.C. Theory
- 4—A.C. Theory applied to radio
- 5—Damped oscillations

- 6—Wave propagation
- 7—Radio Instruments
- 8—Radio Transmission
- 9—Radio Reception
- 10—Theory of vacuum tubes
- 11—Vacuum-tube transmitters
- Part 2—Practical application of apparatus and measurements
 - 1—Practical application of apparatus
 - 2—Radio measurements
- Part 3—Useful Information
 - 1—Tables and formulas
 - 2—Mathematics (Arithmetic, Algebra, Geometry, Trigonometry)
 - 3—Radio Laws
 - 4—Miscellaneous
- Part 4—Index

That is a tremendous territory to cover in a single volume, and it takes almost 900 pages to do the job. However, the job is done and the result is a book that is not only worth \$3 which it costs but is perhaps the best radio book that ever came to this desk.”

PRICE, \$3.00 POSTPAID

Send checks or money orders to Secretary-Treasurer, U. S. NAVAL INSTITUTE, ANNAPOLIS, MARYLAND, U. S. A.

Special Offer:

Send \$2.00 additional and the “Storage Battery Manual, Including Principles of Storage Battery and Design, 1920,” by Lieut.-Comdr. L. C. Dunn, U. S. Navy, will be sent postpaid. This book of 391 pages recently sold for \$7.00.

CARTER
New “IMP” Rheostat

All Resistances—3 to 50 Ohms



(Pat. Pend.)

\$1.00. Half Size

(Complete with Knob)

Smallest rheostat made, yet most efficient. A Carter designed contact arm that assures positive, even contact. No jerking or noises. One hole mounting. Potentiometer same size.

Any dealer can supply

In Canada—Carter Radio Co., Limited, Toronto



LOW REL LOSS

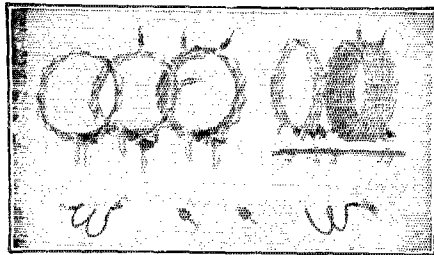

Plug-In Coils

Stations That Use and Recommend “REL” Low Loss Plug-in Coils

Grosse Pointe Farms,
November 19th, 1923.

Gentlemen:—

I have tried out the all-wave short wave coil set you had made up for me, and I think it is very good. Anyway, it is the best thing that I have had. I would like very much if you would make me a duplicate—exactly like the last—and ship it to me with all the coils, also another set complete, of the all wave coils, immediately.

Very truly yours,

Henry B. Joy, Radio Station 81 A.

Experience proves best results with REL Low Loss Plug-in Coils—Tune in from 10 to 110 meters with the five interchangeable units—Connect them in any low loss wave circuit and watch the performance!

Price per outfit, \$4.50, including mounting
(At your dealer, or order direct)

RADIO ENGINEERING LABORATORIES
27 Thames Street, New York, N. Y.
“Low Loss Coil Pioneers”

Announcing a New Product!

Designed for Reliable
Long Distance Communication

on

1 Meter to 200 Meters



INPUT RATING 150 WATTS

Plate Voltages 500-3000

Plate Currents 40-50 MA.

Fil. Voltage 10

Fil. Current 2.35A



*Sold and Shipped Direct
Upon Receipt of Money Order*

Price, \$18.00
Parcel Post Prepaid

DE FOREST

TYPE-H

TRANSMITTING TUBE

DE FOREST RADIO. CO., 120 Sherman Ave., Jersey City, N. J.

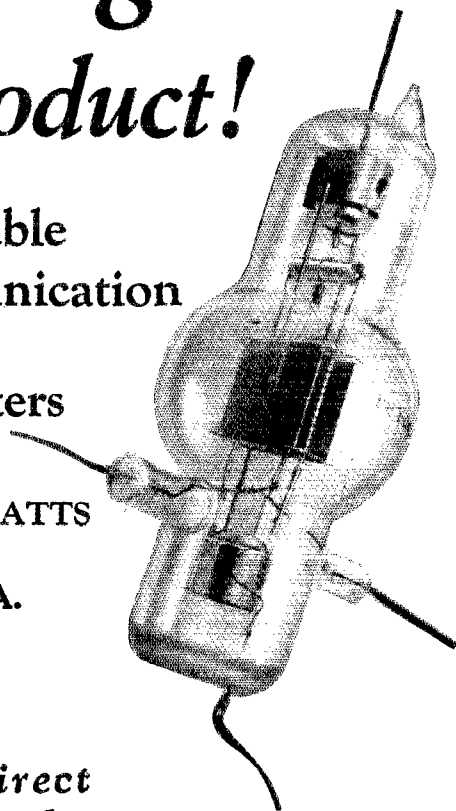



Accurate
and stay accurate

helps your DX record

LUCKY nights happen when a set built out of fence wire by rule of thumb can get DX. But the surest way to get the utmost in radio performance is to have all parts in correct electrical balance. Especially the fixed condensers, for they must release the incoming impulses at exactly the right time, or there is discord. This is where accuracy counts most.

The accuracy of Sangamo Mica Condensers is doubly assured. They are tested individually for accuracy, and guaranteed to be within 10 per cent of marked capacity. They are solidly molded in bakelite, absolutely impervious to any outside influence. There are no exposed edges. You can boil them, freeze them, expose them to acid fumes or heat the terminals with a soldering iron, but their capacity remains unchanged.

Sangamo Mica Condensers are made in all standard capacities, with or without resistor clips. They can be easily installed in any set, old or new.

Also available: Sangamo By-Pass Condenser 1 MFD. \$1.25. ½ MFD. .90



All progressive dealers have Sangamo Condensers in stock, or will quickly secure them if you insist.

Sangamo Electric Company

1421-7

Springfield, Illinois

RADIO DIVISION, 50 Church Street, New York

SALES OFFICES—PRINCIPAL CITIES

For Canada—Sangamo Electric Co. of Canada, Ltd., Toronto.
For Europe—British Sangamo Co., Ponders End, Middlesex, Eng.
For Far East—Ashida Engineering Co., Osaka, Japan

EAGLE



All That's Best in Radio

Eagle Owners have the satisfaction of knowing they have the best Radio Receiver made, regardless of cost.

Ask Your Dealer



EAGLE RADIO COMPANY

16 Boyden Place Newark, N. J.

RAJAH SOLDERLESS SNAP TERMINALS

Instantaneous in Operation—Positive Contact. For Panel, Ground and Battery Connections.



Patented—Sept. 23rd, 1924.

The Base Stud is tapped and furnished with 8-32 screw and washer. This fits all "B" Batteries with screw posts.

RAJAH
Ground
Connection

Used on
TUNGAR,
RECTIGON,
PHILCO and
EXIDE.

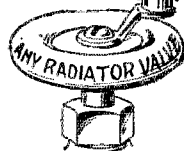

Terminal, complete, either style15c

Extra Base Studs5c

RAJAH AUTO SUPPLY COMPANY
Bloomfield, New Jersey

Build a Practical "B" Eliminator

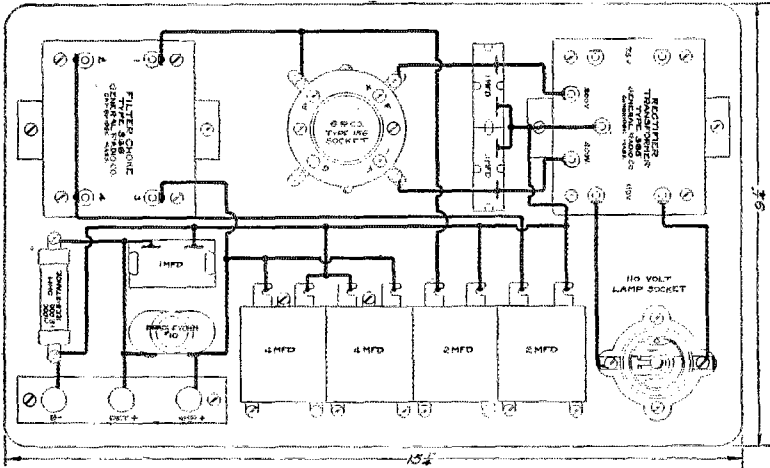

Wiring Diagram for "B" Eliminator

THE above diagram shows the arrangement of parts and connections for an efficient "B" battery eliminator using the new General Radio Type 365 Rectifier Transformer and Type 366 Filter Choke. These Transformers give very satisfactory results in a plate voltage supply unit when used with the new Raytheon rectifier tube or other tubes of similar characteristics.

For further description refer to page 9158 of our new Bulletin 923-Q or write for our circular, "Instructions for Building a "B" Eliminator."

GENERAL RADIO CO.
CAMBRIDGE 39, MASSACHUSETTS

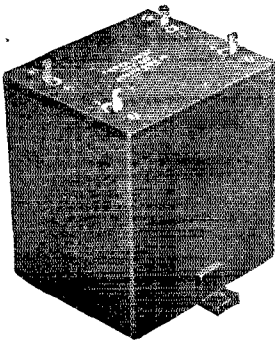

Type 366
FILTER
CHOKE

Price \$10.00

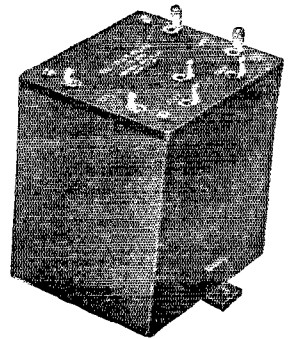

Type 365
Rectifier
Transformer

Price \$10.00

GENERAL RADIO

A BETTER AND DIFFERENT PLUG-IN COIL

Note its advantages listed below—and try and do without it!

1. Positive contact is secured through General Radio plugs and jacks.

2. With 3 Coils, continuous, gapless range is secured from 140 to 16 meters. One of the 20-40-80 meters amateur bands is located in the middle of the tuning range of each of the 3 coils. (For this a SFL Condenser, 140 mmfd. max. cap. is essential.)

3. Operation of regeneration condenser has no effect on the tuning; the 2 controls are completely independent.

4. Antenna coupling is adjustable; done by a primary coil Wave Stations, etc.

These coils are essential to the most efficient operation of your station. Order your TODAY.

and not through a condenser. Secondary coils are specially constructed so that setting of primary coil does not need to be changed when secondaries are exchanged.

5. Coils are space-wound solenoids on skeleton frames.

6. Both tickler and antenna coil are at filament end of the secondary.

7. These coils cover the 3 U. S. Amateur Bands, all European Amateur Bands, Short-Wave Broadcast, U. S. Naval and Commercial Short-

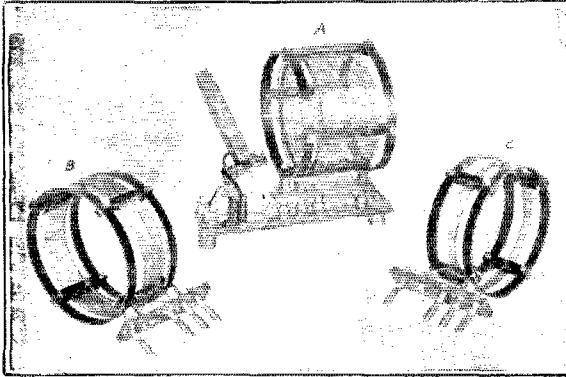

AERO PRODUCTS INCORPORATED, 1772 Wilson Avenue, Chicago, Illinois

S-M PARTS

LOW LOSS INDUCTANCES

All-bakelite, low loss, interchangeable coil for 50-500 meters. May be used as oscillators, antenna adapters and RF Transformers in standard circuits. Each 3 1/2" long with winding diameter of 2".

Price all types, 50 to 600 meters. Each\$2.50
Sockets for any size coils. Each\$1.00

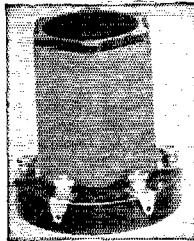

S L F CONDENSERS

S-M Condensers are particularly adapted for short wave reception because of their extremely low dielectric and eddy-current losses. They are the smallest SFL Condensers made. Supplied with special attachment for single control.

PRICES

No. 310 .0005 \$6.00
No. 311 .00035 5.75

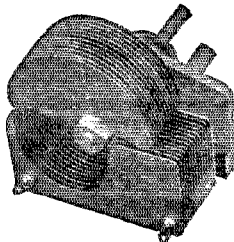

Improved Raytheon-Thordarson B-eliminator SMKit 650 includes all parts necessary, \$34. Building Instructions, 10c.

Send for circulars describing S-M Products

SILVER-MARSHALL, Inc.
104 WABASH AVE. CHICAGO

Faradon



Expert Amateurs Know Faradon Condensers

The importance of their dependable operating efficiency in his own transmitting set and in the operating equipment of the outstanding broadcasting stations is well known to him. The competent staff of the same progressive pioneer organization now produces an equally superior compact all-metal-mica condenser for receiving sets.

FARADON QUALITY

at the receiving end is secured by utilizing the MODEL T

If your dealer has not the Model T on hand advise us. An informative circular will be sent if you mention QST.

Wireless Specialty Apparatus Co.
JAMAICA PLAIN, BOSTON, MASS., U. S. A.
ELECTROSTATIC CONDENSERS FOR ALL PURPOSES



Did You Get—

The Circular and Log Sheet
which we sent to you giving
detail of our Amateur contest
“More Miles Per Watt”

?

¶ Long before the days of popular Broadcast Radio it was our good fortune to have worked with the amateurs and furnished them with instruments to meet their problems.

Send for new 15-C catalog of Radio Instruments, just off the press.

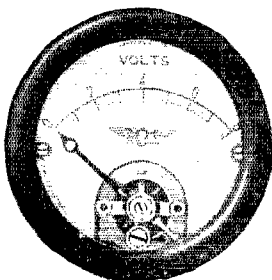

If you are building a receiving set for yourself send for circular 776 showing our 2 inch line of instruments

Jewell Electrical Instrument Co.

1650 Walnut St.

Chicago

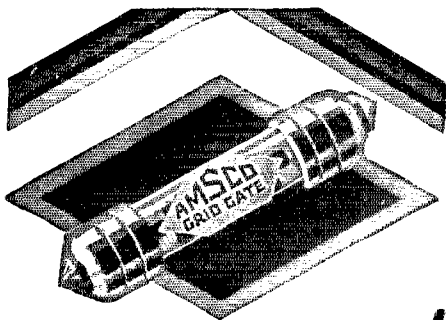

Amsco's Newest!

**Grid Gates, Resistors
and Resistance Couplers**

Grid Gates are the Amsco improvement on "leaks." They provide *measured and exact control* of the current flow. Extra large for noiseless service. Fit all mountings. Insist upon Amsco Grid Gates, Amsco Resistors, Amsco Resistance Couplers. The latter are made with .006 condenser in genuine Bakelite base with mountings for two Resistors.

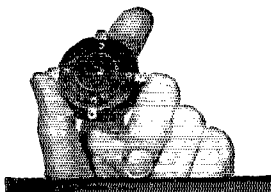

**The New Amsco
Universal Sockets**

Especially designed to fit all the new types and sizes of U. X. and C. X. radio tubes. Clicks into contact—making positive wipe connection. Most compact and fool-proof socket made. One hole mounting. The Ultimate Socket—will be 1926 standard. Ask your Dealer.

AMSCO PRODUCTS, Inc.
Broome and Lafayette Sts., N.Y.C.

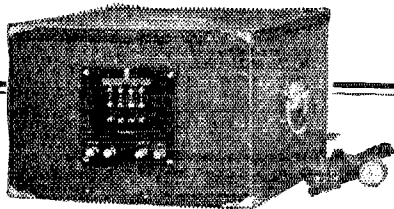
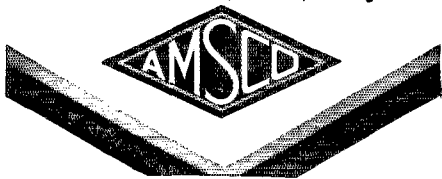

"B" BATTERY POWER
from your
HOUSE LIGHTING LINE
"B" Eliminator Simplicity

Guaranteed Two Years

Line hums are impossible. No costly bulbs or transformers are contained to burn out. No harmful acid—shipped ready for use. Units supplied for 110 volts A. C. or D. C. or farm lighting plants. Write for complete details! Distributors! Everybody!

PRICE 90 Volts Type MX \$30.00
135 Volts Type MX \$40.00

KIMLEY ELECTRIC COMPANY, Inc.
2665 Main Street Buffalo, N. Y.

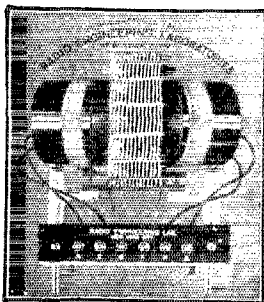

**LOPEZ
LOW
LOSS
TUNER**

NEW AND IMPROVED

With two tuning ranges and one condenser. Covers two sets of wave length bands 150 to 400 and 220 to 600 meters. Real DX reception. Extremely sharp.

Price \$10.00

At your dealer or direct from
RADIO ENGINEERING LABORATORIES
27 Thames Street, N. Y.

"The Low Loss Coil Pioneers"

**NO MORE LOOSE CONNECTIONS
X-L PUSH POST**

A Binding Post that really does excel, looks, action, service and convenience. Push it down—insert wire—cannot jar loose from vibration. No screwing or danger of shearing off wires. Furnished attractively plated with soldering lug and necessary markings.

Price Each, 15 Cents

X-L RADIO LABORATORIES
2428 Lincoln Ave., N. CHICAGO



The KARAS Orthometric

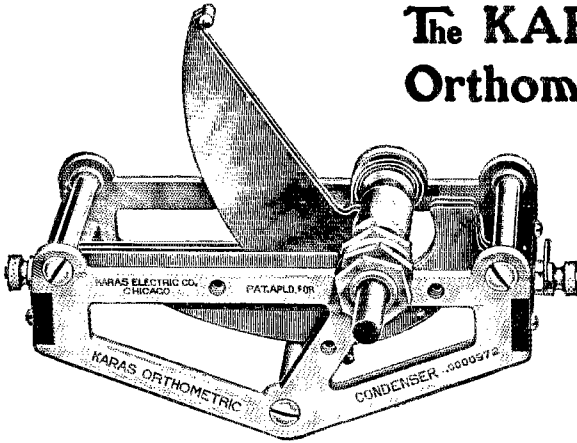

A 5 Plate Straight-Frequency-Line Condenser Designed Expressly for Amateur's Short Wave Work

*Built at the Suggestion of Lieut. F. H. Schnell,
Traffic Mgr., American Radio Relay League*

When Karas Orthometric Condensers for broadcast receivers were brought out, this question came to us from all sides, "Why do you give the Broadcast Listener the advantage of a really PRECISION Condenser, and not offer it for the infinitely more exacting short wave work of the Amateur?"

We were assured by Lieut. Schnell and others that there would be a big demand among Amateurs for this condenser in a proper size. Here it is! A Karas Orthometric Condenser built especially for you. 5 plates; Max. capacity .0000972; Min. capacity .0000096; Absolutely Straight-Frequency-Line by test. Losses so low that they have not yet been measured—yet theoretically out of the direct field; Extremely low resistance at all capacities. A beautiful job with nickle frame and brass plates that will delight the eye of the mechanical critic. Price \$6.50 each.

Order Through Dealer or, Direct on This Coupon

Due to the widely scattered Amateur demand, this model is not generally sold by our regular retail distributors. Orders will be filled direct at the price of \$6.50, or may be placed through your dealer and his jobber. If you order direct, use this coupon. Send no money. Just pay the postman the price plus a few cents postage.

KARAS ELECTRIC CO.
Factory 4040 N. Rockwell St.,
Office; 1072 Association Bldg.,
Chicago, Ill.

Karas Electric Co., 1072 Association Bldg., Chicago

Please send me.....Karas Orthometric Condensers, 5 plate size. I will pay the postman \$6.50 each plus a few cents postage upon delivery. It is understood that I have the privilege of returning these condensers for full refund any time within 30 days if they do not prove thoroughly satisfactory.

Name.....

Address.....

If you send cash with order, we'll ship condensers postpaid

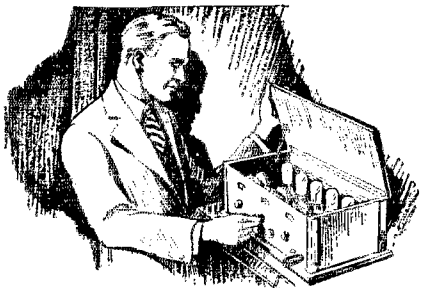

Inside of Almost Any Good Set—

If you'll lift up the cover of any good radio set and examine the controls closely, you are almost sure to find "Centralab" represented. And where you find Centralab controls, you have assurance of the best possible radio reception.

The Centralab Radiohm provides positive control of oscillation in radio frequency amplifiers when used in series with the plate or grid, or in shunt with the grid. Permits smooth, noiseless adjustment from approximately zero to the maximum of 2,000, 50,000, 100,000 or 200,000 ohms. Price, \$2.00.

The Centralab Modulator, used in audio circuits with any transformers or Thordarson Autoformers, provides noiseless adjustment of tone volume from a whisper to maximum, without de-tuning. A variable non-inductive resistance of 500,000 ohms. Price, \$2.00.

At your dealer's—or mailed direct. Write for literature describing these and other Centralab Controls.

Central Radio Laboratories
20 Keefe Ave., Milwaukee, Wis.

Centralab

The KODEL MICROPHONE Loud Speaker

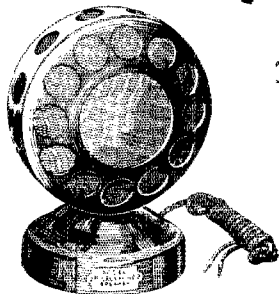

Two Models

\$15

\$20

THE loud speaker that has the whole country talking. An exact replica of the microphone used in broadcasting. Tremendous volume - - rich clear tone - - Handsomely finished in Roman Gold. At any radio dealer.

Write for descriptive literature

THE KODEL RADIO CORP.
508 E. Pearl St. Cincinnati, O.
Owners of Broadcasting Station WKRC

Another TOAZ Development FUSOCKETS

PATENT APP. FOR

Individually Fused Sockets

Insure your Tubes

199 or 200

Single or any multiple

At Your Dealers or

\$1.00 per Socket, P. P.

TOAZ TERMINALUGS BEST FOR RADIO BUGS

At your Dealers or send \$1.00 for Special Package, including Gripfast Terminalugs, (Pat. App. For.)

TOAZ Engineering & Sales Co.
11703 ROBERTSON AVE., CLEVELAND, O.

BUILD THE NEW FIVE TUBE

Hammarlund Roberts

RECEIVER

Send 25c for complete "How to Build It" Book
Hammarlund-Roberts 1182-P Broadway New York

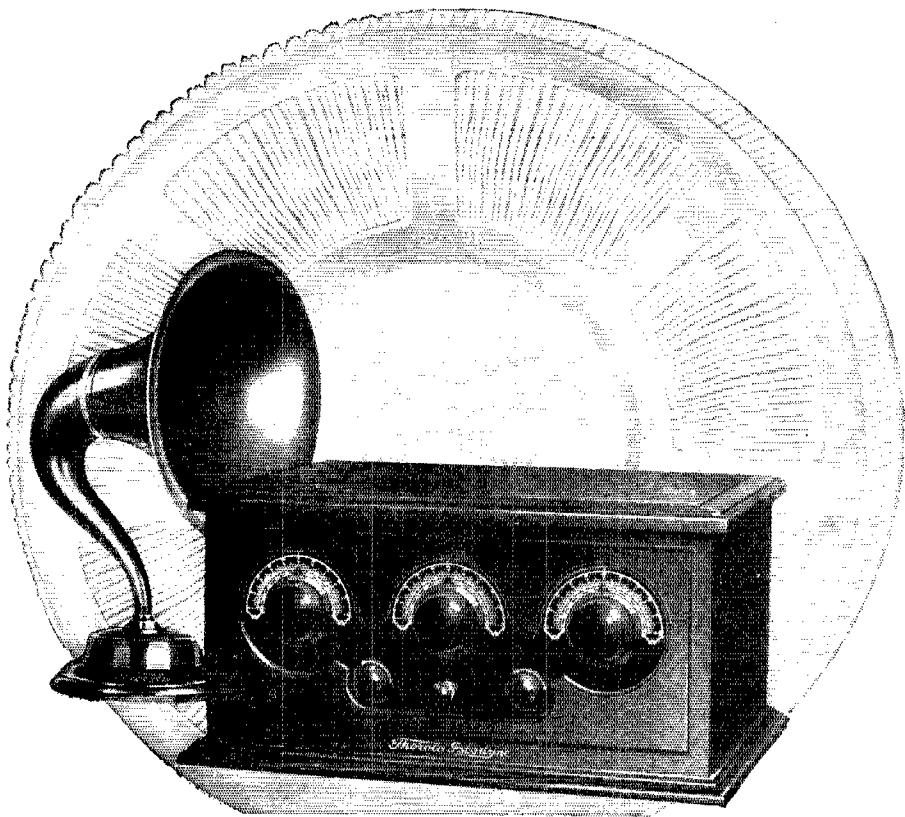

It *Must* Suit You Experts

Specify your own expert test of the Thorola Islodyne—the dealer will comply. Regardless of price comparisons, number of tubes, or style of circuit, Thorola must be best by every standard in your most expert judgment.

Even you have not known performance such as Thorola Islodyne regularly yields. Not only the principle of Thorola Low-Loss Doughnut Coils,

but every phase of Thorola design and construction points real reasons for Thorola superiority to the most critical scientific investigator.

You know much about radio. That is why we value your verdict so highly. That is why every statement here is made most advisedly. You have very likely had any number of sets. Now hear Thorola and know what still lies ahead even for you.

REICHMANN COMPANY, 1725-39 W. 74th St., Chicago

Thorola

ISLODYNE

SAY YOU SAW IT IN QST—IT IDENTIFIES YOU AND HELPS QST

THE SUPER-SYNC

The Synchronous Rectifier That Can Be Filtered

The Super delivers a full wave rectified Alternating Current wave and when filtered delivers a pure un-wavering Direct current. On the low waves it is necessary that the plate voltage be steady as any change in the voltage changes the wave thus causing wavering tones making the signals hard to read.

The Super gives practically 100% rectification at

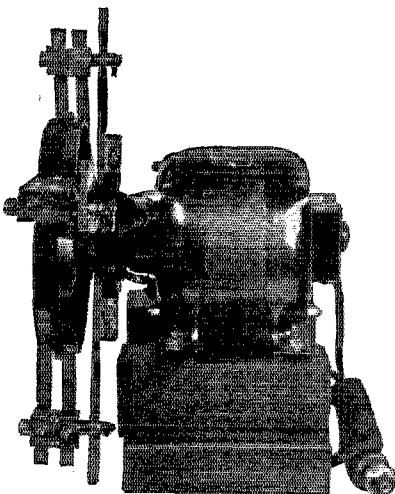

PAT. PENDING
PRICE \$75.00 F. O. B. ST. LOUIS

all times thus eliminating the trouble of other types of rectification. Another advantage of the Super is that it requires minimum space for installation.

The commutator on the Super is eight inches in diameter and is turned at a synchronous speed by a 1/4 H.P. motor made by the General Electric Co. This motor can be supplied for either 110 or 120 volts 50 or 60 Cy.

MARLO ELECTRIC CO., 5241 Botanical Ave., St. Louis, Mo.

New DX Help

—many users report fine overseas reception with this new Magnavox Tube. Its internal capacity is 4.5 m.m.f. Oscillates freely and easily at extreme low wave lengths without un-basing. Amplification constant very high with low impedance and super-sensitive for amateur short wave work. Price \$3

The Magnavox Company
Oakland, Cal.

MAGNAVOX

TUBES

Tipless — Non-microphonic

ARE YOU THE MAN ?

to be the first in your town to sell and demonstrate **POWEROLA**, the famous 5 tube **NO-BATTERY ELECTRIC LIGHT SOCKET RADIO RECEIVER** (not an attachment), universal for D.C. or A.C. (110-115 or 40-60 cycles), now sold and demonstrated thru **THE NEW YORK EDISON CO.**, public utility companies and radio, electric and music dealers everywhere. Absolutely dependable, fully guaranteed, powerful, practical, perfect in performance. Tested and endorsed by Popular Radio, Radio Broadcast, Radio News, and all leading Authorities and Engineers of your local electric light company.

Are you the Man Who Sees Opportunities
Ahead for Real Money Making?

Write for literature, terms and prices at once

You Too Can Make Powerola

Send \$1.00 for wiring diagrams showing how to rewire any old or new parts. Battery Sets, or Radio Circuits (1 to 8 Tubes) and power apparatus used to operate satisfactorily from A.C. or D.C. Get in at once on wonderful and exclusive business. Thousands of homes are waiting for you now.

POWEROLA RADIO CORP.
1845 Broadway Dept. QST N. Y. City

RADIO AGENTS WANTED

5 Tube Demonstrator FREE!

Earn \$25 to \$100 a week, part or full time. Everyone a prospect. Complete line standard sets and accessories, \$5 to \$90. Write today for illustrated catalog and exclusive selling plan for live dealers and community agents.

20TH CENTURY RADIO CO., 1141 Coca Cola Bldg., Kansas City, Mo.

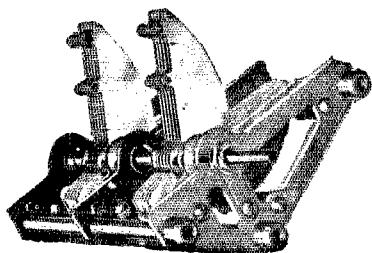

Made under Hogan Patent No. 1,014,002
Jan. 9, 1912

Simplified Tuning!

Dial crowding has been responsible for blurring radio reception. You can now get new pleasures from your radio. Just as each note on the piano has its tone, so each degree on the dial will have its station. U. S. Tool Straight line frequency condensers make this possible. These condensers spread the stations uniformly round the dial, each degree has its station and **one station only.**

The *NEW* U. S. TOOL STRAIGHT LINE FREQUENCY CONDENSERS

are the latest product of skilled engineers, designed and manufactured in a factory that for years has specialized in the making of precision instruments.

When you use the U. S. Tool S. L. F. Condenser you will know the real joys of radio performance.

Write for booklet

U. S. TOOL COMPANY, Inc.

Ampere

New Jersey

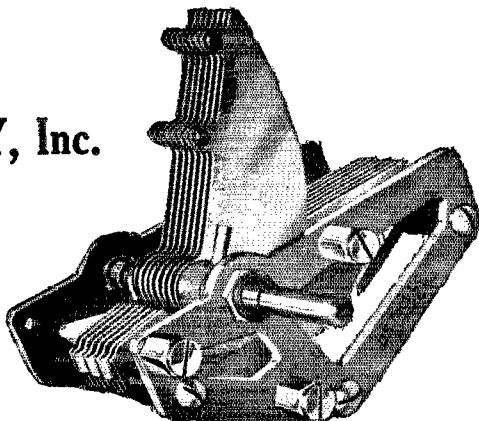

for Reliable Radio Transmission and Reception

Use
Hoyt

METERS

Hoyt Milliammeters and Voltmeters for your Radio transmitting and receiving sets are accurate at all readings, dependable and reasonable in price. They are made in all ranges ordinarily used and in sizes for both flush and panel mounting, from 2" up.

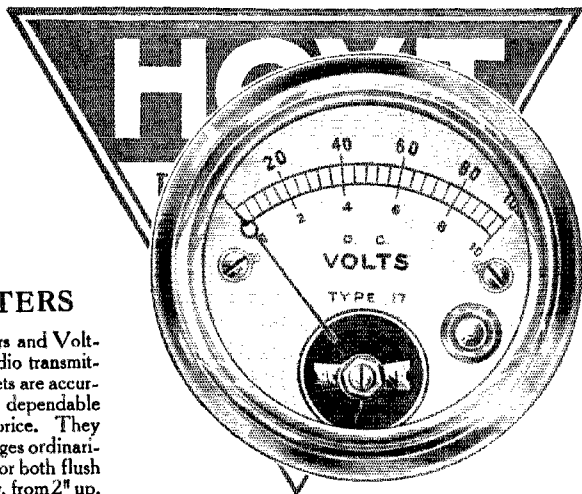

HOYT builds a full line of Radio Meters in all sizes and types. These are described in our book "Hoyt Meters for Radio." A request will bring it to you.

BURTON - ROGERS - COMPANY

26 Brighton Ave., Boston, Mass.

National Distributors

A Great Seller—A Good Buy

"RADIO THEORY AND OPERATING"

The New Radio Text Book By *Mary Texanna Loomis*

On the market only three months to Dec. 1st and numbers among its purchasers

The United States Government

960 Public, College and Gov't Libraries

27 Radio, Technical and High Schools

8 Large Wholesale Houses

105 Retail Book Stores and Radio Dealers

Also a Large Number of Commercial and Amateur Radio Operators and Fans.

It is undoubtedly the radio book of the day, right up to the minute and filling a long felt want. 850 pages; 670 illustrations; red kraft leather flexible binding.

Price \$3.50

If your dealer does not handle it send check or money order to

LOOMIS PUBLISHING COMPANY

405 9th St. N. W. Dept. T. Washington, D. C.

RARE GAS AND HIGH VACUUM LABORATORIES

Neon, Helium, Argon, etc.

We specialize in construction and development of all types of special thermionic valves, Neon glow lamps, Neon arc lamps, Mercury arc lamps, hot cathode and gas filled rectifiers, tubes utilizing the alkali and alkaline earth metals, and photo sensitive apparatus.

We supply testing apparatus for capacity and resistance measurements using neon lamps. Safest and quickest method.

Also, high vacuum pumps, manifolds, etc., made of lead, lime, pyrex or quartz glass. Special high frequency apparatus for electronic bombardment.

Photo electric cells \$20.00 each. Three electrode potassium sodium tubes \$10.00 each. Complete equipment for high vacuum work installed.

RADIO ELECTRICAL WORKS

Research Division, 23 Union Sq., New York, N. Y.

PATENTS

TRADE MARKS · DESIGNS
FOREIGN PATENTS

MUNN & Co.

PATENT ATTORNEYS

Associated since 1846 with the Scientific American

640 Woolworth Building, New York City

521 Scientific American Bldg., Washington, D. C.

1310 Tower Building, Chicago, Ill.

633 Hobart Building, San Francisco, Cal.

518 Van Nuys Building, Los Angeles, Cal.

Books and Information on Patents and Trade Marks by Request.

A demonstration of the Mirror-like Surface of Micarta.



Tune-in

on one of the Westinghouse Broadcasting Stations tonight

- KDKA**—East Pittsburgh, Pa.
- KYW** —Chicago, Ill.
- WBZ** —Boston, Mass.
- KFKX** —Hastings, Neb.

MICARTA RADIO PANEL

Micarta is used by leading radio manufacturers because of its low power loss, high dielectric strength and pleasing appearance. Micarta radio panels can be drilled and machined with ease.

SEE DIRECTIONS ON OTHER SIDE

Westinghouse Electric & Manufacturing Co.
1000 FRANKLIN ST.

Westinghouse

MICARTA

REG. U. S. PAT. OFF.

Adds Beauty to Efficiency

The careful planning and skillful workmanship which you give the concealed apparatus of your radio set deserve an attractive case. A Micarta Radio Panel will increase the praise of your friends by giving your set physical beauty as well as efficient reception.

Micarta has a satin-like lustre not affected by oil, water or time. Micarta will not warp, shrink or crack. Three attractive finishes—walnut, mahogany, and black, enable you to give your set a touch of individuality.

To drill Micarta is a pleasure. The drill easily cuts its way through, leaving a clean hole without the sign of a chip.

You will be proud of your set with its Micarta panel.

Insist upon a Micarta Radio Panel with its handsome finish. Identify the genuine at your dealer's by its distinctive orange and black envelope. This envelope protects you against substitutes.

WESTINGHOUSE ELECTRIC & MANUFACTURING COMPANY
EAST PITTSBURGH PENNSYLVANIA

Sales Offices in all Principal Cities of
the United States and Foreign Countries

Westinghouse

X85742

AT LAST!

The Perfect Inductance for 20, 40 or 80 Meters

Employing ISOLANTITE Dielectric

After Two Years of Research, We Have Evolved an Inductance Whose Losses Cannot Be Measured

We have always been satisfied that our inductances were the best available, but we have always striven to make improvements. As the pancake coil is considered the best, our attention for the past two years has been directed to testing various insulating materials. As a result, we have produced an Isolantite crosspiece to support the turns of inductance, which has no measurable losses and may be used on extremely high frequencies and powers.

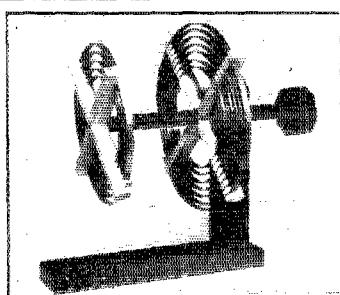

Quartz Crystals, \$6.50, Guaranteed to be cut along proper axis.

WAVE METER 20-200 METERS

\$18.75 Postage Enclosed in High Grade Extra Case Lamp with Indicator. Finest Material Used Throughout. Calibration Accurate within 1%. Full Line of Transmitting Parts. Write for bulletin

ISOLANTITE (a synthetic quartz) is being adopted by leading radio manufacturers of low loss parts. Its insulating qualities are superior to glass as it is non-hygroscopic and will not absorb moisture even when immersed in a liquid. It has none of the mechanical weaknesses of glass.

PRICE \$10.00

Postage Extra

ALL WOOD INSULATED INDUCTANCES

\$6.75 Postage Extra

COMPLETE PANEL MOUNTED TRANSMITTERS ON HAND FROM 5 WATTS UPWARD

J. GROSS AND COMPANY

For Personal Calls
Laboratory at 74 Dey St.,

907 Fox St., Bronx, N. Y. City
(Mailing Address)

Three "E" Straight Line RHEOSTAT

Perfect Control of Filament Temperature

Illustration 1/2 size. 6-15-30 Ohms

**WATTS,
4 FM**

tells you about this precision instrument straight from the shoulder.

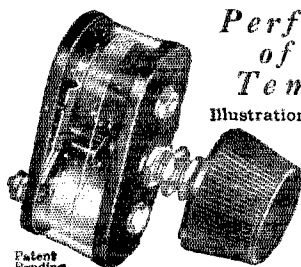

Patent Pending

Gives you a fine smooth, dependable variation of filament temperature. Runs smoothly, is absolutely NOISELESS, and once set, "stays put!" Sets a new standard of Rheostat performance, doing things that no other rheostat is expected to do. Used in the B. E. filament circuits of Neurodines and tuned R.F. sets, it controls volume smoothly, and without distortion, over the entire range. Equally efficient for short and long wave sets. By all means secure this precision instrument at once. Ask your dealer or order direct. Price \$2.50, Postpaid.

"Florida Radio Telegraph Co., Central Station W. R. B. Miami, Fla. Working on 15 to 40 meters. . . I combined the filament rheostat with the oscillation control, thereby eliminating one variable condenser and its attendant effect upon tuning. Your rheostat has no tuning effect whatever and is ideal for this purpose. I intend to equip the stations of this Company with it. E. G. Watts, Jr., 4FM"

Electrical Engineers Equipment Co.
Radio Division

708 W. Madison St., Dept. 7, Chicago, Ill.

Information on Request



RADIO OPERATORS WANTED

Radio Operators are needed on board ships sailing for Europe, The Orient, Africa, South America, etc. THE EASTERN RADIO INSTITUTE can train you quickly and thoroughly because:

MODERN and EFFICIENT METHODS
THOROUGH yet Simple INSTRUCTION
New and UP-TO-DATE APPARATUS
THIRTEEN Years a RADIO SCHOOL

The OLDEST, LARGEST, and MOST SUCCESSFUL school in New England. RECOMMENDED BY THE A. R. R. L.

Day or Evening Classes Start Every Monday.
Write for Illustrated Prospectus

EASTERN RADIO INSTITUTE

399 BOYLSTON STREET
BOSTON, MASS.

FAMOUS "BH" TRANSFORMERS

BH Vivaphonic (Registered)

A Straight-Line-Frequency Distortionless Transformer. Test curve made at McGill University shown in catalog. A full line of Transmitting Transformers. Ask your dealer for our literature or write us.

BENJAMIN HUGHES ELECTRIC CO.
298 Lagacheiere St., W. Montreal, Canada
Transformer Builders Since 1910

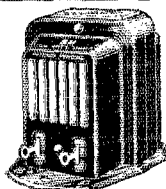

Laboratory Product



For Distortionless Amplification

Transmitting Grid Leaks for five watt tubes \$2.50. Dual Grid Leaks for one or two fifty watt tubes \$3.50. Standard Resistances \$1.50.

Crescent Radio Supply Co., 1 Liberty St., Jamaica, N. Y.

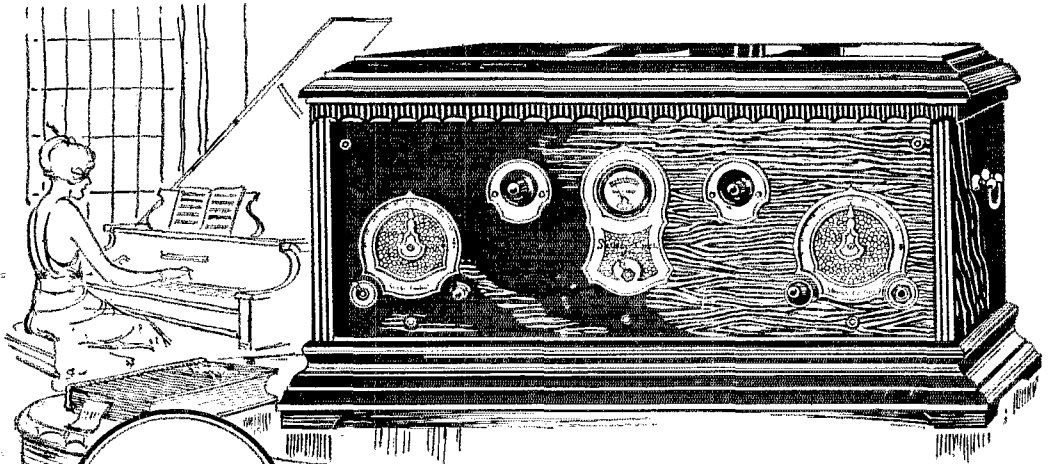

No. 601 Receiver, treasure chest type, 6-tube; totally shielded; dual control; operates horn or cone type Loud Speaker; Solid Mahogany.

Rate of Vibration

4096

2048

1024

512

256

128

64

32

The tone of Stromberg-Carlson Receivers is tested scientifically in the laboratory. Each instrument must be able to reproduce without distortion, every tonal vibration from the lowest C on the piano [32 vibrations per second] to the highest C [4096 vibrations per second.]

Stromberg-Carlson acoustic engineers guarantee the accuracy of Stromberg-Carlson tone. It is removed from all possibility of imagination, prejudice or relative hearing ability.

Fidelity of Tone

Musically cultured people prefer Stromberg-Carlson Receivers.

Those who appreciate fine violins, grand pianos, boxes at the opera and season tickets to concert courses know what well-played instruments sound like. They wish to appraise the playing of Hoffman, the singing of Homer, the technique of Seidel as accurately by radio as though seated before them.

They prefer a Stromberg-Carlson Receiver because of its faithful tone reproduction. This fidelity of tone is due in large measure to "*Rejectivity*," an exclusive Stromberg-Carlson feature, made possible by *totally shielding* each radio frequency circuit.

Any authorized dealer will gladly demonstrate the difference between tone which merely *approximates* broadcasting and tone which *duplicates* it—Stromberg-Carlson tone.

Stromberg-Carlson Telephone Mfg. Company
Rochester, N. Y.

Stromberg-Carlson

The "X" Laboratory Type Condenser

Competes With No Other Condenser in the Radio Field

To those whose exacting requirements nothing but the finest equipment will satisfy, this Condenser commends itself. It is built and inspected for Quality alone. Plates bevelled and buffed. Pyrex (glass) insulation adopted by American Tel. and Tel., U. S. Government, etc. A Straight Line Frequency Condenser, electrically perfect. Rugged metal frame housing stator and rotor units. Simple to install—tension and warping eliminated. Stator unit completely isolated electrically from housing by Pyrex (glass) insulator buttons. Rotor grounded to frame to prevent body capacity. Made with and without Vernier. Vernier is micro-gearred, ratio 200 to 1. No Back Lash.

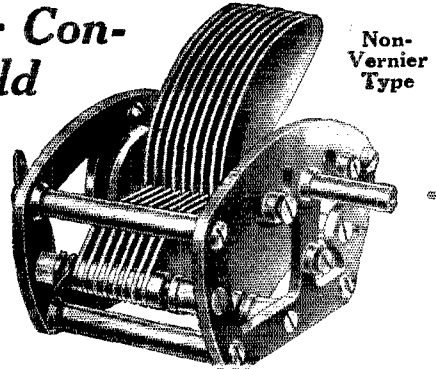

Non-Vernier Type

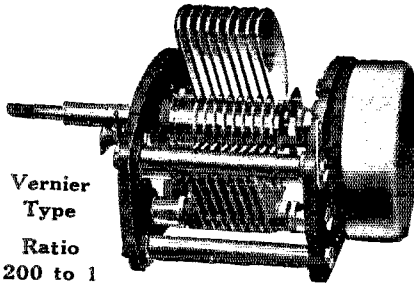

Vernier Type
Ratio
200 to 1

TEAR THIS OUT AND MAIL TODAY!

"X" Laboratories
29 West 45 St.
New York City

Enclosed is \$..... (M. O., Express Order, or stamps) for which please ship me

Capacity	Non-Vernier Stripped	Condenser with Dial	With Vernier, Dial and Knob
.00025	<input type="checkbox"/> \$7.00	<input type="checkbox"/> \$7.75	<input type="checkbox"/> \$9.00
.00035	<input type="checkbox"/> 7.00	<input type="checkbox"/> 7.75	<input type="checkbox"/> 9.00
.0005	<input type="checkbox"/> 7.50	<input type="checkbox"/> 8.25	<input type="checkbox"/> 9.50

Name.....

Address..... City.....

Fine Radio TOBE Apparatus

DEUTSCHMANN

TRANSMITTING CONDENSERS

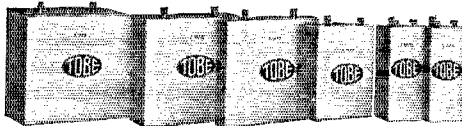

THE TOBE DEUTSCHMANN Transmitting Condensers are constructed with the same care and scrupulous attention to detail as the TOBE Filter Condensers. Each condenser is tested both for voltage break-down, and capacity, and labeled with date of test and initials of tester. Capacities are guaranteed within 5% of rating.

The higher voltage types are fitted with brass binding posts—the lower with heavy soldering lugs. Put up in beautiful matt-finish aluminum cases and so constructed as to hold their operating characteristics without variation. The ideal transmitting condenser for plate supply filters.

SIZES AND PRICES

Capacity	Mfd.	1000 Volts	2000 Volts
.1		\$1.10	\$2.25
.25		\$1.20	—
.5		\$1.40	\$3.25
1.0		\$1.75	\$4.50
2.0		\$2.65	\$7.50

TOBE DEUTSCHMANN CO.
CORNHILL BOSTON, MASS., U. S. A.

KNOW YOUR WAVE

The WIMCO Type A Wave Meter is accurate to 1/2 percent. Made to cover all amateur bands—get maximum results by being sure of your tuning. Used by the Army and Navy.

Send for Literature

The Wireless Mfg. Co.

Canton - - - - - Ohio

Transmitting Grid Leaks

5000 ohm Ward Leonard units

These are special Ward Leonard vitreous enamelled gridleaks having a rating of 44 watts continuous duty, big enough for 250 watters. The price is \$1.65 each plus postage on one pound. Brand new and guaranteed.

Every set needs a gridleak. Get yours today!

Utility Radio Company 58 North 6th St. Newark, N. J.

RADIO SCHOOL

Send for Catalogue

MASSACHUSETTS RADIO
and TELEGRAPH SCHOOL

NEW TERM JAN. 11

18 Boylston St.

Boston, Mass.

For COMMUNICATION or EXPERIMENTATION

These Batteries Give Your Radio Apparatus a Chance to Work Unhampered by Faulty Current Supply

Every "ham" knows that there is no such thing as radio without electricity. The best apparatus made won't give the results it is capable of giving if the "juice" isn't flowing right.

To give your apparatus a chance, use batteries that deliver current smoothly, quietly, and abundantly—as you need it. Use batteries that *last*. Batteries with *staying power* and with extraordinarily low internal resistance resulting in perfect fidelity of reproduction.

The father of radio broadcasting himself, Dr. Lee de Forest, uses Ray-O-Vac batteries for these same reasons.

He says, "Seeking the best that the market provided in a dry battery—one giving

the most uniform and level voltage, combined with low internal resistance and greatest life—I have come to use the French Battery Company's products because they most nearly approach my standard of requirements."

No matter what *you* expect of batteries, Ray-O-Vacs will meet your standards, too.

Try them *now*. Start from scratch. Equip your apparatus complete with Ray-O-Vacs for A, B, and C current. You will be delighted with the better and longer service they give you.

If the stores where you ordinarily buy do not have Ray-O-Vac radio batteries, write us for the name of the nearest dealer or jobber who can supply you.

FRENCH BATTERY COMPANY, MADISON, WISCONSIN

Ray-O-Vac "A" batteries re-ventilate during rest periods, lasting longer and giving excellent reception.

Ray-O-Vac 1/2 volt "C" batteries with 3 variable terminals give voltage adjustment of 1 1/2, 3 and 4 1/2 volts.

Ray-O-Vac "B" batteries in all standard sizes, both flat and upright.

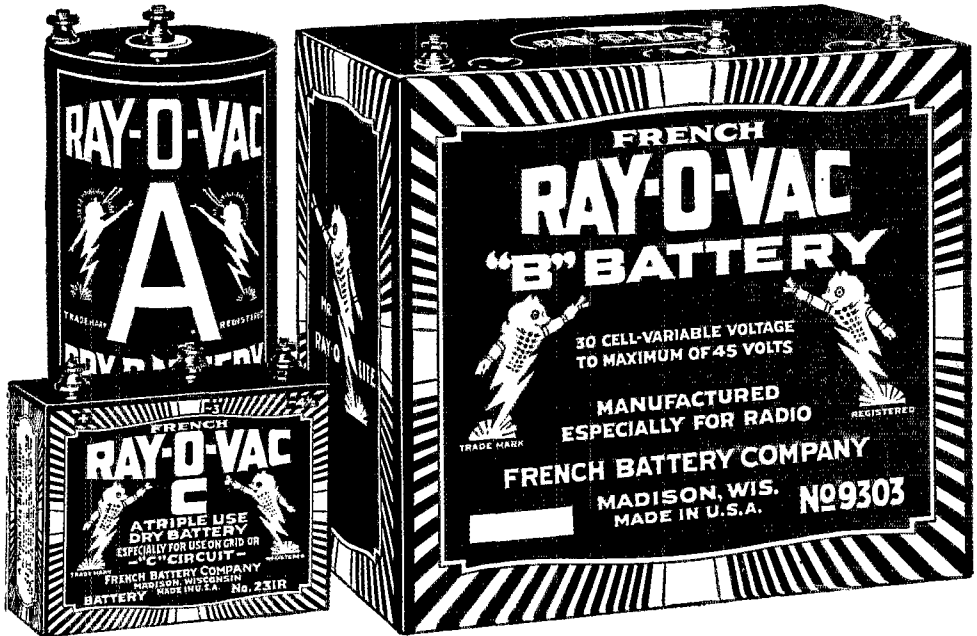

Also Makers of RAY-O-LITE FLASHLIGHTS and BATTERIES

SAY YOU SAW IT IN QST—IT IDENTIFIES YOU AND HELPS QST

To Our Readers Who Are Not A. R. R. L. Members

Wouldn't you like to become a member of the American Radio Relay League? We need you in this big organization of radio amateurs, the only amateur association that does things. From your reading of *QST* you have gained a knowledge of the nature of the League and what it does, and you have read its purposes as set forth on page 6 of every issue. We would like to have you become a full-fledged member and add your strength to ours in the things we are undertaking for Amateur Radio, and incidentally you will have the membership edition of *QST* delivered at your door each month. A convenient application form is printed below—clip it out and mail it today.

.....1926

American Radio Relay League,
Hartford, Conn.

Being genuinely interested in Amateur Radio, I hereby apply for membership in the American Radio Relay League, and enclose \$2 (\$2.50 in foreign countries) in payment of one year's dues. This entitles me to receive *QST* for the same period. Please begin my subscription with theissue. Mail my Certificate of Membership and send *QST* to the following name and address.

.....
.....
.....

Station call, if any

Grade Operator's license, if any

Radio Clubs of which a member

Do you know a friend who is also interested in Amateur Radio, whose name you might give us so we may write him about the League?

..... Thanks!



FOR ACCURATE CONDENSER VALUES USE X-L VARIO DENSERS

The Best Semi-Fixed Condenser Made. Endorsed by
All the Leading Radio Authorities.

MODEL N—Capacity range 1.8 to 20 micro-microfarads, for balance in Roberts two tube. Browning-Drake, McMurdo Silver's Knockout, Neutrodyne and tuned radio frequency circuits.

Price \$1.00

MODEL G—For the Cockaday circuit, filter and intermediate frequency tuning in super-heterodyne and positive grid bias in all sets. G-1 .00002 to .0001 MF. G-5 .0001 to .0005 MF. G-10 .0003 to .001 MF. PRICE EACH WITH GRID LEAK CLIPS \$1.50

X-L RADIO LABORATORIES, 2428 Lincoln Ave. N. Chicago

GRAVITY BATTERIES

Runs a 1/2 amp. tube for 240-3200 hours etc. \$40.00 net. Includes copper, zinc and jar. Voltage 1.00 per battery; 600-800 amp. hrs. Price, crated, for six, \$6.60. Extra zincs for renewals, six for \$2.65. Blue stone for making electrolyte, 25 lbs. for \$2.65. (3 lbs. per cell.) Shpg. wt. 75 lbs.

BALLOON AERIAL for best DX. Practically by fading as many air currents and strata are penetrated. Elbow and Hawaii on one tube with 3-circuit tuner (large, 5 in. single layer), counterpoise and Baldwin "G" phones. Price \$5.00 plus postage. All complete with two extra 30 in. balloons, extra aluminum antenna wire etc. Shpg. wt. 5 lbs. Gas prepared in tanks or make it.

CHIMNEY AERIAL. The best of the inside aerials. Is chimney high, large 6 in. case construction and super-sensitive. Protective by asbestos. Price \$2.00 plus postage (3 lbs.). Includes 75 ft. extra heavy. Write for literature.

INSULATED RIBBON WIRE. To be wound edge-wise for maximum inductance in 3-circuit tuners, radio coils, etc. Equivalent to No. 24 round wire. Price \$4.50 per lb.

EVERETT SCANLON, RADIO SPECIALTIES, LAKEWOOD, RHODE ISLAND.

Quick Certain Tuning!

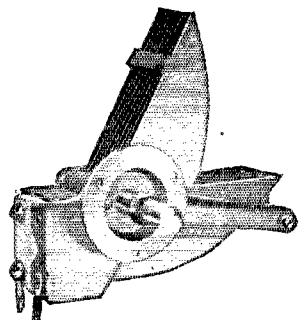

PACENT TRUE S. L. F. CONDENSER
 Cat. No. 251B .00035 Mfd. Max. Price \$3.50
 Cat. No. 251C .0005 Mfd. Max. Price \$4.50

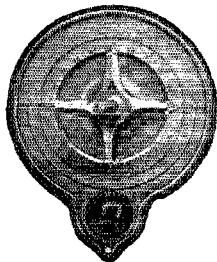

PACENT MICROVERN
 Cat. No. 150S Silver Price \$2.00
 Cat. No. 150G Gold Finish Price \$2.00

PACENT ELECTRIC COMPANY, Inc
 91 Seventh Avenue, New York City

Washington
 Minneapolis
 Boston
 San Francisco
 Chicago
 Birmingham

Pacent
RADIO ESSENTIALS

Philadelphia
 St. Louis
 Buffalo
 Jacksonville
 Detroit
 Pittsburg

Canadian Licensed Manufacturers: White Radio, Limited, Hamilton, Ont.
 Manufacturing Licensees for Great Britain and Ireland:
 Igranic Electric Co., Ltd., London and Bedford, England

THESE two precision instruments—products of the Pacent Laboratories—take the guesswork out of tuning. Their installation on any set guarantees an ease and certainty in tuning that will amaze even the veteran radio fan.

The Pacent TRUE Straight Line Frequency Condenser charts a REAL straight line frequency and gives you correct, uncrowded, uniform spacing all around the dial. Mechanically and electrically right: One or three hole mounting. Can be mounted tandem for mono control. The results you will obtain from its use will prove that it is a REAL Straight Line Frequency Condenser

The Pacent Microvern is a Super tuning device. No gears. No backlash. Exclusive Pacent Radiofile for simple logging and reading of stations by name, wavelength and frequency. Easy to mount. You will find the MICROVERN a real vernier for real sharp tuning.

Your Dealer will gladly tell you about these and other Pacent Radio Essentials—or we will send you direct, our latest illustrated catalog.

FOR THE TRANSMITTING

AMATEUR

COMPLETE TRANSMITTERS OF EVERY DESCRIPTION

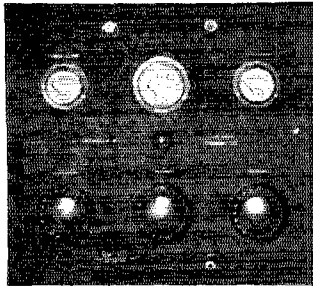

MOUNTED ON BAKELITE OR TREATED MAPLE-WOOD PANELS AND FRAMES

Receivers 10 to 110 meters short-wave Receiving Apparatus

SPECIALS

AMRAD "S" Tubes 4000-1 \$8.00
 " " 5000-1 6.00
 Change-over switch 6.00
RCA UX-210 7 $\frac{1}{2}$ Watt . . . \$8.00
 UV-203—UV-203-A } Special
 UV-204—UV-204-A }

PYREX

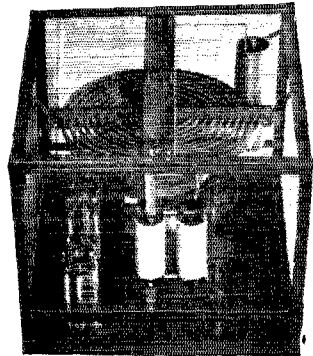

ALL SIZES STRAIN INSULATOR

ALL TYPES LEAD IN BOWLS

Lowest loss coupled transmitting inductances, insulated throughout with pyrex glass, any wave band, with clips. Price \$10.00

Complete stock of Acme and Thordarson transformers and chokes, Jewel and Weston Meters, Bradley Radiostats, Filter Condensers, National Condensers. Low loss coupled transmitting inductances . . . \$6.75. Special mountings for DeForest type-H tubes.

Send for Our Monthly Bulletin

Estimates Gladly Given on Special Jobs

Amateur Radio Spec. Co.

77 Cortlandt St. New York City

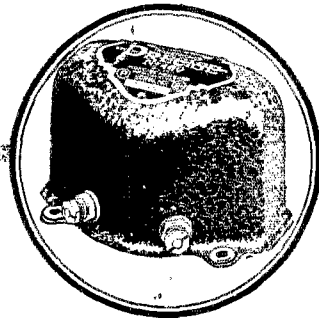

The Big Precise "480" —A Master Transformer

Designed for radio reception in a concert hall if necessary. Brings forth the deep rich tones and the high clear tones with magnificent volume. The ratio of voltage amplification to frequency is practically a straight line, assuring uniform amplification over the entire range of useful audio frequencies. Made in two ratios, 2 $\frac{1}{2}$ to 1 and 5 to 1.

Price, either ratio, \$7.50.

PRECISE MFG. CORP.
ROCHESTER N. Y.

As a direct result of a suggestion by A.R.R.L. Headquarters, Cardwell Transmitting Condensers will be sold hereafter direct to amateurs, at materially reduced prices.

Type 147-B, 440 mmfds. maximum capacity, 3000 volts breakdown, formerly priced at \$15.00 will sell at \$10.00 and other prices will be changed accordingly.

When ordering, give your call letters.

Allen D. Cardwell Mfg. Co.,
81 Prospect St., Brooklyn, N. Y.

MAKE YOUR RADIO SKILL PAY!

Radio Operators—sea or land—are well paid for pleasant work. Learn commercial radio at home in spare time—courses for Radio operators, mechanics, dealers. Also school classes.

Write NOW for free YMCA Radio Institute booklet:
"OPPORTUNITIES IN RADIO" 159 East 86th St. New York.

RADIO STUDY AT HOME

Radio, the wonder of all ages, has grown with gigantic strides. Radio experts are needed to keep pace with the growth. Thousands of good-paying positions are open to trained men. Be a radio expert—earn big money—travel—get into the limelight—obtain command power and fortune ahead for men with vision now just as there was when Henry Ford got started on his auto. The opportunity is here.

YOU EARN WHILE YOU LEARN

Our home-study course in practical radio can be mastered by you in 2 months. Become a radio engineer. Write for free booklet, "Millions Untouched" and "RADIO" if you will now. Send letter or postal to: **RADIO UNIT J. Mendel—learn how to make \$100 wk. AMERICAN RADIO ENGINEERS.**
Dept. 15, Hearst Bldg., Chicago, U. S. A.

HAM-ADS

IMPORTANT NOTICE! NEW RATES ADVANCED CLOSING DATE

Effective with May QST, the HAM-AD Advertising Rates are TEN CENTS A WORD. Name and address to be counted, each initial counting as one word. These rates are shown on QST Rate Card No. 6, in force with the May issue.

The closing date for HAM-ADS is now THE TWENTY-FIFTH OF THE SECOND MONTH PRECEDING DATE OF ISSUE. For example, all HAM-ADS for the June issue must be in this office not later than April 25.

Hereafter no HAM-AD will be accorded any particular or special position.

Rates for the QRA Section remain the same; 50c straight. See heading of that section for details.

MOTORS—New G. E. $\frac{1}{4}$ HP \$12.50, $\frac{1}{2}$ HP \$28.50, 1 HP \$45. GENERATORS—Radio Transmission 500V \$28.50. Battery Chargers—Farm Lighting generators all sizes. Lathes, Drill Presses, Air Pumps other Garage and Shop equipment. Wholesale Prices. New Catalog. MOTOR SPECIALTIES CO., Crafton, Penna.

TELEGRAPHY—Morse and Wireless—taught at home in half usual time and at trifling cost. Omnigraph Automatic Transmitter will send on Sounder or Buzzer unlimited messages, any speed, just as expert operator would. Adopted by U. S. Govt. and used by leading Universities, Colleges, Technical and Telegraph Schools throughout U. S. Catalog free. Omnigraph Mfg. Co., 13M Hudson St., New York.

"The Hawley." An alkali non-acid rechargeable "B" storage Battery of 22½ volts. Not an unassembled battery but ready to use—no extra parts to buy. Uses the largest sized tested Alkaline elements (Edison). Heavy closed top glass cells. Chemical electrolyte included and shipped separate. Any detector or amplifying voltage easily had. Special offer. 4-22½ volts (90 volts) \$10.00; 112½ volts \$12.50; 135 volts \$14.75; 157½ volts \$16.80. For those wishing to put their own together buy the knock-down kits. Put up in all voltages at still greater savings in price. The only battery of its kind sold on a 30 days trial with complete guaranteed satisfaction or your money returned in full without any ifs, ands, or buts. Further guaranteed 2 years. Order direct—send no money. Simply pay expressman its cost plus the small carrying charges. Patent pending. Same day shipments. Write for my guarantee testimonials and literature. It's free and it's interesting. Complete sample cell 35c prepaid. B. Q. Smith, 31 Washington Ave., Danbury, Conn.

REAL BARGAINS—UP—1016 \$38.00 R. C. A. 750 watt Power Transformers, \$12.50—UP—1656 Filament Transformers 75 watts, runs 4 five watters, \$4.00—up-1658 Filament Transformers, 150 watts, runs 2 fifties \$5.00—UL-1008 Oscillation Transformers, \$5.00—UP-414 Micro-SAY YOU SAW IT IN QST—IT IDENTIFIES YOU AND HELPS QST

phone Transformers, \$3.75—UV 712 Amplifying Transformer, Audio Frequency, \$2.50—UC-1831 Variable 4000v Transmitting Condensers, \$1.50—UC-1803 Antenna Coupling Condensers, \$1.50—EF Battery Chargers, 110v 60 cyc. 6 amp. rate, \$9.00—G. E. 110v AC Motor 1/32 HP, 7000 RPM, \$3.50—Amrad No. 2796 Lightning Switches, \$1.50—Amrad No. 2834 Send-Receive Switches, \$5.00—Amrad No. 3650 Variometers, \$1.50—Circuit Breakers, adjustable around 10 amps, \$2.50—Amrad type F \$25.00 Long Wave Tuners, 2000-20,000 meters, \$8.00—Send for discount sheet and keep in touch with bargains. All items sent post-paid up to 4 Lbs. STATE RADIO CO., 286 Columbia Road, Dorchester, Mass.

MAKE \$120 WEEKLY IN SPARE TIME. SELL what the public wants—long distance radio receiving sets. Two sales weekly pays \$120 profit. No big investment no canvassing. Sharpe of Colorado made \$955 in one month. Representatives wanted at once. This plan is sweeping the country—write today before your county is gone. OZARKA, 853 Washington B'vd., Chicago.

SELL JEWELL high voltage Meter. General Radio Laboratory Condenser, Wavemeter, Audibility Meter. #AAL, 4602A Delmar, St. Louis, Telephone, Main 0326.

EVERYTHING in RECEIVING apparatus. Over 2 pounds data, catalog, etc., prepaid anywhere—25c. Discount to "hams." Kladag Radio Laboratories, Kent, Ohio—if you can't find it anywhere else, ask us as we have the largest stock of highgrade parts between N. Y. and Chicago.

COMPLETE PRINTING OUTFITS, presses, type, ink, paper, supplies. Write for catalog. Press Co., C-95, Meriden, Conn.

200-20000 METER RECEIVER including Radiotron \$25.00. Two step amplifier \$15.00. Smith, 4416 Market St., Philadelphia, Penn.

DO you envy the ham with the bird like note? Most likely he is using a GOOD generator. The best were made for the government. Hundreds sold already, number left, BUT THEY WILL NOT LAST FOREVER. General Electric 24/1500 volt .233 ampere (350 watt) 6000 RPM 112 segments unused @ \$45.00. Slightly used guaranteed perfect \$25.00. IDEAL FOR BATTERY PLANTS \$3.00 additional with shaft for belt drive. Results equally as satisfactory. Crocker-Wheeler 24/1500 volts 450 watts 6500 RPM 100 segments, \$45.00 GE 12/350 volt 143 amperes with filter condenser \$18.00 Holtzer-Cabot 12/600 volts .07 amperes \$18.00. ALL ball bearing machines. Ten volt twenty ampere Army batteries \$5.00. Navy keys with blinker light \$2.00—500 cycle motor generators. BEST prices on Cardwell condensers: Cardwell 2 step amplifiers \$15.00. Henry Kienzle, 501 East 84th Street, New York.

THE SHORT WAVE RECEIVER THAT IS A CHALLENGE TO OTHERS. THE DX FOR THE BUG AND EFFICIENCY FOR THE TRAFFIC MAN. THE RANGE IS FROM 5-200 METERS. THE HIGHEST QUALITY PARTS ARE EMPLOYED. N. Z., THE AUSSIES AND ARGENTINE ARE COPIED GOOD WITH THE ENSALL RADIO LAB SHORT WAVE RECEIVER. DETAILS ON REQUEST. IT HAS COPIED ITALY ON A LOOP, ALTHOUGH NOT DESIGNED FOR THAT WORK. WE ALSO BUILD TO ORDER TRANSMITTERS TO COVER ANY OF THE AMATEUR WAVELENGTH BANDS. INDUCTANCES FOR ANY TRANSMITTER OR RECEIVER. ALSO WAVEMETERS, SPECIAL INDUCTANCES, ETC. WE SUPPLY ONLY THE HIGHEST GRADE PARTS FOR AMATEUR RADIO. NO CUT RATE HERE. PYREX, ESCO, THOR-DARSON, ACME, GENERAL RADIO, JEWEL, WESTON, FARADON, AND OTHER MANUFACTURERS EQUIPMENT. WE BUILD POWER CONTROL PANELS TO PUT THE FINISHED LOOK TO YOUR STATION. DOPE ON REQUEST. WE CATER TO THE BROADCAST GANG ON THE SUPER-HETERODYNE AND TO THE GANG IN THIS LINE AT A DISCOUNT WHEN YOU FURNISH THE DESIRED INFORMATION. IF THE SUPER-HETERODYNE WON'T WORK, FOR YOU OR YOUR CUSTOMERS, SEND IT TO US. FOR THE BEST IN AMATEUR RADIO DROP US A LINE. QUOTATIONS GLADLY FURNISHED ON ANY WORK. JUST GET QSO. THOS. ENSALL (ENSALL RADIO LAB.,) 1208 GRANDVIEW AVENUE, WARREN, OHIO. ("Designers Of High Grade Amateur & Broadcast Equipment").

Transmitting Sets—Modulators, Oscillators, Speech Amplifiers. All Waves from 20-600M. Fully Mtd. with Meters or constructed to Order. Rebuilt or Rewired at interesting prices. S. Strobel, 3923 N. 6th St., Phila. Penna. (3BOV).

PURE ALUMINUM and lead rectifier elements, holes drilled with brass screws and nuts per pair 1/16", 1"x6" 13c. 1 x 6, 15c. 1 1/4 x 6, 17c. 1 1/2 x 6, 19c. single elements half price. Sheet aluminum 1/16", \$1.00, 1/8", \$1.90. Lead \$1.00 square foot all prepaid. GEO. SCHULZ, Calumet, Michigan.

CURTIS-GRIFFITH OFFERS: JEWELL VOLTMETERS 0-15 AC \$6.95; 0-500 MILLIAMMETERS \$6.95. THOR-ARSON POWER TRANSFORMERS 550 Each Side \$9.95. SPECIAL POWER-FILAMENT 250 WATT 550 each side \$10.50. ALUMINUM square foot 85c; LEAD square foot 85c. No. 4000-A "S" TUBES \$7.50. "HAM-LIST" 3c. (No CODS) CURTIS-GRIFFITH, 1109 Eighth Avenue, Fort Worth, Texas.

BALLANTINES WANTED. State your price and condition of book. Countless new-born hams need the book, now out of print. You can help your future fellow-ham by selling yours if you have no immediate need for it. New and completely revised edition will be out by spring or earlier, anyhow. Advise Information Service, A.R.R.L., and we will refer purchasers to you.

SETS and parts cheap—closing out everything. Three tube Paragon—two tube Harkness—five tube sets—one tube sets cheap. The Radio Exchange, 710 No. Kings-highway, St. Louis, Missouri.

RECEPTION KEEN AND SNAPPY AS THE CRUNCHING SNOW. CLEAR AS A WINTER'S NIGHT*. IF YOUR PLATE POWER SUPPLY IS AN EDISON B (THE 8ML KIND), NO JOINTS, PURE NICKEL CONNECTORS ELECTRICALLY WELDED FOR ABSOLUTE QUIET. GIVE YOUR SET A CHANCE WITH ONE OF THESE. 54 VOLT \$8.25, 100 VOLT \$15.00. OTHER SIZES. OAK CABINET. LARGEST ELEMENTS. REAL EDISON SOLUTION. A BIG REAR OF A B—2000 MILIAMP HOUR FOR THE MULTITUBE SET, 105 VOLTS \$24.00. ASSEMBLED CELLS 24c. SAMPLE 30c. QUANTITY DISCOUNTS. PEPPY EDISON A ELEMENTS 5c. WELDED PAIRS 7 1/2c. GIANT SUPERCELL 4000 MILIAMP HOUR 40c. SAMPLE 50c. ANNEALED TEST TUBES 3/8", 1", 1 1/2", 2", 3", 4". SHOCKPROOF JARS 1x6"—4c, 1 1/4"x6 1/2"—5c. PUREST SOFT .032 NICKEL 1c FT., .034 (HEAVY) 1 1/4c FT. RUBBER SEPARATORS 14c. REAL EDISON ELECTROLYTE (THAT'S NO LYE) LITHIUM COMPOUND \$1.25 MAKES 5 LBS. WILLARD COLLOID—A REAL H CHARGER \$2.00, JUMBO \$3.00 (FULLWAVE USE 2). BRING YOUR AERIAL UP TO QST SPECIFICATIONS WITH NO. 12 SOLID COPPER ENAMEL AERIAL WIRE. 75c 100 FT. PYREX INSULATORS. LEAD-IN BOWL TYPE PYREX \$1.50. PRESCRIPTIONS FREE FOR AILING B's. FRANK M. J. MURPHY, 4837 ROCKWOOD ROAD, CLEVELAND, OHIO.

FREE—One year subscription to a "HAM" MAGAZINE or a RADIO CALL BOOK with each order. AMRAD 4000-1 S tubes, receptacles FREE; \$10.00 Prepaid. Five tube tuned radio frequency sets; \$32.50. AGENTS WANTED. Locust Radio Company 117-19 168th Street, Jamaica, N. Y.

WESTERN Electric loudspeakers complete \$60, unused UV203 \$15, real prices on transmitting parts. Darrell Gretorex, 6315 17 Ave., NE, Seattle.

HAMS ! ! The latest in RADIO PRINTING! Embossed and printed radio cards, radio calling cards, radiograms, stationery. Very low prices. Samples FREE. QUALITY WORK. THE ARTHUR PRESS, 1453 Arthur Avenue, Lakewood, Ohio.

MOUNTED POWER TRANSFORMERS. 200 watt-700 v. and 1100 v with midtaps \$12.50, 300 watt 1500v and 2000v with midtaps \$16.50, 1000 watt 2000v and 3000v with midtaps \$25.50. State voltage of filament winding necessary. Rated voltage and output guaranteed. Postpaid. Write for prices on special or other standard transformers. M. C. Zumpfe, 1332 Mishawaka Avenue, South Bend, Indiana.

COMPLETE fifty watt transmitter sixty-five dollars. Includes new 208A, three Jewell meters, Cardwell series 90

condensers. All parts in good condition. DX New Zealand. All correspondence answered. 6SK, Ft. Worth.

AT last a high tension double spaced variable condenser at a reasonable price, hard rubber insulation, double or treble spacing as desired, calibrated spacers 1/10 inch thick, brass parts nickel plated, plates aluminum polished, shipped knocked down, can be assembled in 1 hour. Extra parts can also be had separately increasing capacity. 23 plate size all parts included with complete printed directions and photos for assembling \$3.50 postpaid if cash with order, postage extra on C. O. D. Satisfaction guaranteed or money refunded. Geo. Schultz, Calumet, Michigan.

EXPERIENCED AMATEUR AND COMMERCIAL OPERATOR HIGH SCHOOL GRADUATE AND ONE YEAR IN LEADING ENGINEERING COLLEGE DESIRES POSITION IN BROADCAST STATION, RADIO LABORATORY OR MANUFACTURING CONCERN. OLIVER LEWIS, PROFFIT, VIRGINIA.

HURRY ! ! Four UV203A's, absolutely new, \$21 each. 250 watter \$35. Everything excellent condition. Also all transformers, etc. Sacrificing everything. Rush! B. T. Vail, 1761 State Street, Schenectady, N. Y.

DODGE RADIO SHORTKUT with APPENDIX and HELPFUL HINTS for BETTER KEY WORK Kills Hesitation in Reading Transmitted Code Cultivates and Develops Legible Transmission SPECIMEN REPORTS FROM STUDENTS 6QM Lewiston, Calif. Speed was five. Shortkut secured my License. 7ADJ Albany, Oreg. Had tried everything. No success. Shortkut made it easy. 8BRB Apollo, Pa. Ten minutes killed all Hesitation. Speed was 6. Now 20 per. 2ML Stevens Point, Wis. Was anchored at 10. Now copy 20 without trouble. e3ADY Windsor, Ont. Speed was 6. Now 20 per Result of attention 6 evenings. RELIABLE DATA AS TO THIS METHOD may be found in HONOR ROLL which consists of REPORTS FROM 200 STUDENT HAMS Indiscriminate mailing of H. K. discontinued. If interested send 25 cents for copy in which find coupon that amount good when purchase. We deliver by Registered Mail—None COD Appreciate and expect Money Order remittance Shortkut; Appendix: Helpful Hints \$3.50 Helpful Hints and Appendix \$1.50 FOREIGN—Except Canada—ADD FIFTY CENTS. DODGE RADIO SHORTKUT, MAMARONECK, N. Y.

FOR SALE: My honeycomb coil set 19 honeycomb coils 10 special coils, three stage amplification. Price \$65.00. P. T. Perdue, Salem, Virginia.

OMNIGRAPHS, ELIMINATORS, VIBROFLEXES, BOUGHT, SOLD, RYAN RADIO CO., HANNIBAL, MO.

"WAVEMETER (Telefunken) 80-2500 meters electrically and mechanically perfect like new \$75. Special Foote Pierson tape register designed for high speed radio telegraph reception resistance 2000 ohms lightly used \$65. Room 18 246 West 59th Street New York City G. Meyer."

AMRAD S tube for sale-special-\$4.95. A large stock of generators on hand. Central Radio Company, 193 Center Street, New York City.

EDISON B BATTERY SUPPLIES. LARGEST SIZE TYPE A ELEMENTS 1c A PAIR, DRILLED 5c A PAIR, WIRED IN PAIRS 8c. PURE NICKEL WIRE 1c A FOOT. PERFORATED RUBBER SEPARATORS FOR BATTERIES 1/3c EACH OR CUT YOUR OWN SEPARATORS FROM SHEETS 5 3/16 x 5 3/8", 3c A SHEET. CHEMICALS FOR 5 LBS. BATTERY SOLUTION, ENOUGH FOR 100 VOLTS, 75c. EDISON 800 AMPERE HOUR A BATTERIES IN PERFECT CONDITION 58c. ALL ARTICLES POSTPAID. SEND REMITTANCE WITH ORDER. BERNARD STOTT, 60 PALLISTER AVENUE, DETROIT, MICH.

FOR SALE CHEAP; 50 watt transmitting set complete. In use for past year at 1-DZ. 3500 mile record. All letters answered. L. Kidd, 240 Broadway, Lawrence, Mass.

IT IN QST—IT IDENTIFIES YOU AND HELPS QST

STAMPED QSLs PRINTED AS YOU SPECIFY—Per hundred—Black \$1.90—Duocolor \$2.40—Each additional hundred 20c less—9DOA.

NEW LICENSE EXAMINATION QUESTIONS INEVITABLE SOON. PREPARE TO SKETCH A MODERN VACUUM TUBE MARINE TRANSMITTER. COMPLETE BLUEPRINTS OF LATEST SHIPBOARD CW TRANSMITTER, MOTOR-GENERATOR, AUXILIARY BATTERY AND RECEIVER, \$1.00. COMMERCIAL RADIO TRAFFIC MANUAL ONLY BOOK PUBLISHED ON HANDLING COMMERCIAL TRAFFIC, \$1.00, BOTH FOR \$1.50. Howard S. Pyle, 1922 Transportation Building, Chicago.

550v, 200 WATT power transformer \$6.00. Robertson chopper and Westinghouse motor complete, excellent condition, cost \$35, sell \$25. 8KJ.

SELL: Two fifty watt radiotrons, eighteen dollars each. J. K. Moore, Gadsden, Alabama.

SACRIFICE: SALE OR TRADE: Over five hundred dollars worth of radio apparatus, sets, trap drum outfit, popular radio magazines. Milburne Sharpe, Middlesboro, Kentucky.

RCA LEAKS 25c DOLLAR ASSORTMENTS now prepaid. The biggest lot of lugs, screws and gadgets you ever saw. Headquarters for GENERAL RADIO parts. Write for bargain list. Every piece of radio material carefully tested before shipping. The only mail order house giving this service FREE. Tubes matched at no extra charge. BARROWS RADIO LAB., 4-6 Columbia Rd., Portland, Me.

FOR SALE: Two U. V. 203's with sockets. One tube never used. 0-5 Jewell thermo-couple ammeter. 0-15 Jewell A. C. voltmeter. R. C. transmitting inductance and large 5000 ohm grid leak. Forty-five dollars. K. Downs, 815 North Lombard Avenue, Oak Park, Illinois.

WESTERN ELECTRIC portable telephones in leather cases \$2.50. Charles Slentz 22 S. 17th St., Harrisburg, Pa.

FOR sale 1500v 250w Ra-di-co MG 110v 60c A-1 shape. Stanley Surber, Francesville, Ind.

HELIX clips, best imported, no danger, can adjust with 1500 volts on hard rubber insulation 35c, 3 for \$1.00 postpaid. Geo. Schulz, Calumet, Michigan.

RADIO AMATEURS Improve your set with a Faradon Mica Condenser, Model UC 1015, made expressly for Radio Corporation. Only \$1.00. Originally listed \$5.25. Capacity range .0002 to .001 mfd. All brand new and packed in original containers. Instruction sheet enclosed. Send your order in now! Utility Radio Co., 56 No. 6th St., Newark, N. J.

"EVERYTHING FOR THE HAM. THAT'S US. No. 12 "DYNEX" SOLID COPPER ENAMELED WIRE, 1c FT. No. 10 (FOR HEAVY DUTY) 1-1/4c FT. PYREX GLASS TRANSMITTING INSULATORS, 1.50. RECEIVING SIZE, 45c. 1/16" LEAD AND ALUMINUM, 90c FT. "DYNEX" KEM RECTIFIER ELEMENTS, 1" x 4", 6c. 1" x 6", 7c. 1-1/4" x 6", 8c. "S" TUBES, \$10.00. No. 16 COTENEMEL, 75c LB. WE CARRY A COMPLETE LINE OF RCA, ACME, JEWELL, CARDWELL, GENERAL RADIO, ETC. TRANSMITTING PARTS. DON'T FORGET TO SEND FOR OUR NEW CATALOGUE IF YOU HAVE NOT ALREADY RECEIVED A COPY. "DYNEX FOR DX." NICHOLSON ELECTRIC CO. (FORMERLY E. J. NICHOLSON, 8BIN) 1407 FIRST NORTH ST., SYRACUSE, N. Y.

"TELEFUNKEN 200 WATT POWER TUBES \$70.—Filament 14 volts, 4 amperes; plate 3000 volts. Arthur H. Beyer, 106 Morningside Drive, New York City."

BARGAINS—SELL OR TRADE—EVERYTHING—JEWELL R. C. A. GENERAL RADIO TRANSMITTING APPARATUS. WANT GRAFLEX 45 COLT AUTOMATIC OR BINOCULARS. DROP CARD FOR LIST. W. L. HOLST—9CRF.

UM533 HOT wire ammeters \$1. Roller-Smith radio frequency ammeters 0 to 5, \$3. UC1015 mica condensers \$1. 1831, \$1.50. 1808, 50c. 750 volt 1/2 mfd 70c. Western Electric 2mfd \$1.25. Federal bussers \$1. RCA superheterodyne 1716 transformers \$3. Low voltage Amrad S tubes \$3. Neon tubes \$3. Used generators, 1500 volt 3600 speed SAY YOU SAW IT IN QST—IT IDENTIFIES YOU AND HELPS QST

\$20. 500 volt 500 watt \$15. 750 volt, 250 watt. 3600 speed \$20. Microphones \$1. RCA microphone transformers \$3. Postage extra. Have some RCA 1016, 750 watt transformers, oscillation and filament transformers and 202s which are 1/2 the list price, postage extra. No. 14 enameled 50c, 100 ft. R. Wood, 33 Way Ave., Corona, N. Y.

EDISON ELEMENT STORAGE "B" BATTERIES FOR SALE. ASSEMBLED AND WIRED. COMPLETE IN EVERY DETAIL. WELDED ELEMENTS, OAK RACK, ENGRAVED PANEL, POTASH AND OIL INCLUDED. 100 VOLT TYPE "A", \$11.00. 140 VOLT TYPE "A", \$15.00. 160 VOLT TYPE "A", \$17.00. 100 VOLT TYPE 5-G HEAVY DUTY, \$19.50. 140 VOLT TYPE 5-G, \$26.00. YOUR MONEY BACK IF NOT SATISFIED. WELDED TYPE "A" ELEMENTS, 5c PER PAIR. 3/8x6" CONTAINERS 3c. SEPARATORS, 1/3c. NO. 20 PURE NICKEL WIRE, 1c PER FT. NO. 15, 1/4c. CAUSTIC POTASH FOR MAKING 5 LBS. SOLUTION, 85c. J. ZIED, 904 N. 5th ST., PHILA., PA.

\$3.00 New Roller Smith Hot Wire, type CAR Radio frequency Ammeters, from 0-2 to 0-6, amperes, worth \$10.00 we have \$10,000, worth United States Government Aircraft Department Radio Transmitting Receiving Sets and Parts. Get our new and latest reduced price list. Send stamp for list. Mail orders answered all over the world. WELL'S CURIOSITY SHOP, 20 South 2nd St, Philadelphia, Pa.

YL'S-HAMS OMS. 30-220M. Wavemeters. Accurate to 1% \$7.50. 3BOV.

THORDARSON 650-VOLT POWER FILAMENT TRANSFORMERS for 5-WATERS \$6.90. (No C. O. D.'s.) CURTIS-GRIFFITH, FORT WORTH.

SELLING 50 watt transmitter. 203A tube. Thordarson transformers, etc. 8CP.

WE7A AMPLIFIER \$15.00. Speaker \$8.00. Parts for 7A \$8.00. 216A tubes \$4.00. R. Breunig, 2252 Roscoe Street, Chicago, Ill.

RECTIGON 2 ampere chargers \$13.85—5 Ampere; \$19.85. With bulbs, Scaled Cartons. Lucust Radio Company 117-19 168th Street, Jamaica, N. Y.

FOR SALE—New 204A tube \$90. WCAJ

IMFD. WESTERN ELECTRIC CONDENSER for B eliminator, 500 volt new \$1.00. 3 for \$2.50 prepaid. Geo. Schulz, Calumet, Michigan.

National .00015 MFD Transmuting condensers complete with velvet vernier dials \$7.00; ISOLANTITE SOCKETS FOR 5 WATERS 201-A's AND X TYPE TUBES STILL GOING BIG AT 60c; Rojee 5 watters are FB \$3.00; and the ROICE RECEIVING TYPES ARE THE BERRIES TOO, WE SELL ALL TYPES AT \$1.60; Findlay 6" standoff insulators prevent absorption losses 45c; postage on equipment extra; SEND FOR OUR HAM CATALOG IT'S FREE AND CONTAINS SOME GOOD CONSTRUCTIONAL DOPE. THE HAM SHOP 501, RUSTON, LA.

Five tube receivers used by air service, two stages audio and two stages radio frequency, mounted in neat wooden box on rubber cords. Sold with cords and connections but without batteries, phones or tubes. While they last, \$4.00. Generator filters, W E make, contain heavy choke coil, two 500 volt condensers, resistances and extension cord. In original cases, \$2.00. 1000 volt W E condensers, one microfarad, 40 cents; 500 volt W E condensers, one microfarad, 35 cents; two microfarad telephone condensers, 30 cents; heavy choke coils 3A \$1.50 each. J. A. Howenstine 2100 South High St., Columbus, Ohio.

SELLING OUT. WRITE FOR LIST NOW. WILLIAM LAFON, TAYLOR, TEXAS.

BETTER Edison elements, welded connections, 7c pair. Sample cell 10c. Paul Mills, Woodburn, Oregon.

HAMS: Get our Samples and Prices on Printed Call Cards made to order as YOU want them. 9APY, HINDS & EDGARTON, 19 S. Wells St., Chicago, Ill.

Motor Generator Bargains. Western Electric 110-220 V. Alternating Generator 1500 Volts 600 Watts \$135.00. Robbins & Myers 220 V. 60 cycle three phase; Generator 750 V. 400 Watts \$60.00. Esco 110 V.; Generator 350 V. 100 Watts \$30.00. Robbins & Myers 110 V. 60 cycle single phase; Generator 750 V. 400 W. \$70.00. Esco 220 V. 60 cycle 3 phase 1750; Generator 400 V. 100 W. \$25.00. 110 V. A.C. 260 V. D. C. \$25.00. 220 V. Direct Current Generator 1500 V. 500 W. \$75.00. All above machines are ring oiled. Also many others including several 3000 and 4000 V. machines. $\frac{1}{2}$ H. P. 220 V. 60 cycle 3450 speed motors \$8.50, 110 V. \$9.50. Write us for prices on anything in motors, generators and motor generators, stating kind of current voltage etc., QUEEN CITY ELECTRIC CO. 1734 GRAND AV., CHICAGO, ILL.

MONTH BY MONTH OUR BUSINESS IS INCREASING. EVERY STATE AND PROVINCE ON THIS CONTINENT CONTRIBUTE ITS SHARE, AS WELL AS "THE FOUR CORNERS OF THE EARTH." THE REASON IS THE SERVICE WE CAN GIVE. SOMETHING MERE PRICES CAN'T COMPETE WITH WE'VE A NEW "HAMALOG," THE ONLY REAL CATALOG, READY FOR YOU. IT'S IMITATED, BUT NOT EQUALLED. Discounts to dealers on most items. Use your letterhead and give references if not already established with us. We're Pyrex jobbers, 7" antenna insulators \$1.50, 12" \$3.50, lead-in bowls \$1.50, new UX tube sockets on the way; We're Belden jobbers, No. 12 enameled wire, No. 14 enameled, 7-22 stranded enameled, wire specialties of all kinds; We're Thordarson jobbers, 100 watt plate transformers \$13.00, 450 watt \$18.00, 900 watt \$30.00, 80 watt filament transformers \$7.00, 150 watt \$10.00, 300 watt \$15.00, special plate and filament transformer for one 5 watt \$7.50; We make edgewise wound copper strip of excellent quality, 6" inside diameter 12c per turn, 4" 10c per turn, straight strip 1/16" x 3/4" 5c per foot; Our own clips for flat strip, 20c; We're Allen-Bradley jobbers, Radiostats for filament transformers primary \$6.50, E-210 Bradleystat for small transmitters \$4.00, Radioleak, variable transmitting grid leak, \$5.00; We're Paradon jobbers, UC-490 filter condensers \$2.50, UC-1014 plate and grid condensers, .002 mfd. 3000 volts, \$2.50, UC-1866 filament by-pass condensers, \$1.35; We're Amrad jobbers, 4000-1 S tubes \$10.00, bases 90c; WE RENT OMNIGRAPHs, 5 or 15 DIAL, AT VERY LITTLE COST. SEND FOR THE DOPE; Ward Leonard 5000 ohm grid leaks \$2.10, with mounting brackets \$2.45; Cardwell variable transmitting condensers \$15.00, National .00023 Mfd, variable transmitting condensers \$11.50 with National vernier dial; Ballantines Radio Telephony for Amateurs, \$2.00; SPECIAL BARGAIN ON SIGNAL KEY AND SOUNDER SETS. CAN BE USED TO MAKE EXCELLENT KEYING RELAY AT LESS THAN THE PRICE OF A KEY, \$1.50; 1/16" rectifier aluminum, 75c per square foot, lead 90c; Transformer iron 11c per pound plus small cutting charge; We can't tell it all in QST. Send for the HAMALOG—not only a complete Ham Catalog, but an Amateurs Handbook. Allow for postage when you order, please, or we ship COD if you wish. Shoot 'em in! E. F. JOHNSON, 9ALD, Waseca, Minn.

HAMS, POWER RHEOSTATS! For five watt tubes, kenotrons, etc. These are sturdily built and have perfect contacts. None better. 4 ohms, 2.5 amperes. Regular price, \$2.50, our price with knob and dial, \$.49 postpaid. PENN RADIO, 1220 Pine, Phila., Pa.

TO THE HIGHEST BIDDER. ONE COMPLETE 50 WATT. TUBE, TRANSMITTER, 40 and 80 METERS. ESCO SPECIAL MOTOR GENERATOR, WAVE METER and FILAMENT TRANSFORMER. TOTAL LIST \$300.00. START IT AT \$200.00 GANG. WHAT SAY? QSO. ENSALL RADIO LAB., WARREN OHIO.

CREBE 13-119. McKenna, 30 W 65th Street, New York City.

SELL—SET OF JEWELL 0-500 MILLIAMMETER, 0-15 TC AMMETER, 0-15 AC VOLTMETER, \$16.00, 4UC-490's \$6.00, 500 WATT TRANSFORMER 110v PRIMARY, 1100-1600v EACH SIDE OF CENTER TAP, \$18.00. TAKES THE BRUTE. EVERYTHING GUARANTEED IN PERFECT WORKING ORDER. F. O. B. J. H. KRALLMAN, 1480 ROWAN AVE., ST. LOUIS, 9A00

\$5.00 NEW United States Government Aviators, Automobile, Motorcycle and Racing Leather Helmet with headphones and microphones, cost \$25.00. Postage free. Limited supply; other Government Radio Bargains. Send stamp for list. WEI'S CURIOSITY SHOP, 20 South 2nd St., Philadelphia, Pa.

92

For Sale—One good 5-10 Watt Telegraph-Phone Transmitting Set. Write for particulars. Lawrence Fleming, Huntsville, Mo.

SILICON Transformer Steel cut to order .014", 10 lbs. 25 cents, 5 lbs. 30 cents, less than 5 lbs. 35 cents, 4 cubic inches to the lb. .007" for radio frequency transformers, 50c cubic inch, postage extra. At least $\frac{1}{2}$ cash with order—balance C. O. D. Geo. Schulz, Calumet, Michigan.

FOR SALE—genuine Fada five tube neodyne sets, \$50 each, $\frac{1}{2}$ down, balance C. O. D. Brent, 44 Woodmont Ave., Bridgeport, Conn.

NEW GENERATORS, rated at 275 volts 120 watts will give 500 volts \$8, UC1881 variable 4000 volt condensers \$1.50, Bakelite 3 coil hovecomb, geared mountings \$1.50, Western Electric microphones \$1, VT2s \$4, VT1s \$2. Used generators, 50 watt direct current input, output 300 volts \$8, 500 cycle 200 watt \$10, $\frac{1}{2}$ KW \$15. SEND STAMP for list. R. Wood, 38 Way Ave., Corona, New York.

EDGEWISE wound copper ribbon, the only really satisfactory antenna inductance .350" wide; $3\frac{1}{4}$ " outside diameter 10c turn; $4\frac{1}{4}$ " 13c turn; $5\frac{1}{4}$ " 15c turn; $6\frac{1}{4}$ " 17c turn; $7\frac{1}{4}$ " 20c turn, prepaid any number turns in one piece; Geo. Schulz, Calumet, Michigan.

"MY MAIL WAS FLOODED WITH ORDERS AS A RESULT OF MY LAST HAM-AD. HERE IT IS AGAIN: ARMY SIGNAL CORPS 100-300 SPARK TRANSMITTERS, \$2.75; PARTS WELL WORTH \$40.00 COST GOVERNMENT \$47.00 TO BUILD, CONTAINS .002-5000 VOLT TRANSMITTING CONDENSER SPIRAL INDUCTANCE CLIPS IN ORIGINAL BOXES; 1000 DUBILIER .002 TRANSMITTING CONDENSERS PASS 5-AMPS UP TO 5000 VOLTS-\$1.00; WESTERN ELECTRIC 1/10 MIKE FILTER CONDENSERS—35; A FEW ASSORTED VERNIER LOW LOSS COTO COIL .001 43-PLATE, .0005 23-PLATE, .00025 11-PLATE; ALL IN ORIGINAL BOXES WITH GENUINE KURZ KASCH 3-INCH BAKELITE DIALS—.95; WESTERN ELECTRIC 216-A TUBES—\$7.50; UX-112 TUBES—\$5.95; UX-210 7 1/2 WATTS—\$7.95; 2-ATWATER KENT NO. 20 AND COMPACT BRAND NEW SETS—\$64.95; A FEW AMBASSADOR LOW LOSS SHORT-WAVE COILS—\$2.95; R. C. A. WD-11 TUBES—\$1.49; FEDERAL 100-AMP STORAGE BATTERY BRAND NEW—\$9.95; PORCELAIN V. T. SOCKETS—.15; 45-VOLT NATIONALLY ADVERTISED "B" BATTERIES—\$1.75; SPECIAL PRICES ON WESTON AND ROLLER SMITH METERS. SUPERIOR AUDIO TRANSFORMERS—.95; 5-AMP TUNGAR RECTIFIERS WITH BULB—\$19.95; 2-AMP WITH BULB—\$14.95; SUPERIOR 3000 OHM PHONES MADE ESPECIALLY FOR DX WORK REGULAR \$8.00 YOURS FOR ONLY \$2.95; FILKOSTATS—.95; TYPE 201-A TUBES—.69; TYPE 199—.69 SMALL PYREX TRANSMITTING INSULATORS—.35; SHAMROCK VARIOMETERS—.69; ACME D COIL—\$7.95; ACME \$80.00 REFLEX KIT \$43.50 ORIGINAL BOXES; MARCO VERNIER DIALS—\$1.95; .00025 LOW LOSS CONDENSERS—.35; PARAGON V. T. SOCKETS—.45; DOUBLE PHONE CORDS—.25; 0-8 DC WESTON OR ROLLER SMITH METERS—\$6.00; ANYTHING YOU WANT I HAVE. MY PRICES THE LOWEST SERVICE QUICKEST. NO ORDER LESS THAN \$1.00 ACCEPTED. INCLUDE POSTAGE NO C. O. D's. SEND CERTIFIED CHECK OR MONEY ORDER. FIRST COME FIRST SERVED." 2-CAL, 89 LEHIGH AVE., NEWARK, N. J.

Q R A SECTION

50c straight, with copy in following form only: CALL—NAME—ADDRESS. Any other form takes regular HAM-AD rates.

1AAO—H. H. Cooley, 460 Ward St., Newton Centre, Mass.

1AOA—St. George's School Radio Club, H. Churchill Op. Second Beach Rd., Newport, Rhode Island.

SAY YOU SAW IT IN QST—IT IDENTIFIES YOU AND HELPS QST

- 1BIL—E. Petit, 47 Elmwood Ave., Providence, R. I.
- 1ZA—C. E. Jeffrey, Jr., 725 Commonwealth Ave., Newton Center, Massachusetts.
- 2AML—Robert S. Haviland, Chappaqua, New York.
- 2ANE—Walter L. Hayward, 98 Franklin Ave., New Brighton, Staten Island, N. Y.
- 2AOJ—Scott A. Magness, 489 W. 123rd St., New York City.
- 2ARD—E. Lutz, 924 Summit Ave., New York.
- 2CHK—Harold Sachs, 161 West 75th St., New York City.
- 2MK—E. F. Reynolds, Central Valley, Orange County, New York.
- 3AIR—Fernand Causse, Box 81, Lester, Penna.
- 3PF—W. P. Brown, Sycamore Road, Manoa, Delaware Co., Pennsylvania.
- 5AHP—Arthur D. Tennant, Box 6, Lynchburg, Texas.
- 6AOS—Frank Smiley, 3727 No. Griffin Ave., Los Angeles, California.
- 7PL—Ralph C. Rothrock, Adams, Oregon.
- 8CHR—Charles Sage, 24 Frey Street, Rochester, N. Y.
- 8CWK—F. Kelvin Kearney, 3760 W. Philadelphia Avenue, Detroit, Michigan.
- 8DBB—Stewart Walker, East Sparta, Ohio.
- 9AWD—Fred Wright, 542 Division St., Indianapolis, Indiana.
- 9BUG—Ex 1KX-1AXQ, Dick Chase, Cragmor, Colorado Springs, Colorado.
- 9DR O'Rourke & Diehl, 2415 South 56th St., Omaha, Nebraska.
- 64YZ—A. Courtois, Ingr., Hodimont-Verviers Belgium.
- 8BN—H. A. Bimm, 346 First Ave., Pembroke, Ontario, Canada.
- 11GW—Bruno Brunacci, Via Evangelista, Torricelli No. 1, Rome, Italy.

The following stations belong to members of the A.R. R.L. Headquarters gang. Mail for them should be addressed care A.R.R.L., Hartford, Conn.

1XAQ	R. S. Kruse	1KP	F. C. Beekley
1BAO	R. S. Kruse	1OA	R. S. Kruse
1BHW	K. B. Warner	1OX	L. W. Hatry
1DQ	John M. Clayton	1ES	A. A. Hebert

BIG BARGAIN!

Model UC 1015 Mica Condenser

These condensers, rated at 7,500 volts and having a capacity range of .0002 to .001 mfd are just the thing for plate and grid blocking. May be used as well for closed circuit, antenna and counterpoise series and filament by-pass condensers. Originally listed at \$5.25.

Only \$1 Order Now! After March 1st they will be \$1.25
Utility Radio Co., 58 No. 6th St., Newark, N. J.

It's Time Now

To get that A. R. R. L. Auto Emblem more on the road every day. Send four bits for yours to

QST Circulation Dept. Hartford

SAY YOU SAW IT IN QST—IT IDENTIFIES YOU AND HELPS QST

Hams! Bargains QSA!

Get your stuff thru with this C.W. transmitter. Make your own price (anything reasonable) on complete set or any part that you need.

FOR SALE

- 1 Esco motor generator set type F-23
220 V.D.C. motor—3 H. P.
2000 V.D.C. generator—1½ K. W.
- 1 Esco motor generator set type R-113
32 V.D.C. motor ¾ H.P.
500 V. and 10 V.D.C. generator
- 1 Weston 0-250 D.C. voltmeter, bakelite case
- 1 " 0-10 D.C. Ammeter
- 1 " 0-5 D.C. " "
- 1 " 0-3 D.C. " "
- 1 " 0-1.5 D.C. " "
- 1 " 0-10 Thermo-Ammeter
- 1 " 0-5 " "
- 1 Roller-Smith 0-30 A.C. Voltmeter
- 1 " 0-500 D.C. Milliammeter
- 1 Jewell 0-2000 D.C. voltmeter with resistor
- 1 Acme 300 watt Filament transformer
- 2 UP-415 R.C.A. chokes
- 2 Dubilier condensers type AM-192 .002 mfd., 15,000 volts
- 2 Pr. mountings for UV 204 tubes
- 1 50 watt tube socket
- 2 Thompson-Levering Potentiometers, 750 ohms, .5 amp.
- 1 Jewell wavemeter pattern No. 90, 150-625 meters—direct reading
- 4 UV 203—50 watt transmitting tubes
- 3 Mullard 125 watt transmitting valve 12V. Fil-2000 V. Plate

First come, first served. Write us a letter tonight. F. R. E., 1936 Market St., Philadelphia, Pa.

QST!! Oscillating Crystals!

Attention Amateurs and Broadcasting Stations:

We Wish to Announce:

We are now able to furnish Broadcasting Stations with crystals, ground to their assigned frequency. Crystals ground to an accuracy of better than a tenth of one percent.

All our crystals are ground so they can either be used for checking the frequency of the transmitter, or can be used as a Master Oscillator in the transmitter.

Our crystals give maximum output: as high as from 7 to 15 watts of crystal controlled energy is obtained from the UV-210 tube.

Prices for these crystals given upon application.

See December and January QST for prices of crystals in the Amateur Bands.

Scientific Radio Service Company,
Box 86 Radio 3AJL Mount Rainier, Md

HERCULES
AERIAL MAST

We pay freight
Mail the Coupon

20 Ft. \$10. 40 Ft. \$25. 60 Ft. \$45.
All Steel Construction
Complete with
guy-wires
etc.

NAME _____ STREET _____ CITY _____

S. W. HULL CO. Dept. D 2045 East 79th St. Cleveland, Ohio
Please send free the full details about the "HERCULES" Aerial Mast.



The Eveready Hour

LIKE the fabled ship in which Jason brought home the enchanted fleece of gold, the Eveready Hour brings a rich treasure of entertainment to charm the harbor-homes of its hearers.

Inaugurated two years ago, the Eveready Hour was an adventure in broadcasting—an hour of connected entertainment, uninterrupted by the frequent injection of the name of the broadcaster.

Many of these programs have become famous. Thousands of letters voice the appreciation of our audience and ask for repetition of favorites. We make no requests for these letters, but they mean much to our artists and to us, and are of great value in helping us in our efforts to arrange programs of a distinctive nature and pleasing to the vast audience.

Radio has already become a highly specialized art worthy of the most scrupulous code of ethics, and the Eveready Hour represents a sincere effort to pioneer in providing the most acceptable form of radio entertainment.

Eveready programs cover a wide range of entertainment and human interest, transporting us to periods of wholesome simplicity; to barren islands where marooned sailors meet adventure, starvation and death; to battle-

scarred France with singing doughboys; to emotional heights by telling with music the stories of the seasons; and to memories of yesteryear aroused by old ballad and musical comedy favorites.

Eveready Hour begins at 9 p. m. each Tuesday night, Eastern Standard Time.

NATIONAL CARBON COMPANY, INC.
New York San Francisco

Canadian National Carbon Co., Limited, Toronto, Ontario

Tuesday night means Eveready Hour—
9 p. m., Eastern Standard Time, through
the following stations:

WEAF—New York	WSA—Cincinnati
WJAR—Providence	WWJ—Detroit
WEEL—Boston	WOC—Davenport
WTAG—Worcester	WEAR—Cleveland
WFI—Philadelphia	WCCO—Minneapolis
WCR—Buffalo	WCCO—St. Paul
WCAR—Pittsburgh	WGN—Chicago
	KSD—St. Louis

EVEREADY
Radio Batteries
—they last longer

—FOR YOUR CONVENIENCE—

QST'S INDEX OF ADVERTISERS IN THIS ISSUE

Acme Aparatus Co., The	2	Loomis Publishing Co.	80
Advance Electric Co.	60	Magnavox Co., The	78
Aero Products, Inc.	72	Marlo Electric Co.	78
All American Radio Corp.	1	Mass. Radio and Telegraph School	84
Allen-Bradley Co., The	3rd Cover	Munn & Co.	80
Amateur Radio Specialty Co.	88	National Carbon Co., Inc.	94
American Radio Engineers	88	Pacent Electric Co., Inc.	87
American Transformer Co.	63	Powerola Radio Corp.	78
Amsco Products, Inc.	74	Precise Mfg. Co.	88
A.R.R.L. Application Blank	86	Radio Corp. of America	4th Cover
Burgess Battery Co.	61	Radio Electrical Works	80
Burton-Rogers Co.	80	Radio Engineering Labs.	68-71
Cardwell Corp., Allen D.	67-88	Radio Institute of America	93
Carter Radio Co.	68	"Radio Telegraphy and Telephony"	65
Central Radio Laboratories	76	Rajah Auto Supply Co.	77
Crescent Radio Supply Co.	82	Randolph Radio Corp.	61
Crosley Mfg. Co.	65	Reichmann Co.	77
Cunningham, E. T., Inc.	2nd Cover	Sangamo Elec. Co.	79
DeForest Radio Co.	69	Scanlon, Everett	83
Deutschmann, Tobe C.	84	Silver Marshall, Inc.	72
Electrical Engineers Equipment Co.	82	Scientific Radio Service Co.	93
Eagle Radio Co.	70	Stromberg-Carlson Telephone Mfg. Co.	83
Eastern Radio Institute	82	Toaz Engineering and Sales Co.	76
Electric Specialty Co.	66	Twentieth Century Radio Co.	78
F. R. E.	93	U. S. Tool Co.	79
French Battery Co.	85	Utility Radio Co.	84-93
Gearhart Schluter Radio Corp.	66	Vibroplex Co.	62
General Radio Co.	71	Westinghouse Elec. & Mfg. Co.	81
Grebe & Co., Inc., A. H.	4	Weston Electrical Inst. Corp.	96
Gross & Co., J.	82	Wireless Mfg. Co., The	84
HAM ADS	39-93	Wireless Specialty Apparatus Co.	72
Hammarlund-Roberts, Inc.	76	"X" Laboratories	84
Hodge Optical Co.	93	X-L Radio Labs.	74-86
Benjamin Hughes Elec. Co.	82	Y.M.C.A. Radio Institute	88
Hull, Co., S. W.	33		
Jewell Electrical Instrument Co.	73		
Karas Electric Co.	75		
Kimley Electric Co.	74		
Kodak Radio Corp., The	76		

ALWAYS MENTION QST WHEN WRITING TO ADVERTISERS

Another WESTON Radio Contribution

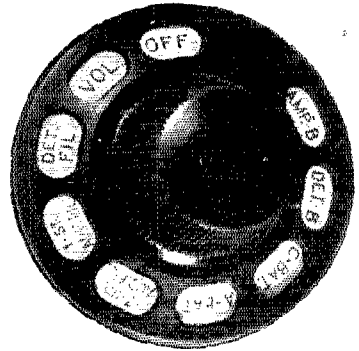
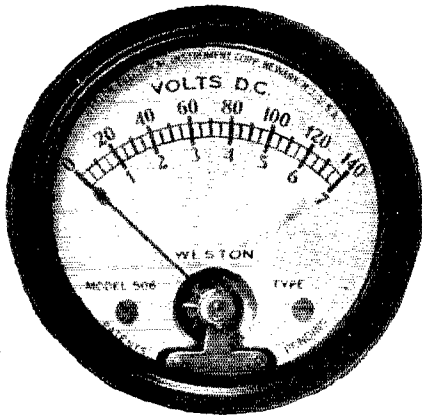

Universal Bi-polar Switch and Voltmeter

A UNIQUE combination that makes a complete electrical check of any type of radio set!

Just a turn of the Bi-polar Switch, and you can quickly and positively check all voltage conditions on the double scale Voltmeter (140-7 volts.)

Here at last is the final device that insures most satisfactory and economical radio operation, makes possible the use of tubes at proper filament voltages, checks battery conditions and gives the best results from the set. Its use on a five tube neutrodyne is typical of its application—you can quickly regulate the filament voltages of: the Radio Frequency Tubes, Detector Tube, the First and Second Audio Frequency Tubes, and check the voltage of the "A" and "C" Batteries, the Detector "B" and Amplifier "B" Batteries. Easily installed on any radio panel.

For the best results from your set do not fail to write us for full information on Model 506 Voltmeter and the Multi-point Bi-polar Switch, using the coupon below for your convenience.

Weston Electrical Instrument Corp.

158 Weston Avenue, Newark, N. J.

Please send me information on model 506 and Universal Radio Switch.

NAME

STREET

CITY

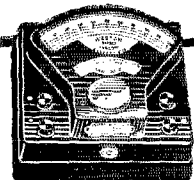

STANDARD THE WORLD OVER
WESTON

Pioneers since 1888

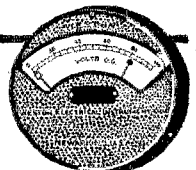

The New

S.L.F. Bradleydenser

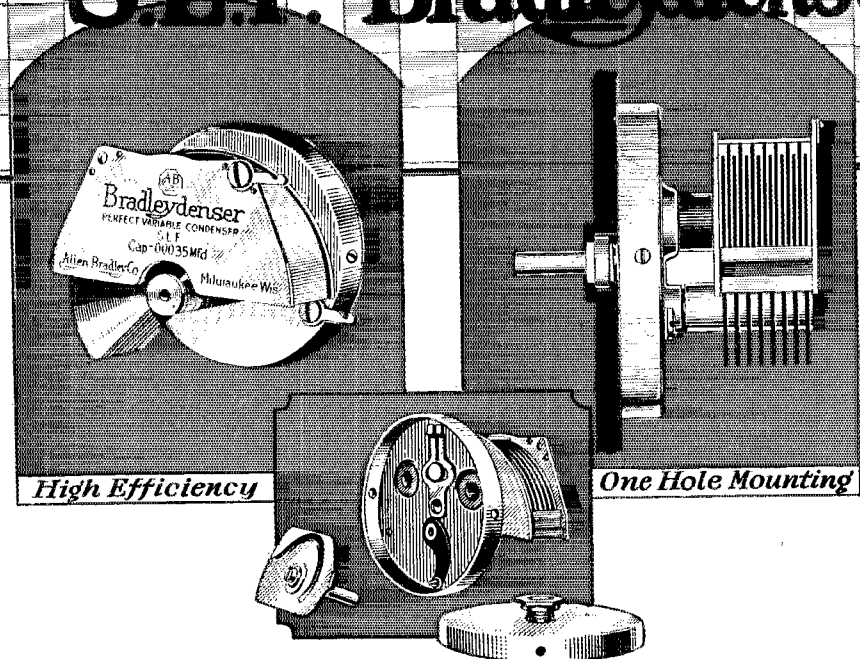

A Compact Straight-Line-Frequency Condenser

THE new S. L. F. Bradleydenser is the outcome of long, careful research in condenser design. It provides straight-line-frequency tuning over the entire circumference of a 360-degree dial. Stations are widely and evenly spaced over twice the dial-spacing of ordinary condensers. This unique control is obtained by using a special cam on the condenser shaft which provides the straight-line-frequency tuning now demanded by all set builders. The efficiency of the condenser is extremely high, due to the unique construction that practically eliminates insulating material in the condenser.

ANOTHER outstanding feature of the new S. L. F. Bradleydenser is the compact design which eliminates entirely the long eccentric rotor plates, ordinarily used with straight-line-frequency condensers. The Bradleydenser can be substituted for any condenser in a set without interfering with other parts on the panel. The one-hole mounting also simplifies installation. The S. L. F. Bradleydenser is the latest Allen-Bradley contribution to better radio. Be sure to bring your set up-to-date by getting a set of S. L. F. Bradleydensers from your nearest dealer.

Mail the Coupon

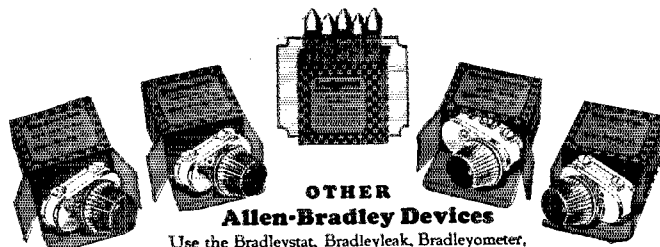

Use the Bradleystat, Bradleyleak, Bradleyometer, and Bradleyohm in your next set. For resistance amplification, use the Bradleyunit Resistor.

Allen-Bradley Company,
277 Greenfield Avenue,
Milwaukee, Wisconsin.

Please send us your latest literature on the new S. L. F. Bradleydenser and other items of the Allen-Bradley line.

Name.....

Address.....

silent power

...from your lighting socket

THE most rigid specification set for the Duo-Rectron, the new RCA "B" battery eliminator, was that it be silent—hum-free.

The hum of the 110 volt, 50 or 60 cycle line current has been filtered out by a special filter system. And the perfection of this system is guarded by minutest care in manufacture.

In many important points the Duo-Rectron meets demands never met before.

One new feature is a *voltage regulator*—a new tube that keeps plate voltages constant. The Duo-Rectron has taps for 22½, 45, 90 and even 135 volts. Hook up where you will, you get the voltage marked—no more—



no less. This means that whether you have a one tube set or a ten, you can depend on the Duo-Rectron for the correct voltage, under any current drain, all the way up to 50 milliamperes.

The new rectifying tube, Radiotron UX-213, is built for long service—designed especially for this power unit.

Everything has been considered in the RCA Duo-Rectron—silent power, reserve power, economical power, constant power!

* * *

The RCA Uni-Rectron is a power amplifier for loudspeakers. Connect it with the first audio stage of any set and get super-power amplification from an A. C. socket. Price complete, \$105

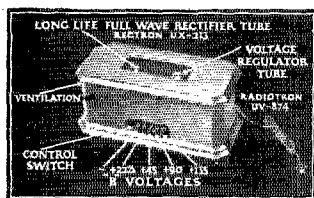

RCA Duo-Rectron, complete \$65

RCA Duo-Rectron



RADIO CORPORATION OF AMERICA • NEW YORK • CHICAGO • SAN FRANCISCO

The Traffic Department

F. H. Schnell, Traffic Manager
1711 Park St., Hartford, Conn.

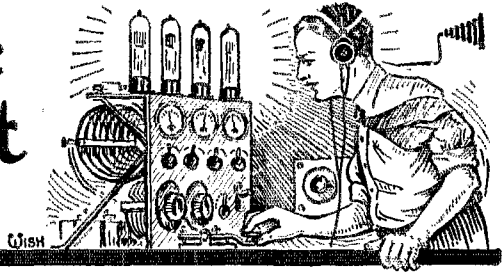

SOMETHING seems to have gone wrong out 9SE way as he failed to give us the necessary dope to list him at the head of the Brass Pounders' League although he claims a total of 869 messages. Had he given us figures to show the number of messages ORIGINATED, DELIVERED and RELAYED he would have had two consecutive months at the head of the heap and would be in a fair way to cop the T.D. Trophy. Too bad, old fellow, we would have liked to do it but we must be fair to all.

Amateurs who send in their traffic totals for the Brass Pounders' League MUST show messages ORIGINATED, DELIVERED and RELAYED—these things are required so please watch this in the future.

6BJX holds the high and mighty position this month and he certainly has been consistent in gaining his end. No small amount of pleasure goes with our announcement of placing him in the box surrounded by stars and we now do it.

E. O. Knoch—6BJX

2823 E. 6th St., Los Angeles, Calif.

Orig: 130; Del'd 40; Ref'y'd 298; Tot: 568.

There you are, 6BJX, OM—we congratulate you!

BRASS POUNDERS' LEAGUE

Call	Orig.	Del'd.	Relayed	Total
6BJX	130	140	298	568
90TK	139	103	218	460
8EU	188	7	155	350
1YC	152	77	76	305
*AYP	72	121	38	231
8BIB	9	6	205	220
*8FPG	34	22	124	180
90WH	101	12	54	167
6DX	33	15	92	140
6HUC	122	17		139
6ANO	9	4	123	136
4IB	14		116	130
*IX	109	14	6	129
2AFV	10	5	110	125
LAOX	10	23	53	116
6OI	3	12	98	113
*8RB	40	3	69	112
9DBH	24	7	73	104
*RV	80	15	7	102
6CLP	28	10	63	101
7NL	17	16	68	101
9QID	54	9	38	101
8RKV	11	11	78	100

In addition to the above, we feel justified in mentioning the following stations which should have been in the "select group had they sent in their totals as we have tried to tell them. The best we can do is list the call with the number of messages shown in the total column only: 9SE, 869; 8BSF, 335; 9DKA, 289; 9CLD, 268; 9EK, 242; 6BQ, 212; 9DAC, 157; 9DAU, 149; 8DPL, 146; 9CAA, 142; 8BOP, 134; 2CDH, 133; 8BWT, 133; 2AHK, 125; 9DKS, 125; 6CTN, 119; 2AKV, 111; 9AZN, 110; 2APT, 105.

OFFICIAL BROADCASTING STATIONS

Changes and Additions
(LOCAL STANDARD TIME)

Call	Days of Transmission		
	7.30 pm	10.30 pm	12.30 pm
8BSU	80.1 meters	80.1 meters Mon. Fri.
9CVR	38.	Sat. Sun.
4GTT
6AEP

* Wednesday at 11.30 p.m. on 52.5 meters.

** Sunday at 12.45 a. m., 39.6 meters.

WOAX	12.30 PM Tues. & Fri.	240 Meters 500 watts-Voice
3XAN	4.45 PM Tues. & Fri.	165 Meters 250 watts-C.W.
2XAN	5.00 PM Tues. & Fri.	76 Meters 500 watts-C.W.
3XAN	11.30 AM Saturday	76 Meters 200 watts-C.W.

Traffic Briefs

Persistent chap this 6BJX. During the entire year he missed only five nights of operation. Since last October he missed only two daily schedules with the Philippines due to sickness. To be sure he would be on the air regularly he took a portable set with him on his vacation. He has not changed his QRH for four months. No wonder 6BJX can be found when wanted.

Our old friend and former ADM of Maine, Dick Chase ex1XK is now 9BUC, at Colorado Springs for his health. He wants to hear from his old gang and can be reached at Cragmor.

NFU or NFW is the call assigned to the U. S. Naval Reserve unit at Kansas City, so 9RR informs us. A 50 watter is in operation. Any more Naval Reserve units operating a station?

7IF suggests a signal to indicate whether or not you are using break-in. BNK? Are you using break-in? BNK—I am using break-in. As a thought, it is high time that good amateur stations used break-in. It is a time saver and it makes for better operating—we need a good practical article on break-in. Who will supply it for QST?

7HB suggests the American Legion Posts as excellent places to scout up messages. Those of you who are looking for traffic might try this. If you want further suggestions ask 8EU—he has a patent on several ways of getting messages.

SA, OM, got a spare four bits arn'd the shack? Want to get something good for it? Maybe you don't need it, but if you've got a station putting sigs all over the globe then you will need a copy of the International Radio Call Book, gotten out by Budlong & Service and it is quite complete. But say, gang, this is a free ad for 'em so don't forget to mention TRAF-FIC BRIEFS when you place your order. Send the 50 cents to Drawer 205, Station "A" Hartford, Conn.

Enroll or enlist! Where? Why, we need thousands of amateur stations for our Army-Amateur net communication—why haven't we got your application, OM? Yes, and the U. S. Naval Reserve needs a few thousands of applications. Why don't you enroll now and get the benefit of good military radio training!

Got a bit of a scare the other night. We had the start of one of those pesky storms that cripples train service and communication. Wonder how many of you are prepared to carry on emergency railroad communication within a few hours notice. Whenever you "feel" a storm coming on, it would be a good thing to get busy lining up lanes of communications as one never can tell just when a storm is going to break. Be prepared, old fellow—you may be in a position to do a valuable service for some railroad.

It is now 10:36 A. M., January 8th and I ask you to QRX please until I can find out how many inches of wall space I can cover with the cards received in response to the Traffic Brief of last month. QRX min pse. OK here we are: The first card was received from 1APL. We have 82 cards or a total of 1476,0647* as 3BKT's card is a bit oversize. We need 12 times that many cards. 15 were received from the 1st Dist; 14 from the 2nd; 4 from the 3rd; 1 from the 5th; 11 from the 8th; and 37 from the 9th. Of course, QST was not out to the west coast and we expect more

cards. 1st, 2nd, 3rd, 4th, and 5th Districts apparently haven't many traffic men. Well, well, why so few cards. I wouldn't attempt to say which is the prettiest of so few. Wait until I get enough and I'll have a picture taken of them and let you see what they look like.

SBQW says he will bet I get over a thousand cards. Wait a minute, I'll go you one better. To the O.R.S. guessing the exact number or the one closest to the number of cards received up to and including March 5, 1926, I give him one of the original 50 watt tubes used on NRRL. Yes, the filament is ok and it perks. Do you think I'd pass out a dud tube, OM? Remember, you've got to be an O.R.S. and your guess must be in here not later than March 5, 1926.

When you start counting up your messages for the Brass Pounders' League be sure to show ORIGINATED, DELIVERED and RELAYED, otherwise you haven't got a chance at the T.D. Trophy. 9DTK says he doesn't think anybody can win it, but we don't agree with him. As 5AJT says, "there are two sides to every story—the wrong and the side." I sincerely believe I could put IMO back on the air and cop that trophy, but somebody would be sure to criticize me for it and say it was a frame-up. It would mean operating six nights a week and I'm sure I could put through 30 to 35 messages per night. We did it on NRRL averaging over a thousand per month and not short messages either. Most of them were night letters. Don't be discouraged Catel, old man!

Funny what a wild motion will do isn't it? Here I start out with a fool idea that few hams read Traffic Briefs and to test it I ask for cards to let me see how many read T. B. In one month the situation changes to the point where I am going to be minus 50 watter because I am curious to know of some O.R.S. can guess the exact number. Oh well, it's all in the game, isn't it? What is a 50 watter among hams? When I donate it I'll just go up on our roof and let this go—"Haw Haw, I just lost a 50 watter" and laugh it off.

Club Activities

Bar Harbor Radio Club operates 1BGS on 80 meters and F. M. Grindle keep the station on the air. (8750 Ks.) J. H. Sawyer, A. R. Tabbutt, C. W. Sprague

Queen City Radio Club (Brewer, Me.) gave a smoker and hamfest December 4th. Professor E. Roberts (1CNP) was the speaker who entertained a lively bunch of hams.

Modesto Radio will have something to tell about the new club house they opened January 23rd. We understand it was built from "hot-dawgs"—well, speaking practically, we mean from the sail of "hot-dawgs."

Washington Radio Club, November 28th, had an unusual meeting in which slides of 15 different amateur stations were shown. As the slide of each station was shown, the owner gave a brief description of it. Those whose stations were described are 8AB, (no station is complete without at least 5 relays—right, AB? —"ES") 8BSB, 3CDQ, 3BWT, 3JC, 3ACM, 3ASO, 3ZW, 3CKG, 3BPP, 3WZ, 3LR and 3APV.

CHECK YOUR MESSAGES

By Earle Peacox, 2ADH

FOLLOWING the general trend toward establishing standard operating practices for the A.R.R.L. we should settle upon a method of checking the number of words in our messages so that instead of having several ways of counting the words, there will be a single system that we shall all use, and it will be unnecessary to argue it out over the air every time someone really goes to the trouble of questioning the check.

We must realize that we are not obliged to use the same system that the Commercial radio companies use, since we are after accuracy and not money. In the "Cable Count," which is the system used by the commercial stations, all the words in the address, text and signature are counted and charged for. In our "business," however, the Western Union method of counting only the words in the text should

be much more satisfactory. We know that every message will have an address consisting of a name, street and number, city or town, and the state. Also, possibly the country. We are prepared to hear these parts come rolling into our "cans," and there is no need to check them, since we know that if we should find one part missing, we should go back and get it. We also know that if the station we are copying is unable to supply the missing part, we would QSK and advise him to shake down a service message to the station of origin, asking him for the correct address. Likewise, there is no necessity in checking the signature of the message. If there should be any doubt as to whether the "sig" is "Henry," or whether there is a last name, we may QSL the message by saying, "O. K. if sig Henry." The station sending the message will than either O. K. it or give you the right sig.

The A.R.R.L. operator should accept a message in any foreign language whether French or Chinese; he should not place a limit on the number of letters to a word, nor the number of words to a message, although some messages might here properly be termed "Night Letters," since it takes all night to get them off! Of course, we should always advise our B. C. L. friends to be brief when sending a message via amateur radio.

Once in a while, we run up against a hard case. If the name of a city or town or state are transmitted in the text of a message, the name of the state should not be abbreviated, and when it consists of two words, such as "New York," it should be transmitted as one word. If a word is hyphenated, the hyphen should not be transmitted (the chances are that very few would recognize it anyway) but the word should be transmitted as two words and counted as such.

If a group of figures is included in the text, each figure in the group should be counted so that there could be no possible mistake. By counting the whole group as one word, a single figure might be easily missed without that fact showing up in the check number. This would defeat our purpose.

Likewise, in case a group of figures and letters is included in the text, as "UV-208-A," it should be transmitted "UV208A" which should be counted as six words. The call of a station, such as "OA4Z" should be transmitted "OA4Z" which should be counted as four words.

Time of day, as "10.30 P. M." should be transmitted "10r30pm" which should be counted as seven words. The day of the month as "January 21st" should be transmitted "January 21st" which should be counted as five words.

This is shown in the following message as transmitted, properly checked: "msg fm yonkers ny 2adh nr 146 jan 8 r mr martin coles 156 grace street wilmington nc ck 35 hears signs of OA4Z here at 11r45pm december 22nd while he was using one UV208A audibility r5-.....sig henry ar." In this instance we follow quite closely the system used by the commercial companies as far as the words in the text are concerned. It makes for greater accuracy.

In following this method there is one small difficulty that is easily solved and eliminated if we are really willing to throw over conventional practices and follow our own system. If the check number is transmitted as a part of the preamble as we have always done, a newcomer, or perhaps a commercial "op" who is not in the habit of handling amateur traffic, would be confused, and think that both the address and the text were counted in the check. However, if we transmit the check number, for example, "ck35," right after the address and before the text, taking the place of the usual break signal, it would be clear that the words in the address were not counted, and, since the signature is separated from the text by a break signal, it would be clear that the signature is not counted either.

The thing to remember is that no one is interested in the check except the operators handling the message, and therefore, the method of checking and all the details in connection with it should be arranged to suit the operators' convenience. That is why there can be no objection to taking the "ck35" out of the preamble and using it for a break signal. Also, remember that you are not charging for the message and so a group of figures and letters readily adapt themselves to the method of counting each letter and figure into the check number instead of viewing it as a single word.

Finally, do not think we are obliged to retain old practices in operating because of "Convention" — it is what makes old maids out of buxom lassies every day.

DIVISIONAL REPORTS

ATLANTIC DIVISION

E. B. Duwall, Mgr.

INSTEAD of putting a damper on the activities in division as might have been expected, the cold weather together with the holidays, have pepped up everything in general, especially greater DX and an increase in traffic totals. However, the cold weather and heavy personal business duties has placed a hardship upon the Division Manager in keeping up with Divisional work. ORS certificates and general routine work will be in the mill as soon as the cold spell thaws out of Maryland woods. The New Year will see a goodly number of new stations sporting ORS certificates.

EASTERN PENNA.—covers a large territory with but few stations. It was found in the past that we had too many DSL's who were supervising a whole lot of territory which contained a handful of stations. The following arrangement has been made to meet the approval of those concerned, and if there are any disagreements or kicks, please let's have them early so things can be adjusted before the plans get too well under way.

Dist. No. 1 remains the same and still contains the counties of Delaware, Montgomery, and Bucks, under W. P. Lukens, 3QN. Oscar Hiskey's famous District, No. 2, has four more counties added to it, which are Pike, Wayne, Lackawanna and Susquehanna.

Dist. No. 3 will be somewhat of a combination of the old 4th, 5th and 6th. It will contain as a whole the countries of Chester, Berks, Schuylkill, (the old 4th), Lebanon, Lancaster, York, Adams, Cumberland, Dauphin, Perry and Juniata. The new 3rd will remain under the Dist. Supt. of the old fourth. Miss Bertha A. Hilton, of 3ZO fame, now operating her own station—3KO. The new district No. 4 goes entirely to 3BQ, Herb. Walleze up in Hazelton. Herb will have oodles of country to spare and the same conditions, comparatively few stations. His new assignment covers the counties of Luzerne, Wyoming, Sullivan, Bradford, Tioga, Lycoming, Columbia, Montour, Northumberland, Union and Snyder. It retains many of 3BQ's old standbys and consistent stations.

It is hoped the changes given will prove to be a betterment for all of us and help in getting reports in more promptly and stimulate more interest. The District Supts., affected by these changes are hard workers, loyal and will certainly give the territory the attention it has deserved. If all stations will report promptly, there will be no more complaints of missing reports in the traffic column. Reports from various quarters show that the matter of holding the Atlantic Division Convention has been much under discussion by local Radio Clubs and Associations but few individual votes have been received by the Division Manager or the Division Director. Individual votes on postcards or petitions from Clubs are in order. However, they must be from members in good standing in the League or from Official Relay Stations and petitions must be endorsed by City Managers, District Supts. or Assistant Division Managers.

EASTERN PENNA-ADM, 3FM—3BTA opened up with a new 250 watt transmitter, and is on the air Mon. Wed. and Fri. nites 6.30 P. M. EST and open for schedules. 3BNU working on 37.5 meters and indoor loop covered all US districts and all Canada except the 6th district, Brazil, England, BZ 1, 1A. 3CJN is the new CM at Allentown. 3UE is back with the gang. 3MQ is working on 40 meters wrestling with a master oscillator. 3BLC, getting out fine on 10 watts. 3BLP is QSO West Coast with ease. 3BTV on 40 meters has both 10 and 50 watt transmitters. 3AVM junked the motor generator set for self-rectification. 3AVL, in daylight, worked 3 French, 2 British, and 1 Italian on 20 meters. FB, OM 1 3CTZ, going strong again after a period of silence. 3BNU is QSO many foreign stations and asks all who are interested to arrange schedules on 20 and 40 and 80 meters. 3CJN blew the accumulated dust off his big jug and worked Chile, Brazil, Africa, Italy, Hawaii, Australia and New Zealand. 3AUV erected a Hertz antenna with a decided improvement in DX, reports of R8 and R9 from Europe. 3BVA has schedules with all parts of the world during his short periods at home during vacation. 3AAO is attending Poly Tech. 3EU is one of the steady contenders for the Traffic Trophy. 3CCQ low in traffic

but best in DX having worked G F. B. I. S. Africa and R. 3CFT, on 30 working a few on schedule. 3BIR, awaiting the arrival of a new DeForest "H" tube. 3BIT, on the air again with a 250. 3AFR is still hunting a good location. 3HD on schedule Tues. and Sat. from 11 pm to 1 a.m. 3ALE will be on 40 meters with a new transmitter. 3BQP installed copper tubing antenna and says FB. 3LW has worked most every country in the world and the list reported is a proud record and hard to beat. 3AHE, QRW school. 3BVQ QRW school. 3ZO has been inactive owing to changes of the transmitter. Operator B. of 3ZO, has opened up a station of her own with the call 3KO. The Phila reports are coming in in fine shape.

Traffic: 3ZM 11, 3BTA 26, 3BNU 51, 3CDN 2, 3BLC 19, 3BLP 57, 3BUV 6, 3UE 32, 3MQ 10, 3CJN 50, 3LK 4, 3AVM 1, 3AVL 7, 3CTZ 16, 3AUV 58, 3CHG 12, 3LW 7, 3AHR 6, 3BQP 6, 3ALE 15, 3HD 9, 3FS 6, 3BVZ 22, 3AWT 8.

WESTERN NEW YORK—ADM, 8PJ—Reports from Districts this month show the gang on the job every minute with traffic and schedules. Every station in full swing and all working to boost Western New York. 3ALY works British South Africa on schedule daily at 1.30 AM. 3CVI handles traffic regularly with England, France, and Germany. 3RV handles traffic with Australia and West Coast. 3DRJ works Samoa. 3ZU handles traffic with PR-4KT and PR-4RL. 3DME handles traffic with Turkey and has been heard in South Africa on five watts. 3CTH has been heard in England. 3CNX heard in France and works West Coast regularly. 3BCZ handles traffic with C2KF. 3QB works C5AW, Whitehorse, Yukon. 3BHM works Brazil, Russia and Italy. He keeps regular schedules. 3DRJ works the West Coast with traffic. 3BQK works on 5th dist. stations and NVE on a 5 watter. 3VW works midwest on phone on the 150-200 meter band. 3ADM works Australia, Italy, Wales, England, Belgium and France. 3DME received a letter of congratulations on his work Navy Day from Admiral Eberle. 3CGR works Eng-



3HG, ADM AT BALTIMORE, MD.
IS A DENTIST

land, Holland, and Australia and has schedule with G2CC and O-A6N, and A-3AD. 3BZU works at 9 pm nightly, handling traffic with Q2LC. 6AUT, NIS, 6BON and 6AK. 3HJ now handles traffic on 20 meters regularly at noon. 3ADG attended the Montreal Convention. 3DXH lost out in the brass pounders' league by one message. 3CNH handles traffic with New York City and delivered answers in less than 20 minutes. 3APO is handling traffic regularly. Stations on and reporting in regularly with traffic are as follows: 3AYB, 3ADG, 3DSM, 3BZU, 3AOZ, 3ZB, 3HJ, 3DRJ, 3HJ, 3BOK, 3DXH, 3APU, 3CNH, 3CNX, 3BXP, 3AVJ, 3ACH, 3ADM, 3BFG, 3CVK, 3CCT, 3DME, 3CTH, 3DPL, 3AWA, 3BOF, 3NT, 3RV, 3QB, 3CTK, 3UL, 3BRA, 3BQB, 3NA, 3BSE, 3OR, 3APO, 3CVL, 3ALY, 3KS, 3AFN, 3TE, 3PJ, 3BQK, 3OX, 3AUJ, 3AHG and 3CTL. New ORS appointed are 3CNH, 3DHX, 3DRJ, 3FV, 3UL and 3BLP. Syracuse has several stations on the air now. 3DKE, 3CTL, 3BIN and 3CNX. 3ACH is a new one

at Union Springs, N. Y. 80X is a reissued call, to a YL this time.

Stations in District No. 9 W. N. Y., will kindly report direct to the ADM until a new DS can be appointed. John L. Stiles, 8DDV has resigned.

After a visit of the Rochester Radio Assn. to Buffalo, it was decided to keep the two cities in the best of spirits—(Hi-DM) so the Buffalo bunch returned the visit by conferring the degree of I Tappa Key on 8AZA, 8BGN, 8WP, 8BEN, 8AFN, 8TR, 8CSE, 8DSI, 8BRD, 8KS, 8CYI and 8ALY. One member of the Rochester gang proved to be rubber skinned so a plank with nails was used and a sand paper slide constructed for his special purpose. After the ceremony, a real ham fest and supper was served.

Traffic: 8HJ 9, 8ADM 24, 8DFC 9, 8CCT 16, 8DME 40, 8ACH 37, 8ZU 69, 8DHC 99, 8CNH 16, 8BCK 8, 8DSM 19, 8AKG 20, 8CCR 40, 8CTL 6, 8HZU 5, 8CNX 88, 8QB 14, 8AYB 5, 8BHM 61, 8BEZ 36, 8CTK 65, 8DPL 146, 8APO 2, 8BSF 385, 8NT 49, 8BOF 184, 8DMZ 6, 8RV 102, 8UL 26, 8PJ 21.

Southern New Jersey, ADM. 3EN—There seems to be much more interest shown this month both in station activity and in reporting on time. 3BFH is the star traffic station. 3SJ came thru with a nice report. 3BTQ has ordered one of the DeForest "H" tubes. 3SK is a new ORS. 3DH is on the job again. 3KAN is operating on all wave bands. Code on 40, 80 and 170 and voice on 170. A 500 watt tube is used for voice Broadcast of ARRL news on 78 meters twice a week. WOAX, sister broadcasting station to 3KAN, is still pounding out ARRL information to the BCL's on BCL waves and has been the means of converting a few into the ranks. 3KJ seems to be able to hold things together single handed on the east Jersey coast. 8ALX is busy with BCL sets. 3VX reports the same. 3CO is now on 40 and 80. 3AII is having transmitter trouble. 3CGH is out of commission temporarily. 3JW worked five new Brazil stations this month. 3BO is not superstitious about his traffic totals and has his own way of corraling em. 3BWJ inactive lately on account of studies.

Traffic: 3KJ 13, 3KAN 2, 3ZI 1, 3BFH 15, 3SJ 8, 3SK 4, 3BTQ 3, 3RWJ 2, 3BO 13, 3JW 23, 3ALX 1, 3AII 6, 3CO 8, 3VX 2, 3BEI 3.

Maryland, ADM. 3TE,—although living in New York City at present returned home for the Holidays and was QSO Sweden, Italy and others on 40 meters. 3BUR has been remodeled and is kicking out FB on 39. 3PS has been appointed ORS. 3BMO is doing wonderfully well on 80. 3PH is now down on 40 and gets out exceptionally well. 3CGC wants skeds with Washington stations in the afternoons. 3RF is on

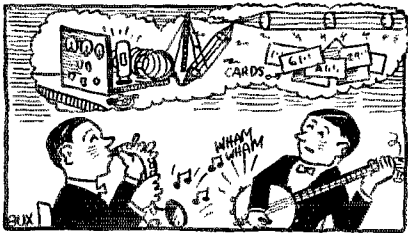

WHILE 8BPC PLAYS A SAX AND 8BCZ PLAYS A BANJO IN AN ORCHESTRA THEY DREAM OF AMATEUR RADIO AND TONIGHTS DX

40 with a UV 210 and doing well. 3APV being so close to Washington has caught the mercury arc idea. 3DW has been silent since the removal from Mt. Rainier. Ah! No time! The 3DW-3EM combination will carry an overload of antenna's this year. A single flat top, one wire for reception and 80 meter transmission, a vertical cage for the 40 meter 3EM and a Rogers Underground in the present complement. Traffic: 3BUR 4, 3CGC 7, 3APV 14, 3RF 17.

District of Columbia—ADM. 3AB—The last month has shown a definite increase in message handling. The dust has been brushed off and 3ZW is on again. 3BWT as in the past, leads in traffic handling. 3CNC has left for Charleston, S. C. 3JC is operated by the youngest member of the Washington Radio Club. 8ADS is again perking. 3IO is working all sorts of foreigners with one five watter. 3JO and 3WU have graduated to the fifty watt class. 3ACM is another station just started up with a five. 8CDQ

has at last come to her own—and a mercury arc did the trick. Her 40 meter sigs are reaching everywhere. Traffic. 3BWT 133, 3JO 55, 3AB 27.

CENTRAL DIVISION

WISCONSIN—Dist. No. 1—9DTK has all schedules working like a clock and traffic sure keeps moving. 9ATO is keeping his schedule with 9BFJ. 9ELD is operating on 40 but not pounding brass on WCZ. 9BKR is broadcasting the official ARRL broadcast regularly and would like to hear from stations who are copying him. 9BTK is getting out fine on 40 meters. 9CIB worked PR4—He took messages for New York City and relayed right away. 9AFZ is having trouble with "S" tubes. 9DOL is QRV for traffic. He handled a few this month and wants to handle more traffic. 9BWO says his storage B Bat. xmitter is getting out F. B. with a Hertz antenna. 9CII QRW

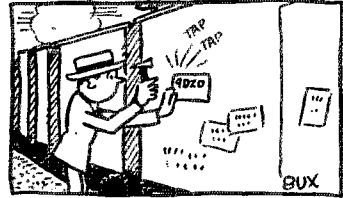

ANY OF YOU FELLOWS SEEN 9DZO'S CARDS? HE TRYS FOR QSLs BY TACKING HIS CARDS TO BOX CARS. HI!

at Marquette. 9NY has a 50 going. 9CCB Marquette University station, heard twice in N. Z. in five nights of operating in July and August. The C. M. wants to register a kick right here with all stations who fail to report, it sure is discouraging to pound and pound and not get any results. All ORS's but 9EKR, 9ATO and 9DTK's are herewith cancelled in the city of Milwaukee, and unless more reports are forthcoming, the CM may just as well resign his job for want of something to do. The CM thought that he could set the rest of the gang a good example by showing how easy a big total could be piled up, but the result seems to be just the opposite and scared the gang.

Dist. No. 2—Traffic: 9BIB 26, 9COI 3, 9ASR 3, 9EK 242, 9OM 41, 9CUO 48, 9DCP 6, 9DBV 41, 9DUJ 57, 9DLD 74, 9EAR 3.

9EK is leading the district again with 242 and wants schedules with reliable stations in Nebraska Missouri or Illinois on 38.5 or 77 meters. 9BIB comes second with a total of 220 which shows at least one in Racine is trying to boost totals. 9AZR will be on regularly. 9COL, not much doing due QRW school. A new station at Milwaukee is 9BGJ. 9OM coming up in the traffic line. Visited 9EK and got ideas for a new receiver. 9AZA has been laid up with a dislocated shoulder. 9DLD reports 74 again this month. We hand it to him for a new station. 9EAN still at U of Wis. 9EAR is experimenting with fan counterpoise on 150 to 200 meters. 9CCF is rebuilding. 9DUJ will be on regularly. 9DCP reports whether he has any traffic or not. 9DZV is handling msgs thru 9EK. 9CUO just rebuilt for UX2IO on M. G. or 2-50's in self-rectified circuit.

Dist. No. 3—Traffic: 9BVA 15, 9DKS 125, 9DKA 289, 9EMD 85, 9CIU 23.

9DKA is bundling out the traffic. Reports fine QSO in the States. 9EMD comes in for second place in traffic handling. 9CIU is going to Radio School at Valparaiso Ind. 9BVA has not been on regularly account of basketball. 9BYJ not home much so not on the air. 9AEU reports that the university of W Radio Club will have a sta on the air after the Holidays. 9ALI is president. Somerville pounds brass for 9CT at times.

Dist. No. 4—Traffic: 9AZN 110, 9DCX 50, 9AB 7, 9BKC 4.

9AZN handled 110 messages, operating schedules with 9DTK and 9DCX. The time at the key averaged just 30 minutes per day making an average of 1 message for each 7 min. Also long press messages fm LaCrosse to Milwaukee were handled for Milwaukee Journal. No time was spent for DX. 9DCX started a schedule with 9AZN. 9AB is a new station at Chippewa Falls. 9BKC handled 4. 9EIL, 9BSO, 9AKY silent this month.

Dist. No. 6—Traffic: 9ELI 11, 9OPR 3. 9ELI is back on the air. 9DPR is working nights. Indiana—Dist. No. 1—9BQE is QSO West Coast for traffic, using 10 watts. 9DEJ has a new DeForest "H" tube working both coasts on 40 meters. 9AAI has a new 50 watter, 9BKJ and 9DPJ are two new ORS. 9DUT is raising a new stick. 9DLN is still rocking the ether with a lone 5 watter. 9EG is operating 50 watts on 40 and 80. 9EJT was on a few days but blew his tubes. 9EJU is on again with some new tubes. 9DDA will be on with a 50. 9CXG going big, wants early morning traffic schedules. 9CAP is QSO all districts, but has no time for DX on account of traffic. (That's the talk.) 9EGZ has applied for an ORS.

Dist. No. 2—9DYT worked NISM and c5HP. 9BK is back on the air after a year's rest. 9DHJ wants schedules. 9BSK changed from 80 to 40. 9ABI with 10 watts is handling lots of traffic. 9OG has a schedule with Madrid. 9ACL, out of business on account if power leaks. 9CSL going good on 40 and 80. 9DLC

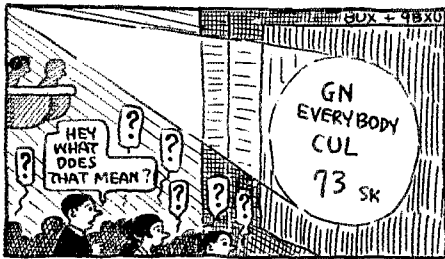

9BBD IS A MOTION PICTURE OPERATOR.

is off the air due to mast down. 9AKD going good though not much traffic reported. 9BBJ is installing a MG to run his 250 watter. 9BYI operates one of the most dependable relay stations in the district. 9AEB down due to blowing up his 750 watt filament transformer. 9ABP has no luck. His friends suggest rubbing butterfly oil on the antenna. 9DDZ going on 152 meters, will also work on 80. 9AWU handling traffic on 5 watter on 40. 9CP just installed a 204A.

Dist. No. 3—9BUB is handling traffic 7 hours each night on 80. 9BRK off waiting for "S" tubes. 9AHM reports working 600 miles on a 201A. 9HH and 9HG are new stations at Evansville. 9EBW going on very low power but getting results. 9CKH still going on 50 watts and doing his share of the traffic handling. 9BSC reports handling important traffic to his YL. 9CSC now using a small antenna working on the fundamental, but gets the same reports as when working on third harmonic.

Dist. No. 4—9DUC rebuilt both receiver and antenna. 9ADN is on all the time with two operators and a 208A. 9ES is still off. 9CUR is again working the Australians, N. Z.'s and Brazilians. 9BVZ is adding the finishing touches to a "Sync" that they claim will deliver DC (pure). 9ASJ is going again after mourning the loss of his tower for 7 months.

Traffic: 9ABI 87, 9DPJ 78, 9BYI 56, 9OG 54, 9BKJ 54, 9ADN 43, 9CAP 43, 9BQE 42, 9DHJ 42, 9CXG 31, 9AWU 28, 9CKH 23, 9RSC 17, 9CYQ 17, 9CUR 17, 9XE 15, 9CKL 12, 9AAI 11, 9EGZ 11, 9AMI 10, 9CSC 10, 9BEB 8, 9QR 8, 9BBJ 8, 9DUC 7, 9BVZ 6, 9ASJ 5, 9ADN 5, 9CP 4, 9CCL 4, 9AQU 3, 9EJU 2, 9ASX 3, 9BWI 3, 9DLZ 2, 9CJQ 1, 9CLO 1, 9BK 1, 9AEB 13.

OHIO—Dist. No. 1—8BIQ hasn't been on very much. 8DND has no luck on 40 or 80 so has gone back to 175. 8DLQ is a new ham. 8BRU is on with 20 watts, 7500 ks. 8BSA moved to 1011 Nebraska Ave., Toledo. 8AOE is FB on 80 meters. Findlay Radio Club has a portable transmitter carried on an Essex Coach, uses fone on 176 meters and CW on 80 meters. Their call is 8FT.

Dist. No. 2—8ZE worked Z, A, CH and BZ stations this month and is devoting his time to working on short wave propagation. 8CTE is working on 40 and having good luck with his transmitter. He has worked the West Coast also PR-4KT and Ber. 8AGS is working on 80. SWE still out of commission. 8DDQ is working on 40. 8PKQ is using a crystal controlled set on 40 with DC on the plates of the tubes. He worked 4 days grinding down one crystal and after he had finished it, it refused to oscillate. 8BCE continues to receive fine DX reports.

Dist. No. 3—8BKM is operating on all 4 bands from 20 to 200 meters. West Coast was worked in daytime

and a total of 81 messages were handled. Some of the message work was for the local police department. 8BNH and 8DPL still lead the district for DX. However, 8BWB has 23 countries to his credit. 8BNH worked five foreign countries in one night. 8BF and 8BGP are getting a taste of some real DX. 8DF has a new location and with half the input is doing twice the good work. We are sorry to announce that our old friend, 8BVR, has resigned as CM of Cleveland. College is taking him away from radio work.

Dist. No. 4—For the coming of good radio wx, this district has made a distinctly poor showing. Only a few ORS reported and there are a good many applications for ORS in, especially from Columbus. DX seems to be good as the ones who are on are getting out FB as witness the work of 8GZ. He is doing splendid work on low power. 8BYN has been doing very good foreign work when the power leaks allows him to. 8DEM has been doing good work for the little time he can spare from school work. 8CBP woke up to the tune of 5 messages.

Traffic: 8BKM 81, 8GZ 79, 8DBM 78, 8SI 68, 8BYN 60, 8DGP 59, 8ATX 71, 8BWB 30, 8ZE 21, 8CTE 19, 8BF 19, 1BKQ 18, 8CMG 16, 8DFO 17, 8LO 15, 8BSA 14, 8BPL 12, 8AGS 10, 8TT 10, 8ADA 10, 8PL 9, 8DEM 8, 8DRX 7, 8AOE 6, 8CBP 5, 8BN 5, 8DCB 3, 8BQI 3, 8DKW 3, 8BNH 3, 8KC 2, 8BRU 1.

ILLINOIS—Dist. No. 1—9BMD worked South Africa on a 50 watter. With the resignation of our Division Manager, Illinois feels it is losing her foremost amateur. All of us who have been so closely connected with Matty for these long years can only appreciate the many hours of time and effort he has spent to make this Central Division a leader in the League. Not only has this indomitable spirit brought this division close together, but it has welded together the League itself. Because of his executive ability, we have worked harmonically together and we can signify his effort by the now popular expression, "It started in the Central Division." So that we may have more regular ideas on the traffic reports, I wish all stations reporting would have their traffic months date from the 12th to the 12th of the months. Get your report promptly to your traffic officer so that he can report to me by the 20th. Some of the districts have shown very little activity in the past few months. Let's go now and have a 100% showing in the future from the active stations. Your ADM is also leaving you for a time. I am leaving aboard the SS Resolute from New York for a trip around the world. F. J. Hinds of Berwyn, Ill., will handle the work while I am away.



PRINTING CALL CARDS FOR HAMS IS HIS SPECIALTY

I am sure you will cooperate with him and I know he will with you. I only hope you will be willing to take me back on the job when I return.

9DKP has constructed a new 80 foot lattice mast. 9RIZ and 9BHT are back on the air with new tubes. 9BHT works on 38 meters. 9BIZ has a new set with removable coils for 40 and 80 meter bands.

Dist. No. 2—9DLO is on 40 and 78. 9DZR's best DX is Tacoma, Washington and Portland, Maine. 9RH 80 meters. He has a schedule with 9KV. 9AJM and 9ALF are on 40. 9ELR is on 42 meters. 9BUK heard Dutch "POLL". 9BRX is on 37.5 and 77 meters. 9CTF sends his report in by Western Union, "Have no traffic yet, but in two weeks will have transmitter on 40 and 80 meters. (Hey,—why have we got stations, OM?—FS.) 9RQ, dismantled. 9ARM experimenting

with LC Hartley, no efficiency. Best DX 4 coil Meissner Mass. N. J., Schnell Tuner.

Dist. No. 4—9CLZ has a couple of the new DeForest H tubes and reports excellent results. 9DQU has a new 250 watter on 20 and 40 meters.

Dist. No. 7—Ed Ohrenstein has been appointed City Manager of Chicago and has submitted a splendid report. The Chicago Radio Show Traffic helped the message report out quite a bit. Many of the Chicago gang are out after ORS appointments and as soon as they qualify they will get the certificate. In Chicago, an ORS certificate is not a gift, the fellows must work for it. By courtesy of the Chicago Radio Traffic Association, and Fred Hinds, 9APY, who printed them, a postal with return card attached was sent to each of the 425 hams listed in Chicago. This sure did help the reports to come in. Several of the old timers are coming back into the game.

Traffic: 9DWH 167, 9IX 129, 9RK 91, 9ATZ 64, 9AAE 63, 9LZ 57, 9CNE 64, 9NV 56, 9CZL 47, 9DDE 48, 9AMO 35, 9MR 29, 9DXC 29, 9DU 27, 9CSL 23, 9MP 21, 9AAN 21, 9CTX 17, 9CYR 15, 9DLO 14, 9DZL 12, 9CBI 12, 9DOX 12, 9AFF 10, 9VJ 9, 9DAF 8, 9BZ 5, 9BTD 5, 9AGQ 5, 9BHT 7, 9DYD 7, 9ALJ 7, 9ALF 5, 9AAW 5, 9DQU 4, 9BVP 4, 9CN 4, 9ATT 1, 9ELR 1, 9DS 28.

MICHIGAN—Dist. No. 1—8AMS is coming back on the air with a DeForest "H" tube. 8PF has been experimenting this month to find out which is best, 40 or 80. 8ACU has shortened his aerial and rebuilt his transmitter and is on 40. 8DBO reports that Michigan stations about as scarce as hen's teeth. 8DOO has a new UV204 tube.

Dist. No. 4—9DRR has a schedule with 8AUB on 40. Traffic: 8BWR 26, 8DOO 69, 8ZH 42, 8DRR 42, 8CWX 27, 8ZZ 12, 8DOE 10, 8DBO 8, 8PF 5, 8ACU 4.

KENTUCKY—Dist. No. 1—Carl L. Pflumm finds it necessary to resign as DS owing to the fact that other affairs are occupying much of his time. 9ARU finds he can do best work with C. P. 4 from ground. 9HP is doing good work with his big set, and is also using an auxiliary 5 watt set on indoor aerial with great results.

Dist. No. 2—9 ALM is yet working on 160 meters with great results. 9 HUD is a new station in Middlesboro. 9AMJ, of Covington, made application for ORS.

Traffic: 9ALM 21, 9HP 16, 9OX 14, 9WU 10, 9DTT 4.

DAKOTA DIVISION D. C. Wallace, Mgr.

MINNESOTA: Last month's appeals for more and better reports was answered with gratifying response. The new officials in District 3 are right after things. A few more of the fellows are showing interest in the USNRF and so far as we know a few more Minnesota fellows are now in the Reserve. FB! From the amount of experimenting going on throughout the state along various lines, we wouldn't be a bit surprised to see old Minnesota "give herself up" with something of unusual value to the amateur fraternity before long.

District No. 1—9EGU handled some special rush traffic from the Philippines, via 6RM, and worked England, Brazil, Hawaii, Chile, Australia during the past month. He handles most of his traffic on schedules. He uses a separate 400 foot antenna for receiving, working break-in nicely. 9EGF works on 40 and 80 doing considerable schedule work, and handles a nice bunch of traffic daily. 9CMS finds time to chew the rag quite a bit. He is working on a 1000 cycle audio amplifier, and is putting up a 300 foot receiving antenna. 9BMR is kept pretty busy but handles a few messages with his 201-A and B batteries. 9DKR uses 2 receiving tubes with 800 volts battery on the plate, and works all districts easily on 40 meters. 9ADS is working with a DeForest "H" tube and is on regularly. 9CWN handled a fair total but did not have time to be on as much as desired. 9EEP wants to know if the North Dakota stations have gone "under" entirely. He works on 42.5 and 85 meters. 9EGN is very QRW with school work, but pounds out as good as usual on 39.9 meters. He is the lower power wiz of this part of the country, and is sure showing some of the "Watt-burners" how to do the same on less. 9ADW works on 40 and 80 meters and gets out fine. 9DFD is in the hospital. (Sorry to hear it, OM, hope you'll be back with us again soon.—ADM) 9ADF is about to go on the air with a 250 watter again. 9BPW will

be on again. 9CKI and 9KV are now the only active stations in Duluth and both show good work. 9CDV has a new operator signed up. They operate on 87.5 meters now and work Mexico and both coasts easily.

Traffic: 9EGU 54, 9EGF 92, 9BMR 5, 9DKR 15, 9ADS 2, 9CWN 10, 9EEP 16, 9EGN 16, 9ADW 17, 9CKI 5, 9DV 54, 9CDV 11.

Dist. No. 2—9BIY and 9EBC are high traffic men this month. They are both stepping right out after everything in sight. 9SF has been heard in France and Australia. 9BNF worked New Zealand with an input on 9 watts, and is right back in his old swing again pounding out fine with his low power. 9BBV has been under quarantine so was unable to do any work. 9BFO increased his power with considerably improved results. 9MB and 9COF find traffic light, but are hammering away just the same. 9DMA now has a 50 perking and regularly as usual. 9EFD has put in a real filter, with a noticeable effect in working stations. It goes to show what a good clean note will do for distance, as well as the elimination of our good friend QRM. 9DDB blew his "radiation meter." (Gee, thought we had gotten over the idea of "radiation meters," and thought we had begun to realize that antenna current means literally nothing—ADM) 9AIR is experimenting with crystals. 9EGG received a verification on his report of being heard in South Africa while using his 5 watter with spark coil supply. 9SF and 9BFO have installed a 500 foot receiving antenna. (This long receiving antenna "fad" is getting good. Let's have some reports on ACTUAL RESULTS attained by the use of the long antenna in the different parts of the state—ADM) (I second it—F. H. S.) 9MF works with a 5 watter awaiting either a 50 watter or a new DeForest "H" tube. 9ANJ works out fine every night—has no trouble working both coasts regularly. 9MB worked Australia.

Traffic: 9ANJ 8, 9COF 2, 9CPO 21, 9DMA 10, 9EBC 26, 9EFD 6, 9BIY 49, 9BNF 20, 9EHO 12, 9MF 5.

Dist. No. 3—9DPX shot his 50 to the Happy Hunting Grounds, but with a 5'er worked 5 Aussies, 2 Zedders, and NVE at Jamaica, in one week. 9CUM works on schedules with 9EGF and 9BKV. 9BVH worked England and Brazil using the 4 coil Meissner Circuit. He is now working with crystal-control. 9DQH is back on the air again, with a 202 on 80 meters, working early mornings and evenings. 9DWO on 40 with a WE 50, and handled a rush message to NKF from PI-IHR, thru 9BQ. 9DDP finds the "U" a little stiff if he is on the air too, so does not get on very much. 9DGE uses a 50 watter with S tubes. 9BXV mourns the loss of his 5'er but keeps

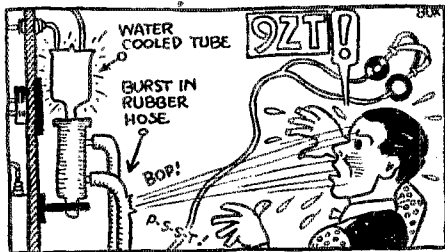

WHY THE CW AT A PROMINENT U.S. HAM STATION SUDDENLY "DAMPED" AT 2 A.M. MAY 10 TH WHILE CALLING GZKF, A2DS, ZZAC AND NRRL ON 40 METERS?

right on. 9SE is sure out to bring the Traffic Trophy to Minneapolis. Another awful wallop of good traffic again this month. 9BNK and 9ABK are both using the Zeppelin type antenna as described in June, 1925 QST, and they report wonderful success, it having solved their 40 meter problems. 9BMX finds a little time to tickle the brass. 9ZT worked Europe every night in November, and to date has worked 25 countries. 9ABK is the new DS for this district, and 9SE the new CM for Minneapolis. They are right with you 3rd district fellows, so cooperate with them in every way.

Traffic: 9CUM 49, 9SE 869, 9GH 2, 9CRZ 17, 9DGE 74, 9DEQ, 9, 9BMX 5, 9BXV 19, 9DWO 14, 9BVH 10, 9ABK 12, 9DAO 5, 9BNK 5, 9DQH 4, 9DDP 1, 9ZT 31, 9XI 10.

SOUTH DAKOTA—9DBZ has new "S" tubes and reports hearing NRDM. 9BKB's fivers went soft and he is rebuilding while waiting for new ones. 9DGR sticks to some good schedules and is doing fine work. 9DXR did good work while on. 9DAJ has been appointed ORS. 9DZI had a rectifier go bad in the middle of a good run of messages. 9NM gets good DX with a 201. 9BDW and 9DBF are starting a radio shop in Milbank. 9CJS has the DeForest doing its stuff. 9AKL is a new station at Watertown. 9BBF switched over to RAC on the fifty and blew all the haywire the first crack. 9BBR, 9DXR and 9CJS ran a couple of tests on 75 meter fone with very good results. 9CVH is coming to the front with low power.

Traffic: 9CBF 5, 9BDW 8, 9NM 16, 9DZI 46, 9DAJ 5, DXR 18, 9DGR 59, 9BKB 8, 9DBX 35, 9BBF 5, 9CSS 88.

NORTH DAKOTA—An election is being called for the new ADM in North Dakota. The present ADM found himself too busy to properly conduct his duties. The only report which came direct to the Division Manager is the one from 9AMP who has been handling some important rush traffic, ordering goods from Chicago.

Traffic: 9AMP 16.

DELTA DIVISION B. F. Painter, Mgr.

FOR some unknown reason, things have taken a slump in this division. There are certain stations that continue to do their usual fine work and they can be always relied on. We take pleasure in awarding the Donors for this month to the following: 5AKP, June W. Gullett, Meridian, Miss. A certificate of Honor and one silver star for the greatest originated traffic for Nov. 15 Dec. 15th 49 messages—4IB, Wm. Van Dyke, Chattanooga, Tenn. One silver star for the greatest total traffic Nov. 15th to Dec 15th. 180 messages. If you have not received your copy of the Delta Division Honor System, write to the DM.

TENNESSEE—4FP is still working his 5 watts. 4EE is doing his work during the daytime. 4FX is working on the Army Amateur business. 4UV is on spasmodically. 4GL is working a broadcasting station. 4HE is now in this city and on the air.

Traffic: 4IB 180, 4FP 5.

ARKANSAS—5AGN has been sick in bed. 5ABD has been on the air but gets no traffic. 5AIP has trouble getting his 50 to work. 5AW is also having trouble with a poor location. 5HN was heard in Guam. 5ANN is still working hard. 5WM is trying to come back. The Arkansas Radio Operator's League was organized in this state. Harlie Brizdell, 5QH, President; J. L. Bradberry, 5HN, V. Pres; Donald McIlwain, 5ABD, Sec-Treas. 5WK at Blythville is one of steady stations.

Traffic: 5QH 4, 5ABI 26, 5AQN 2, 5WK 23, 5AEV 10.

MISSISSIPPI—The Miss gang must snap out of the dragging way it has of reporting traffic and come to life. 5API is trying to make his transmitter perk on 40, and he is the proud owner of a Schnell tuner that does its stuff. In the traffic contest held by the Meridian Club, 5ARB won first prize, 5AKP second and 5QZ third. 5AGS changed from harmonic to fundamental on 40. 5ARB has remodeled.

Traffic: 5AEV 30, 5AFV 24, 5ARB 33, 5AKP 71, 5QZ 17, 5AGS 4.

LOUISIANA—5KC has moved from Plaquemine to Sebatobia, Miss. and will be heard from there. 5ML is building a new set to work on 20, 40 and 180. 5AGJ tops the Shreveport bunch this month. 5WY hasn't been doing much lately. 5AKI has a 50 watt fone on 180 meters. 5IC has a ten watt set on 180 meters and is using fone. 5QJ has just been made an ORS.

Traffic: 5ACY 16, 5AGJ 5, 5UK 7.

HUDSON DIVISION E. M. Glaser, Mgr.

2CDH leads the division with 183 messages and is followed by 2AKH and 2AFV both with 125.

However, 2AKH is the only one who sent in his messages to the DM to be checked. We don't know if the others are OK. Stations handling over 100 messages are to send them to the DM for checking. Many stations don't know how to handle messages and many don't know how to number them, so, to

get on the list of brasspounders in QST, the messages must be checked by the DM.

A cleanup campaign is well under way to cancel all the ORS not strictly living up to the requirements. Watch your certificate, OM if you are not doing all you are supposed to do! All CMs and DSs who have not yet done so are hereby urged to send in lists of ORS not meeting their requirements, and also to send in a list, every month, (with their report) of ORS not reporting! Please, OMs! Stations are requested to get on as many wave bands as possible. There is a lot doing on 170 and 20 and plenty on the other bands intervening. There is also plenty of traffic on ALL BANDS.

E. M. Walker, Jr. DS No. 2, N. J. is getting busy rounding up his stations and getting the best ones for ORS. Herb Ammenhuser, ADM Eastern N. Y. is also doing fine work getting things going full force. He was the only ADM to get in all the requested information about rounding up the inactive ORS. FB, Herb!

NEW YORK CITY—Manhattan is certainly picking up with Harold Sachs at the helm. His report is improving every month.

BRONX—2APJ is a new station. 2BQL has been recommended for an ORS. 2APV-ex2BEE is still working lots of foreigners and handling some foreign traffic. 2BBX has been heard five times in Germany and was complimented by Admiral Eberle on copying NRRL on Navy Day. 2BQL is getting in on the Traffic handling stuff. 2CVL blew his bottle but got another. 2CVX returned home from the road. NPM reports him R7. The YL is at the key every afternoon. QTC? 2ALL is a new station.

BROOKLYN—(Reported by the DM) 2PF doesn't get much time on the air but does a great deal of other "ham" work. 2BO is putting up a Hertz antenna. 2WC is using a crystal transmitter on the 80 meter band. 2CLA is going on 40. 2UD has a new mast up. About a dozen phone stations are on the air on 175 but none of them seem interested in traffic. 2BRB has worked all over the world using an "H" tube with 100-150 watts input and DC on 40 meters. A 250 watt (now 2 years old) with 150 watts input is working on 80 and 100 watt master oscillator (CW and phone) is working on 174. DX work is no longer being carried on as the DM has all he can do to keep track of the Hudson Division stations.

MANHATTAN—2CHK, returned from the Montreal Convention with a WE 250 watt that he won up there. Who wouldn't have gone for a 250? Hi! 2LD handled a lot of love-sick ops' messages from the navy stations. 2KR is working on Zenith



receivers. 2AMJ was hit by a motor truck and has been unable to go to work. 2EV worked a station in Sweden, the first foreigner. 2BNL is using a 300 volt storage "B" battery for plate supply. 2KW is going with 450 watts input to an "H" tube; DC with the generator hum mixed in.

RICHMOND—2ACZ is getting lots of DX cards using a ten watter. 2AKK has a very nice note on raw AC. 2AKR is a good station, except for his method of calling CQ! 2CEP is making good use of a new 50 which is being used on 170, 83, 89 and 22 meters.

Traffic: 2APJ 10, 2APV 43, 2BBX 40, 2BQL 20, 2CVL 33, 2CVX 74, 2GKH 16, 2BNL 22, 2ALS 5, 2EV 22, 2AMJ 80, 2KR 8, 2LD 12, 2CZR 6, 2FK 21, 2HJ 23, 2LM 37, 2CHU 47, 2BOX 6, 2BSL 2, 2AEP 20, 2AVE 2, 2AFV 125, 2ACZ 22, 2AKK 41, 2AKR 32, 2CEP 52.

EASTERN NEW YORK—Dist. No. 1—2BPB works 20, 40 and 80 meters and can change from one wave to the other in about 30 seconds. 2CLG still keeps relative of a sick young lady in Porto Rico posted on how she is getting along. Has also worked A-ZDS. 2AV has been rebuilding for 40 meters. 2AIZ has been operating at sea most of the month. 2AKV works all districts regularly with a UX210. 2AJE has been recommended for an ORS. 2GY is working all kinds of DX. 2KX worked A-2UI and HU-6AJL.

Dist. No. 2—2AAN finally raised an Aussie on 40 meters after giving the band up for good. A Hertz did the trick. 2AG is working all kinds of DX on 40. 2AJQ bought 2CCL's German bottle and is kicking out in great style on 80 with ACCW. 2ADD is back from school on a vacation. 2APQ is another ham graduated by the Yonkers Radio Club. 2CTF is another booster for WE 50's. 2DD is having trouble with a plate supply but is getting along. The DS got his old call, 2ADH, back.

WHITE PLAINS—2CNS gets reported R7 in England although he is only R3 in Yonkers on 401 2AAZ has no time for life but seems to handle a snag just the same. The YL's must be after 2BQB again.

POUGHKEEPSIE—2COV is the old stand-by and can always be relied upon. 2NW is rivaling 2CNS for the honor of being the district's youngest operator.

HOLMES—2APT's time is limited but has a big report just the same.

NEW ROCHELLE—2LA is having lots of trouble getting started.

Dist. No. 3—CDH did some good traffic work this month and is a candidate for the Brasspounders' League. 2BM is QSO Europe regularly using a 50 watter. 2CYH has been operating on 20, 40 and 80 meters. He has a schedule every night with 2AFV. 2CTH is doing fine work on 20 meters being QSO the West Coast at noon. He is also doing good work on 40 meters. 2ANV is a new station. 2AGM is still waiting for his motor generator. 2CUL will be on the air soon with his very low loss set, using glass panel and pyrex throughout. 2ANM is on 37, 40 and 20 meters and did some good DX working Australia and New Zealand.

Dist. No. 4—2AKH is the star traffic handler. He did all his work with a 201A and 120 volts of B battery which sure is great for that low power. 2CYM is moving his set to his home. 2AGQ has been handling some DX traffic with several foreigners. 2AUO is going to rebuild a la 2BBX. 2AI is still sick so is not on the air. 2AOX has a fifty perking on 80. There is a new station at Central Valley who looks promising. His call is 2MK.

Dist. No. 5—2ADM is using a Hertz antenna. 2CGH is still doing good work. 2AWF is pretty busy these days with his radio business. 2BSB will be on the air with two 50 watters. 2CGJ is doing good work with his big bottle. 2BXW is busy at school. 2GK has been QSO the world for past couple of months. 2PV finally got the old bottle working on 40 meters.

Traffic: 2GY 29, 2AJE 36, 2AV 42, 2CLG 5, 2AIZ 29, 2BPB 10, 2AKV 111, 2AAN 35, 2AG 38, 2AJQ 4, 2AAZ 23, 2APT 105, 2CNS 8, 2COV 6, 2CTF 15, 2DD 2, 2ADH 1, 2CDH 133, 2CYH 36, 2CTH 16, 2BM 15, 2ANV 3, 2ANM 11, 2AKH 125, 2CYM 9, 2AUO 6, 2AGQ 25, 2CGJ 10, 2ADM 91, 2CGH 15, 2GK 12, 2PV 4.

NORTHERN NEW JERSEY—A request is made by the ADM that all stations reporting enclose with their report a note of their radio activities so same can be mentioned in this column. Several complaints have come in that stations did not see their activities noted and upon investigation, we found no mention was made in their reports. 2CJX is again heard on the air altho business pressure is heavy. 2ARB, 2BIM, 2ADU, 2GYV all had the same report which was, "WHERE IS THE TRAFFIC?" 2WR has constructed a set for locating power leaks. 2ZB is maintaining a daily schedule with 8XAN and will accept all traffic for Trenton. 2AFG is now rebuilding for 40 meters. 2GV is doing excellent work, in both transmission and radio club organization. 2ALB is operating on 80 and 175. 2ARI is a new station on 80. 2AHU is another new station. 2LZ with a liver, is staying on 80 and 175. 2KA has a new QRA. 2ARL has promised not to abuse the signal "CQ" as requested by the gang. 2KS is QSO all amateur waves and has two trans-

mitters for immediate service. 2AHK worked the other coast 20 times this month with a 1KX210. 2EY is still operating on the high waves and is only heard occasionally. 2BW, our DX'er, worked South Africa, Italy and Brazil. 2BBH has developed trouble in his transmitter. Bayonne is stepping to the front with 2CRP at the reign. A new station in that city is 2BWA. 2GY is setting a fine example in traffic handling. 2AOB had the unfortunate luck to burn out his only liver. 2CQZ is QRW a YL and expects to have 2AEK and 2ARO pound the brass at his station. 2AEY has been spending his time on 80 and will drop to 40. 2QS reports Plainfield all busy "doing other things." 2AMB joined the USNRP and is operating a cutter, which is docked at Perth Amboy. 2DX has completed a new 40 meter transmitter. 2BZJ is away at school. 2CXY is now using a Hertz antenna and received a report from N. Z. 2CGK is laid up with a broken leg sustained in a motorcycle accident. 2BGI has a new 250 and is QSO the world. 2CPD never fails to lead in traffic handling. 2AUH has installed a 250 watter and when the lights in the house do not light up, manages to work Europe with ease! 2FC reports working Canal Zone 99X.

Traffic: 2CTZ 61, 2AT 18, 2CGB 25, 2CXE 6, 2CJX 11, 2CVF 4, 2CY 19, 2CRP 19, 2BW 2, 2EY 2, 2AHK 23, 2KS 2, 2ZB 37, 2CDR 10, 2AEY 22, 2QS 5, 2AMB 12, 2CQZ 22, 2CPD 28, 2CXY 8, 2FC 3, 2AUH 28, 2EG 2, 2ARI 18, 2ALB 18, 2AOC 1, 2CV 19, 2BSJ 3, 2ARL 16, 2AHV 19, 2FM 7, 2SY 6, 2AOB 4.

MIDWEST DIVISION

P. H. Quinby, Manager

DURING the holiday season, traffic has taken a considerable jump but in spite of this traffic figures are comparatively low because some of the most regular stations did not report on time. This is unfortunate for those stations as the Army Amateur appointments are being made in favor of those stations who report their traffic regularly and on time. This is the time of the year when Railway Emergency work is of increased importance. All stations are requested to keep an ear cocked for PRR, and stand by to assist whenever possible.

KANSAS: Kansas City seems to be going rather slow this month. Our old standby 9BXG is now the chief operator at WDAF and isn't on the amateur waves so much. 9DNG worked all continents this month and made a grand showing. He uses a 50 watter with 300 watts input. 9AEY uses 100 watts on 20, 40 and 80 meter bands but is on 40 most of the time. 9CVL has heard 20 South American stations in a week, also O-A5N. 9DBH has new 8 tubes and a Hertz antenna. He worked G2SZ and Z3AD this month. 9CFI is on with a new 40 meter set. 9QW and the same old school QRM. 9AOD says school work keeps him away from his set but he was QSO South Africa and Aust. N. Z. during the month. 9BRD managed to get in 14 nights of operating in spite of school. 9CCS wasn't on as much as usual so no DX and few messages.

Traffic: 9DBH 104, 9DVL 30, 9AEY 6, 9AOD 7, 9DNG 13, 9EHT 3, 9KM 68, 9BVN 12, 9CFI 3, 9BRD 8, 9CCS 2.

MISSOURI—Dist. No. 1—Traffic is much better this month with 9BEQ*PW leading the procession. 9ZK is getting out well and handling traffic. 9DMJ has been busy with BC stations and not as active as he was. 9DCW, 9BHI, 9DLB, 9AOT and 9NC take notice and report or out comes ur ORS.

Dist. No. 2—9AOB lost his 250 and is going to try an H tube. 9CYK tried a schedule with 9DAC at Lincoln, Neb., but ND account regular reception impossible, on 40 M. 9CYK-9CKS worked a 250 during holidays with 4600 on the plate. 9AYK reports 150 meters going well and 80 crowded. Another transformer went west at 9AYK. 9BRU, rebuilding. 9CDF reports two new hams in Butler. 9DVF is doing FB with 201A, being heard well in daylight at 9DAE. (Same here,—ADM). 9DAE is still having his troubles with a key that got hot and burned a hole in the table. 9DNJ is on 175.5 with phone and 83.4 CW and handling some traffic. The following appointments are cancelled: 9DAD as ORS and CM in Sedalia—no reports. 9RT as ORS and CM in Columbia—Report for Nov. 10 days late. NG, and no report for December. 9DRM is going again and handled a wad of mssg. 9CRM comes in louder at the ADM station in daytime than at night. He

has a schedule with 5ATA at noon and 9EFE in the early evening. 9DX is on with 5 watter but has QRW from school. 9HVK was home for the holidays. 9DZO is still op at WVAR. 9CMI is still building the station.

Dist. No. 3—A good hamfest was held early in the month at 9BSH. Several hams from the extreme SE parts showed up driving 85 miles. An Illinois ham across the river was present. It is intended to hold these meetings once or twice monthly. We presume the S. E. Mo. Radio Assn., is doing this. 9DWK is on some. 9BSH and 9BDS report ND this month QRW biz. 9EEH comes to bat again to save the report with 31 msgs. Hurrah for 9EEH.

Dist. No. 4—9ACX is back again with a 210 on 40. 9ELT has a 203A and reports DX good. 9TJ is trying to get a replacement on a 210. 9RKK is running the ham column in the Sunday K. C. Star. 9BKO is on at times on 40. 9WV is a new station with a 5 watter. 9DOQ QSYd to 40 and 9DEJ is going again after long absence. 9RR is sticking on 80 and handling traffic. Schedules are in effect with 9BFG and 9DXY. 9FF is back with the 250 and 4000 volts B battery, thanks to KLDS. 9EEZ led in traffic and still works NZ. 9BND ordered an H tube. 9BDB is a new station in this month's score. 9CZW is still active. The K. C. section of the USNRF have a temporary set up with 50 watts signing NEW. A larger set is to be used later. SWLs should be sent to 9ZD or 9DRD for the time being. Several locals have volunteered for the Army Amateur work and several are interested in the USNRF.

Traffic: 9EEH 31, 9ZK 36, 9BEQ 74, 9DMJ 15, 9DXN 10, 9DVF 18, 9CDF 5, 9AYK 4, 9AOB 32, 9CRM 52, 9DNJ 9, 9BUE 8, 9BKK 47, 9RR 98, 9TJ 18, 9ELT 50, 9ADR 15, 9FL 4, 9DRD 8.

NEBRASKA—Dist. No. 1—The traffic reports for the month by no means represent the amount of activity in this district, for there are many stations active in Omaha and northern Nebraska, who have not reported. It is essential that the reports from these stations reach the DS or CM by the 15th in order to appear in this traffic column. 9BFG is on most consistently and takes first traffic honors. He has schedules with 9AJW, 6AOS, 9BKV, 9AQB, 9AOL, 9EBL and 6CTN, using WE 250 watter, on 30 meters. 9DXY is on three nights a week and takes second traffic honors. He has schedules with 9CDB, 9BKV, 9CAA, 9RR, 9DOA and 9QD, using two 201s on 80 meters. 9NL is getting good DX working Mexico, Cuba, Hawaii. He uses a 203 on 40 meters. 9DPS, 9CIM and 9BYG report little activity and no traffic. 9BYG and ex-9HT have combined and built 9DR. 9EBL is very consistent with 50 watts on 80 meters.

Dist. No. 2—DX in this district is as good as usual. 9DAC is QSO NZ and Australia with a fifty and leads with traffic this month. 9DI has much better report this month, due to maintaining schedules. 9PN is a regular this month and doing some very commendable amateur work in wiring up the Hospital at Syracuse so the patients can listen to broadcast programs. 9EAK has had little time during the past month. 9CGQ is handling traffic on 40. 9BOQ has good message report for the month. 9AKS is on the air on 40 and 80. He is CC for Lincoln as well as DS. By a series of test messages, this division is being scanned to find the best all around stations to get the Army Amateur appointment. Application for consideration should be made as soon as possible to the DS, Mr. H. Spener, 2511 "R" St., Lincoln, 9ATL is attending the Univ. of Nebr. 9ANZ is on 40 with a new DeForest "H" tube, and says they are FB. 9AML is hard on 50's so is going back to 5's. 9CGL and 9ANY joined the list of married men this month.

Traffic: 9DAC 157, 9DI 47, 9CGQ 12, 9BOQ 24, 9AKS 8, 9NL 48, 9BL 65, 9BFG 180, 9DXY 140.

IOWA—Traffic is moving fairly well throughout the state. 9CHO and 9EKX are consolidating. 9BKV is the star traffic man this month, while 9DAU is a close second. 9BKV has several good routes in all directions which accounts for his traffic. 9CZC is handling traffic on regular schedule, and uses a break-in system. 9BOS and 9DWE have consolidated and are using a 250 watter. 9REW is remodeling and arranging new schedules. 9DMS is on the air in the early mornings after work at KOIL. 9EBX and 9BX made application for ORS. The Des Moines gang are active, and 9ACH makes application for ORS and City Mgr. 9ACH reports DX to be fine, with every ham active with power from five to fifty watts. The Capitol City Radio Club is making itself useful by constructing a "Trouble shooting set" and tracing

down line leakage. 9AXQ handled 5 msgs this month and his best DX was both coasts on 80 meters. 9CGW reports his best DX all districts except 6th and 7th on 5 watts. He reports 8 ham stations in Keokuk. 9HK handled 8 msgs—(Were afraid he is falling for some girl) 9DOA has schedules with 9DXY, 9BKN and 9DYL. 9DNF handled 64 msgs and has schedule with 9BP at 11 AM each day. He has 50 watts on 41 meters and works at WBBM. 9CGY reports schedules kept with 9ALL and 9DTO. 9DAU uses a wave of 40 meters and his best DX was Canada, Cuba, Calif., Washington and England. Schedules were kept with 9DWH during the radio show. 9ASR is a new stn and is operated by one of 9DAU's ops—Chief op at KTNT. 9DSL reports his best DX was PR,—4UR and Q2JT. (9DSL's set is installed in the shack of Ex 9BHC and is using 2 operators). 9BPF has been operating and handling t/c at 9LC. 9LC has temporarily closed down for the Xmas vacation as all ops are gone. 9CXX reports direct. He used two 204A's on 27½ meters, keeping schedules with Z4AG and BZ1AC, also working many A's.

STOP! LOOK! LISTEN!—All ORS are requested to send in their reports before the 15th of each month to their respective District Superintendents. This must be in on time if you expect to see your station represented in QST.

Traffic: 9DAU 149, 9BKV 207, 9AXQ 5, 9CWG 5, 9HK 8, 9DOA 28, 9DNF 64, 9CGY 10, 9CS 2, 9DSL 54, 9CVF 25, 9BXR 2, 9LA 75, 9AZU 7, 9AVX 10, 9BZU & 9ACH 10, 9BX 4, 9BOS & 9DWE 9, 9CZC 36, 9DMS 15, 9LC 20, 9CXX 7.

NEW ENGLAND DIVISION

T. F. Cushing, Manager.

THE past month has been a wonderful month for traffic. Poor routing and not keeping regular schedules account for many delays. The routing of test message No. 110 originated at Cambridge, Mass., addressed to Hanover, N. H. is a good example, and the route is given by cities: Cambridge to South Portland, Me.—So. Portland to North Adams, Mass.—North Adams to Boston—Boston to Hanover, N. H.—time six days, touring New England! Although five out of six "Prize Test Messages" reached their destination OK, there was no time faster than mail or near as fast made by these messages. 1EF reports that he forwarded one to 1QM, who apparently held it about 30 days! The following stations have had their ORS certificates cancelled: 1BV, 1FB, 1AWJ, 1AEY, 1HA, 1AAM and 1KX. The last three have moved out of New England. The following stations have been granted Official Relay Station certificates: 1YC, 1CBG, 1ALD, 1ABE and 1ADW. Please route your traffic through Official Relay Stations when possible, as these stations have sworn to relay within 48 hours or mail the messages. By so doing, you will improve time made by your messages and help the ORS to build up good monthly traffic totals.

CONNECTICUT—The stations are showing a marked improvement in distance work and handling of traffic. 1ADX, a comparatively new ORS, has the honor of handling the most msgs. 1HJ handled a msg. with a station in Italy one hour after it had been filed at his station and another with a station in Holland via the same route. 1CBG reports that foreign DX is rolling in at his place. 1CKP has worked Italy, France, Holland and Brazil quite consistently during the past month. 1IV and 1AH are on when home from college 1AVX has received an appointment as an Army Amateur station and is expecting to join the Naval Reserve. 1BHM reports some real live DX work with Italy involving a msg. from the Major Gen'l. of the Philippines. 1AOS hopes to make up for lost time during the Xmas vacation and 1AYR says business has kept him from doing as he would like to have done. 1ADW has been experimenting on 40 meters but says 80 is the one for traffic. 1BGC and 1CTI report business rather quiet. 1CTI has been trying to make a 201A sound like a real noise.

Traffic: 1AOS 6, 1CKP 6, 1BGC 11, 1AVX 40, 1CBG 5, 1AOK 116, 1BHM 22, 1AH 7, 1MY 3, 1IV 4, 1HJ 77, 1ADW 18.

RHODE ISLAND—A large number of stations in the Providence division did not report this month and no report was received from Pawtucket at all. Failure to report next month will mean cancellation of ORS certificates.

PROVIDENCE—1ABE-1AGX blew his fivers and put in a 201A and worked all but the 6th and 7th

districts in one night. 1AEL is using a UX210 with 500 volts DC and works the other coast. 1ALD is another using a UX210 and getting out great. 1AFO has been rebuilding. 1PB found out that he got better results with a "bootleg" tube than he did with a regular 5 watter. 1AW hasn't been on much. 1CAB just got going. 1AWV got going at the L. I. State College with a UX210 and has worked all but the 6th district. 1BCR also has just gotten under way with a UX210. (Doggone it, the ADM is going to get one of those god blamed tubes and learn the secret of all this DX). 1BCC has been using a 201A but has a 50 on the way. 1ABP lost his Dad, OM, you have the deepest sympathy of all the R. I. gang.

WESTERLY—1AAP has been working Italian 1AS lately as well as a large amount of other DX and all on one 5 watter. 1BVB is on 40 meters to stay as DX is good and not much QRM. Doc. Helfrich will be known as 1CDS in the future.

NEWPORT—1BQD continues to be the only real active station. He is on 40 meters and is nailing DX right and left.

Traffic: 1AWV 2, 1BCC 11, 1ABP 10, 1AAP 4, 1PB 20, 1AWE 2, 1AEL 14, 1ALD 7, 1AFO 10, 1ABE 14, 1BVB 37.

WESTERN MASSACHUSETTS—1AAE had nine of the Berkshire Brass Pounders out to erect a new stick and guess the new mass was too much for the set as he blew his plate transformer two nights later. It was fixed shortly and he is again QSO the globe. Icin rewound his generator and is QSO the world again. 1VC has a bad attack of femininitis. 1ARE was appointed DS of Berkshire County. All Berkshire County Hams, please take notice. 1ARE was high traffic man for the month.

Dist. No. 4: 1BLU put up a nice new 90 foot tower one afternoon. The next morning he looked out to see how it stood the night and found that it didn't, it was down! Hard luck, OM, but don't tie the guy wires to a flower pot next time! 1IL is back on the air and doing fine work, so is 1EO. Both have started up on 80 and report traffic plentiful. 1AWW handled two Army messages during the month. 1VU has not been on much of late. 1PY back on the air strong with a DeForest "H" tube. 1BG also using one of them.

Dist. No. 6: 1AOF put a set on the air which is QSO the world. FB, OM! 1BOM is silent. He is helping out at 1AOF. 1BWN is a new station. 1CCP is doing good work on 40 after replacing a dead tube.

Dist. No. 7: 1BBP has turned to phone on the upper wave band with CW on 80. 1XZ is perking out good. 1AKZ sure is consistent. 1JE has a trick receiver in which the leads are so short that wiring was found unnecessary. 1AAL finds traffic best on

1CIT hasn't had much time to be on. 1AGS has gotten his 40 meter set going and has worked all districts but the 6th. 1ACJ has had power leak QRM.

Dist. No. 2: 1BVL is still working the same DX with his five, but is busy at 1Xm. 1OU applied for an ORS. 1RF is handling traffic but no DX. 1AIR is very QRW with DX. 1SL will soon be an ORS. 1BBM will be on again. 1AVY is very busy with BCL receivers. Another who is busy is 1BCN. 1CPQ is using two UX210 tubes and is getting out pretty well. 1YC with a staff of ops handled a good bunch of traffic, among them being some Army messages. 1BAT is getting out on three watts. 1ALP has worked his first 6, using a UX210. The short waves have been deserted by 1AYX who has QSY'd to 160. 1AXA worked 30 foreigners during week ends and 20 foreigners during four days at Thanksgiving. 1GA is working his usual DX, N, Z's, O and A sect. 1BUO worked Italy with five watts. A prize is offered to the station in Eastern Mass. handling the largest total of messages for three consecutive months, cards were sent to all ORS stations last month but so far, there has not been much response. By the looks of the traffic reports, it looks as if everyone was trying for the booby prize but there won't be one. All messages must be sent to me for checking at the end of each operating month.

Traffic: 1BBK 27, 1ACJ 1, 1BZQ 36, 1AEO 9, 1CJR 8, 1AGS 10, 1KY 28, 1ZW 11, 1BUL 15, 1OU 6, 1AIR 3, 1BEN 2, 1SL 7, 1BUO 21, 1GA 37, 1BAT 11, 1CPQ 20, 1YC 305, 1AXA 12, 1ALP 6, 1RF 19.

VERMONT—Dist. No. 2: 1FN is building a new transmitter for the 20-40 meter band, R6-6. 1APU is pounding out the traffic. 1CQM has blow his 50 watter. Hal Hal 1AC is about the only station on 80 meters. 1BIQ is at college. 1AJG has been very QRW.

Traffic: 1AC 8, 1CQM 1, 1APU 80, 1FN 3, 1AJG 14.

NEW HAMPSHIRE—1AER has a new antenna and is on every night 6.30 to 7.00 and Tuesday, Wednesday, Friday and Saturday nights 11 to 1 and would be glad to have traffic. Schedule with 1ADJ every night at 6.20. 1BFT expects to be on soon with a DeForest 50 watter. 1ATJ has changed his transmitter to KFUH style and reports it FB. Schedules 1OC every AM at 7.45 and every night at 7.00. 1AVL has built his 50 watt transmitter on 40 meters.

Traffic: 1BFT 68, 1AER 49, 1BJF 27, 1ATJ 13, 1AVL 10.

MAINE—1SO is QSO England, France and Bermuda with his 5 watter. 1COE was working a 6 station when his tube passed out. 1FM took a vacation and visited his old home in Illinois. 1CL tried 40 meters but gave it up in favor of a YL. 1BLJ is on 80 meters. 1CFO has started out with 90 volts "B" battery. 1BXH is working more stations than he can count. 1KL put in two rejuvenated 201 A's and worked 6DAA and 6HU with a plate input of only 20 watts. 1CKQ dismantled for reconstruction. 1ACO is changing to 40 meters. 1ASR is on 40 meters and handling some traffic. 1BNL has been appointed DS of Dist. No. 2. 1VF was QSO 6A3L in Kaula, Hawaii for 50 minutes on December 1st. 1BUB is getting a 50 watter.

Traffic: 1RF 53, 1KL 54, 1ATV 41, 1BIG 5, 1BDB 2, 1AYJ 73, 1VF 20, 1BNL 20, 1ABK 4, 1AAV 18, 1SO 16.

NORTHWESTERN DIVISION Everett Kick, Manager

THERE was a slight increase in traffic over the preceding month, DX seems to have to have left a number of us, but some still are burdened with it. A few changes were made in the personnel.

WASHINGTON, ADM, 7FD—7NL leads the Division for the largest total. 7UQ did some fine work, Seattle is proving to be a good relay center; keep it up. OMs, 7WQ did his bit also. 7AO-RL worked QZLH. 7WD is a new station at Ellensburg. 7RY, QRW rebuilding KFCF. 7NH reports an "H" tube coming up. Ditto 7AF. 7DC, 7GC, 7GY, 7TT, 7OY, 7FD as 7EK are all rebuilding. Seems like another epidemic. Hi! 7EN is breaking in a 50. 7JP has two coming. 7OT, 7ADQ, as 7KO are coming along nicely. 7BY is QRW school. 7KU will be on again at Seattle. 7QB is a new station at Spokane. 7NS will have a 50 before long. 7ER will be on soon with 2 5er's at Palouse. 7VL is most reliable QSR station in Spokane. 7FQ is consolidating with 7FB. There seems to be little activities amongst the Tacoma gang



80. 1ASU is using a DeForest "H" tube with mediocre results. 1DB worked 4NKF on 80 meters. 1BP finds little time to operate. 1BIV moved to Worcester. 1COH worked 2000 miles on indoor antenna and counterpoise, each 15 feet long. Traffic: 1APL 46, 1AWW 23, 1BVR 7, 1BLU 6, 1CRZ 2, 1EO 8, 1BX 6, 1AAE 51, 1ARE 74, 1AAL 14, 1AKZ 19, 1BBP 5, 1DB 10, 1XZ 8, 1BQK 2, 1ASU 8, 1VU 6.

Eastern Mass., Dist. No. 1: 1CJR says his most important traffic during the last month was some love messages sent for a friend. 1BZQ has his set perking on 40 meters. 1BBK just got his ORS. 1LM is being helped to get going on 80 meters by 1AWW. 1NV managed to get on the air a few times in spite of being very QRW. 1AEO will be on regularly.

es surrounding territory. Those being on were 7GB, 7DF, 7AIM, 7AFO, 7DK, the Radio Club of Tacoma, will soon be on using the trans. of 7AX. Ex-7AFH will be with us soon. 7MZ has a 50 going strong on 80 mtrs. The Personnel changes have been: 7GY, the new DS for No. 6 or Pacific, Wahkiakum, Lewis, Cowlitz, Clarke and Skamania. Those living in these counties report direct to him. Dists No. 4 and 7 were merged in one district being No. 4 with 7AO as DS. The counties comprise of: Adams, Whitman, Franklin, Walla Walla, Columbia, Garfield, Asotin, Kittitas, Yakima, Klhickit, Benton and Grant. Those living in above report to Kenneth King, Box 332, College Station, Pullman.

Traffic: 7NL 101, 7UQ 73, 7WQ 44, 7AO 21, 7WD 16, 7RY 18, 7NH 13, 7OY 8, 7HO 8, 7KO 5, 7TG 5, 7ABF 4, 7OT 4, 7EB 3, 7DF 3, 7AIM 5, 7VL 26, 7NS 10, 7GB 2, 7MZ 43.

OREGON: ADM, 7IT.—A new Asst. Div. Mgr. was appointed this month being Ashley C. Dixon, Jr., 1350 East 36th St., Portland, Ore. It will be sometime



7OZ was hrd in NZ on his 5er. 7HB wkd z1AX on 17 watts input. 7AAJ worked BER first night on with his 50. 7PV and 7CE are new ones at Eugene. 7UJ has been hrd African A4Z several times. He was heard by G2SZ. 7AY worked PI 1FN and 1HR. 7OK is off for illness. 7AV is working daily on 40 mtrs. 7AJQ is on at Pendleton. Ditto 7PL.

Traffic: 7AJB 14, 7AV 19, 7PP 28, 7IT 2, 7ADM 6, 7VP 8, 7EF 12, 7YK 4, 7VQ 6, 7FE 2, 7JO 11, 7WU 7, 7GJ 6, 7AJQ 5, 7OZ 5, 7HB 30, 7AAJ 34, 7UJ 34, 7AY 25, 7MF 11, 7TQ 16, 7AKH 7, 7EO 20.

IDAHO—ex7OB, ADM—7JF is still batting out traffic and working all dists. on 80 meters. 7YA is doing better traffic handling. 7QC is going strong again. He has a new antenna and is getting a new "H" tube for 20 mtrs. 7GW is on 40 meters. He and 7GX installed a transmitter at the Radio Show of their city. 7KJ ex7IU is going to the Idaho Tech. He would like to hear from those interested in picture transmission and arrange skeds. Ex7OB installed his station at 7PJ, which is running under that call.

Traffic: 7JF 25, 7YA 48, 7QC 46, 7GW 11, 7KJ 7, 7PJ 2.

MONTANA—7NT, ADM—Three new stations blossomed on the air this month. 7FC, of Butte, 7TF of Vida and 7BL of Sheridan. 7GS and 7DD are on 20 meters Sunday afternoons and would like reports. 7DD uses 83 meters for traffic. 7PU moved to Hamilton. 7EL has forsaken the ol 4rd coil supply and now uses dynamotor. 7PL tried some miscellaneous ants. 7NT still QRW winter biz. 7MX blew his tube. 7MB is still constructing his trans. 7ACI spends most of his time with his radio biz. 7KZ is operating 7IP, using 40 and 80 mtrs. 7GK reports lots of hard work at Annapolis.

Traffic: 7GS 17, 7PU 6, 7DD 6, 7EL 2, 7FL 2, 7NT 1.

ALASKA:—7DE, ADM—Alaskan Hams say that 40 meters is no good after dark so most of them will be on 80 meters until Spring. 7KN is back again on 80 meters for the winter. 7KK will be on at Juneau soon. 7SM is trying to QSY down to 80. 7FS is on 180 meters but will probably be dismantled when this is in print. WXP has a ham set perking on 80 meters which is working well. 7DE is on 80, shooting 2200 on the plate of his 203A.

PACIFIC DIVISION

P. W. Dann, Mgr. No Section

before everything will be running smoothly; please be patient and give all the cooperation to him you can. If you do not know definitely your DS to report to, send them direct to 7IT. A few changes will no doubt be made and will be mentioned later. 7AJB will be DS in 7IT's place so those in Dist. No. 4 please report to him hereafter. New ORS were issued, 7LQ, 7ALK and 7AEK, all of Portland. The active stations in or near Portland are: 7AJB, 7PP, 7IT, 7ADM, 7VP, 7EF, 7YK 7VQ, 7FE, 7JO, 7WU, 7GJ, 7LQ, 7AEK, 7KY and 7IP. 7PP handled the most traffic for the state and is probably the most consistent station in Portland. 7AJB did his share but sez he will run in the three figures next month. Hop to it OM! 7IT is quite QRW with school work, so hasn't much time to operate his 50 watt storage battery. 7ADM claims to have a "whizz" of a receiver. He held a PI ham until 10:30 AM in the morning, also heard one G and a S. African station.

A stage of RFA ahead of his set seems to be the trick. 7KY is successful in QSOing East Coast. 7VP has visions of about 6 more 1 "mike" condensers to smooth his plate supply. 7EF and 7IP are comparative newcomers on the air but doing fine work. 7EF is especially noteworthy because of his excellent operation on the air although being totally blind. FB, OM! 7YK started out by working all over the US and NZ until the ol 203 departed. 7VQ claims he can't make his set oscillate on 80 meters but we're inclined to believe a YL has something to do with it. 7FE likes 80 meters better than 40 for traffic. 7JO is another newcomer. 7WU has blown himself for a UV203-A. Ditto 7GJ. 7LQ has been using his beautiful transmitter to a good advantage. 7AEK develops a very good QSB by using about 10 mikes across the plate supply. 7EO was QSO an Army station at Honolulu. 7HV reports being ill also receiver trouble. 7AKH gets east fairly well. 7TQ has been doing swell work on a amplifier tube. 7LS has to give more attention to school work. 7MF will be going strong with a DeForest "H" tube soon.

IT IS with regret that the Manager and the Northern Section of the Pacific Division hear of the resignation of M. E. McCreery, manager of the Southern Section as the League sure loses a worker. Good luck to you, Mac, and best of 73's from all. The manager of the Northern Section wishes to thank one and all for the cooperation by all for the Year 1925, and looks forward to the NEW YEAR 1926 as a bigger and better Year for the League. 6OI and 6CLP grab the honors this month for traffic, the former handling 113 and the latter 101. 6CCY worked Indo-China using one Five watter self rectified circuit. 6CLP is handling traffic with the Philippines. 6BCL is the only station in the district using 20 meters (15000 ks) and working across many times. Best DX was c1AR at 2:30 pm, PST. Competition is nil when 6OI hits the air as he worked USS Scorpion off the coast of Trieste, Italy. 6NX tried out a pipe antenna this month with good results.

Dist. No. 6—6XBY has been busy at KFUU. 6CMG is visiting folks in Pennsylvania. 6CGG will be on the air with a new DeForest "H" tube. 6CAX is on 40 (7500 ks) now and works 6ZAC (NPU) using KFUU type transmitter. 6ALV doing his stuff works Aussies and J1AA. 6TI has returned from his round-the-world trip and will have 100 watts. 6BAA has a 50 watter already to go and dropped it. 6ZX can sympathize with you, OM., as his fifty watter went "WEST" and so ZX is off the air until ????? well, I'll never tell. (Haw, Haw!—just blew my 50. Yea, try and laugh it off—T.M.). 6VQL is using 200 watts and reports working Cuba and all US districts.

Dist. No. 6—Wake up 6CC, 6CV, 6CVS and a few others of you fellows up North and give Adams a hand.

Traffic: 6BFU 5, 6GU 18, 6IM 30, 6CLB 26, 6ALV 18, 6RJ 13, 6CAX 12, 6CMG 10, 6VK & 6WP 11, 6CMM 6, 6SL 4, 6ALK 1, 6RW 32, 6CLV 3, 6BQL 4, 6CVQ 48, 6RH 17, 6BAA 8, 6AC 4, 6CHE 18, 6BU 6, 6AIH 22, 6NX 18, 6BAM 6, 6OI 113, 6AJZ 1, 6BMW 56, 6BCL 3, 6CCY 2, 6CLP 101, 6CUX 8, 6AOI 8, 6BVY 20, 6CUR 1.

DX and traffic are now first-rate; fellows are learning the value of schedules; poor operating practice begins to abate as the gang sees through the ARRL rules.

Dist. No. 1—6RQ keeps a schedule with the Philippine Isles, it means a lot of traffic and it's 6000 miles. 6BDE uses two 5 watters and they sure do perk. 6AJM came to grief when a filament parted. Cats are bothering 6SB, they hang from his counterpoise wires, says he. 6CHX operated on 20 meters during Christmas vacation. 6HWY schedules with L. A. 6AFP blows his tubes quite regularly. 6CGC's trans is perking FB, only his jennie gives a tone that sounds like AC. 6ZH has been off for weeks, QRM from power leaks. A new ORS is 6DN; he can't be on much, 6CL's say when. 6LA is a busy man, rebuilding 6CGV as fast as he can. "I can't be on," says 6HK, school QRM. 6HU is handling traffic throughout the nation. A DX station is 6AIB, his latest is pi NUQG.

Dist. No. 2—Insure your fones, 6AE is putting in a 250. Says the report from 6AFG, 80 meter fone for me. 6ASE pulls the time worn gag that too much school induced brain fog. 6BBV will have to move, his power leak he can't improve. Its easier for 6BCS to work DX than local—yes???? Watch out for a five hundred cycle note. 6BEV's doesn't it get your goat? A fifty for 6BGV. In Guam, 6BJD is keen though not a flip on his meter is seen. 6BJX leads the gang in traffic. 6BQR's new QRA is 118 North Clark Drive, L. A. 6CAH did not report—just one more chance is on our retort. 6CSW wants to try that 20 meter lure. 6CTN is sure right there, his traffic total is a bear. 6CTO says just one mike makes the DC that we all like. And Ex-Australian 5AP is using call 6CVE, 6DAI to five meters will go, we wish him luck, but we don't know—. 6IH hears 6SZ, and also logged French 8JD. 6JI says he will now lay off of syncs forever, how? For 6RF we'll shed a tear; DX thru QRM he can't hear. "I'm awful busy," claims 6VC, hope you'll find more time to pound the key. 6RF has blown his 50. 6BBQ is on again, but his YL judgment is gone again. 6BLS does good DX, without YLs he has no wrecks. An "H" tube will soon grace the shack of 6CMQ. His fiver's slack. 6AJI is almost through, commercial, banks, and yts, too. 6CIX is kinda damp, he fell for a Whittier College vamp. 6CSS was off for weeks, he had a million power leaks. 6BUR is tearing through, England, Africa and Peru. 6CHZ is on again. 6AKW's traffics light, he doesn't do much work at night. 6CAE is getting out, he works DX we hope to shout. 6CGW's laying low; QRW? YL? NO? 6DAA has many skeds, and so he has no power for beds. 6CNE is using five, we're glad to know he's still alive. 6CGK is slow with traffic.

Dist. No. 3—Affairs up here are slowly improving; one-third the ORS has now been cancelled, leaving only stations that keep moving; no more ORS by dead ops to be held. This month will see a new DS in line, outside work given 6JI no time. The cheers this month are for 6ASV, the most consistent station in District 3. 6CWF looks for a plate transformer; who wants to be a generous donor? The rest of the stations are merely off and on we see. Well, no real activity, no publicity—in QST.

Traffic: 6BJX 887, 6BQ 212, 6CTN 119, 6CGC 30, 6HWY 30, 6AJM 24, 6AIB 22, 6HU 20, 6BDE 19, 6SB 8, 6BAS 7, 6DN 4, 6CHX 3, 6AFP 3, 6AE 2, 6AFG 23, 6ASE 31, 6BBV 9, 6BCS 10, 6BGV 8, 6BGC 35, 6BJD 11, 6BQR 22, 6CSW 32, 6CTO 91, 6DAI 50, 6IH 16, 6J 3, 6OF 10, 6VC 35, 6CAE 33, 6DAA 26, 6CHN 9, 6CGK 2, 6AKW 8, 6AJI 11, 6RN 42, 6BBQ 84, 6BUR 9, 6NW 8, 6ASV 3, 6JJ 5.

ARIZONA—6RS is a new station in Williams. His QRH is 80 meters, uses a lone 5'er, on that wave es is handling lots of traffic. On each night es wants schedules East and West. 6AAM is trying to make a 5'er perk on 40. 6BWS is trying to get a transmitter working on low power. 6ANO's power is new 7.5 watter on 40 es 80 meter band es kicking out fb. QSR ani traffic east or west ani time, gang. 6CEK is active, 6BGA at Mesa, will be going soon. 6ZZ our old friend and former ADM will be on with a 100 watter. Ex-7HU will be on air abt 15th Dec with 50 watter on 33 meters. His new QRA is Roosevelt, Ariz. Lakeside Club, F. F. Taylor. 6PZ, 6CHJ, 6CUW and 6CAP all are on 40, going FB.

Traffic: 6ANO 136, 6RS 16, 6CUW 18.

K. A. Cantin, Mgr. Hawaiian Section

For the past month, stations of the Hawaiian section have had great difficulty in the reception of 40

meter (7500 ks) mainland signals. Sixth District stations were very seldom received and stations that were heard lacked the usual "punch" and were very hard to QSO. Every station reporting for the month made mention of this "blanket effect" on the 40 meter band. It did not effect stations on the East coast of the mainland, New Zealand, Australia, South America and Africa were received with greater signal strength during this phenomenon that effected the 40 meter band. Dow, at NPU, seemed to experience the same difficulty. The Radio Club of Hawaii station, 6BUC, has difficulty in keeping the station in operation every night during the week due to the lack of experienced operators. More traffic for Hawaii is wanted—we can handle all you can give us.

6AFF, with his 50 watter, has gone after traffic and has secured good results. He was QSO 22 stations for the month, all of the stations 2000 miles or more away from Hawaii. 6AJL of Kauai keeps in contact with Australia and New Zealand. Was also QSO 1VF and 2DX. Very little traffic handled with the West coast of the mainland. 6CST complains school work keeps him QRW. 6ASR is busy selling BCL receivers and very seldom pounds the key. 6OA turned in his traffic report after two month's silence which almost cost him his ORS. 6BCG hears several stations in South Africa. One was A4Z. 6DB is on the air and gets through in fine shape. 6TQ reports the reception of So. Africa stations. All were received with a signal strength of K4, including 0-2LD, 3IJ, A4Z, and A3Z. 6TQ also has been QSO BZ-1AP and 1AB. 6CMH, 6DEL and 6DCF are keeping in contact with DX stations; 37c is the temporary call used by a station located at the U. S. Navy Air Station, Pearl Harbor, T. H., using a 500 cycle transmitter on 40 meters (7500 ks).

Traffic: 6BUC 139, 6AFF 69, 6TQ 21, 6AJL 16, 6ASR 8, 6CST 3, 6OA 2.

ROANOKE DIVISION

W. T. Gravely, Mgr.

WEST VIRGINIA—Reports show winter activity; more activity on 40 meters (7500ks); messages on the increase;—congratulations, gang! 8AMD has a swell looking set mounted on plate glass.

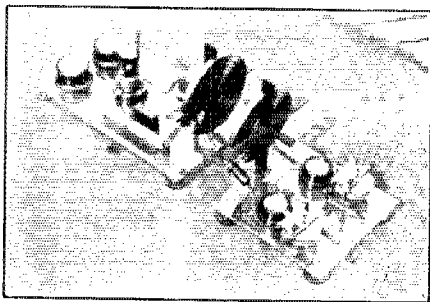

8AMD's GLASS-MOUNTED SET

Huntington seems to be the center of activity with 8ATC and 8DOI on the air. 8AYP has more trouble in shipping 250 watters. 8DBR is getting out FB. 8ALG, 8BNF, and 8CBER are new ORS. 8AYP had trouble getting a DC note. 8SP will be on soon and 8BPU may move to Washington, Pa. Glad to hear from 8CAY. 8AUL worked 6GNF and 8Z-1IA this month. 8GDV is pulling in good DX. 8BSU is in the fourth stage of Amateur Radio.

Traffic: 8YP 231, 8AUL 45, 8CDV 23, 8AMD 94.

NORTH CAROLINA—While the activities of the regulars seems to be somewhat less this month there are a number of new stations on the air to keep things going.

Dist. No. 1—The DS appointment of 4TW has been cancelled and all stations are requested to report direct to the ADM until a new DS is appointed. 4LO is active once in a while. 4OG is on at times but his job keeps him busy. 4RF is the only active station at High Point.

Dist. No. 2—4MI has discovered that the electric lights in his home are tuned to 40 meters (7500ks) and he thinks that is reason enough for his signals to be NG. (His traffic total doesn't show it, Hi—ADM). 4TS is working a couple of new tubes on lots of

Signal Corps work. 4GW found a shot gridleak in his set and is now doing good work after replacing it. 4NJ is operating a portable set at Somerville, S. C. for the winter. He worked 4VQ with one watt input.

Dist. No. 3—4RY has his set going at Davidson College and is doing some good work. 4QK is on 80 meters (3750 ks) almost every day. 4JR is working WE-50 on 84 meters (3550 ks) every night from 7 pm to 8 pm. 4TJ is just ready to start up again.

Dist. No. 4—4NT, 4NT—where are you? 4RW is doing excellent work.

Traffic: 4RF 8, 4OG 20, 4LO 4, 4MI 70, 4TS 16, 4NJ 6, 4RY 10, 4JR 15, 4RW 28.

VIRGINIA—3MK is working on 80 meters (3750 ks). 3TI has completely rebuilt his receiver and it works FB. Has heard 8BZ stations, 2 O's, 2 R's 1CH, and a flock of 6's and Pr also 2 I's first three nights of operation. 3SB has new outfit using one 50 watter which he says produces fireworks in the filament transformer. (Read back issues of QST—DM) 8AHL has dropped to 40 meters (7500 ks) and using one fifty watter. 3BS—hopelessly lost! 3CKA has just returned from another sea trip. 3CEL still tops the list the small message total. Recently worked I-1AS. Out of 41 stations worked, 14 were across the pond.

Dist. No. 3—3IW passed the month experimenting with Hertz antenna on 40 meters (7500 ks). 3RX and 3BQ have been assigned to Virginia Military Institute. 3KG works on his low power set. 3BGS without power but turned to low power set from B batt'y. 3BFE confined to his bed but is getting along nicely.

Dist. No. 2—3BMN is rebuilding. Ex-3BQ is real enthusiastic so is 3NO, altho 3NO was married recently.

Dist. No. 4—3BZ continues to hear them around the lot and works a few of them altho QRM sure cuts down a fellow's average. 3CA worked Z-2AC, BZ-1AP and PR-4JE. 3CKL works schedules with 4VQ, 3APV and 8AMD. 3DFC and 3BGP will do some work after Xmas holidays.

Traffic: 3TI 4, 3CEL 2, 3CKL 44.

ROCKY MOUNTAIN DIVISION

N. R. Hood, Mgr.

COLORADO—Denver: Stations in Denver are getting into the habit of reporting to the ADM direct instead of to the City Manager. Hereafter, unless there is a good reason for doing so, no reports will be included in the monthly reports except those reporting to 9CJY, the CM. 9CA leads the Denver gang for traffic, because he has arranged a couple of schedules. 9CAW has rebuilt for low power, but now says he doesn't like it so well. 9CDW has his set working right. 9QL says traffic is the bunk on 40. He is experimenting on 20 now. 9CJY has been very RW with school. 9EAM is on regularly and keeps schedules with 9BFG and 9BKV. 9WO is still experimenting with antennas. 9OO has a new 50 to take the place of the one that was last seen headed toward the 6th district. 9AJQ has a new way to get YL's. He calls a QST on fone on hi waves and sez any YLS tt r not QRW to call him on the line fone as it works too. Hi! 9DKM says 40 is OK in daylight but he is fr 80 or 160 at nite. 9DOG has mysteriously disappeared, but put his report in before he faded out, and sed he wd be back soon. 9FEA froze all his rectifier jars just as he was QRV to get on the air.

Traffic: 9CCA 142, 9DQG 20, 9CAW 16, 9, 21, 9WO 64, 9EAM 80, 9CDW 2, 9QL 7, 9DKM 36, 9EDF 20.

Dist. No. 1—9DVL has not handled any traffic this month. 9AOI has a new transmitter ready to go and promises more traffic next month.

Traffic: 9AOI 1.

Dist. No. 2—9CDE, the new DS is sure getting things working fine. 9BUG has applied for ORS as has 9CFY. 9ADI is a new ORS and is getting fine results on both 40 and 80 meters. 9BUG is a former ADM in the New England Division. 9EAE reports as usual. 9CDE has been looking up new hams as he travels over the country. 9CFY boasts a commercial license. 9CHT wasn't on much. 9CLD handled a fine lot of msqs but failed to send them in for checking. Next time u do gud work like that, send them in. We want to bring that Trophy to Colorado.

Traffic: 9EAE 29, 9CFY 22, 9CHT 4, 9ADI 41, 9EDE 32, 9CLD 268, 9BUG 5.

WYOMING—7HX maintains a daily schedule with 9CAA at 12.45 PM daily and reports very successful operation. Much traffic and a good route is kept open this way. 7LU is the only Casper station on at present

and reports some very good daylight DX on 40 meters. His QRA is Casper, Wyo. now instead of Greybull, Wyo.

Traffic: 7HX 28, 7LU 45.

UTAH—Things are looking better in general and we have many more reports this time than we have had for several months. The majority of the Utah amateur activity is in Salt Lake City.

Dist. No. 1—6CJB has been out of town most of the time but has been carrying on lots of experimental work and the results have been interesting.

Ogden—6FM is on 76 meters. 6SI has just been granted an ORS.

Salt Lake City—6AKM reports 13 messages. 6BTX has been doing consistent work. 6BUH has been carrying on experimental work with oscillating crystals. 6CRR has his transmitter on 39 meters but did not handle any traffic. 6CRS handled 19 messages on 41.3 meters and reports best distance worked was 05K. Also reports working A-3HL. He keeps schedules with 6CND and A-3EF. He has worked A2TM too. 6RM is on 38 meters and handled 84. He will soon have a low power station in operation signing 6ZBS. 6RV is using a 201 tube with average of 5 watts input.

Traffic: 6FM 11, 6CJB 10, 6RV 10, 6AKM 13, 6CRS 19, 6RM 84, 6BTX 65.

SOUTHEASTERN DIVISION

A. D. Trum, Mgr.

WITH this my first report, I wish to express my sincere appreciation to the members of the Southeastern Division for the confidence which they have shown in me in electing me their DM. I will endeavor to earn this confidence and lend my every effort to build up a bigger and better division.

ALABAMA—The recent resignation of Division Manager Reid and the election of A. D. Trum, as his successor has somewhat disorganized the Alabama organization during the last month. The writer has just taken over affairs in Alabama and has not as yet perfected the new organization. Another month should set things right as only a few changes in personnel are necessary.

Dist. No. 1: Things have happened thick and fast in the last several weeks. Supt. Connolly resigned and H. S. Brownell was appointed to succeed him. On the heels of this appointment, ADM Trum was elected DM and Brownell advanced to ADM for Alabama. Again the office of DS was vacant. Mr. S. K. Sawyer, 906 Fulton Ave., Birmingham, Ala. has been appointed DS. 5AX has just received his ORS appointment. 5VV is ready to uphold his old rep. on 40 meters. 5AWF can be heard regularly and is reaching out consistently. 5MI has found time to get on the air once more on the 40 meter band. 5AMH has been off the air on account of business. 5ARJ has been handling regular traffic with 5VD.

Dist. No. 2: Dist. Supt. Hurley reports considerable activity in the vicinity of Mobile. Of three reporting, 5AC leads the district with 21 messages. A message contest came to a close this month with 5AC running first and 5QK second. Activity slumped quite a bit on account of a combined attack by the feminine sex and the rebuilding habit. 5QK has not been able to make his set perk since rebuilding but hasn't given up the ship yet. 5DL is struggling to get his wave up to 40 meters. The district was honored by a visit of the Bryant Twins, of 4BL, touring around in 5QF's divver. 5AC has been handling Signal Corps messages between Mobile and Canton, N. C. These messages were of important nature. 5AC has been reported R6 in Capetown, South Africa. A total of 36 messages was handled for the month.

Dist. No. 3: This district is handling traffic in good style. The gang is together better and more cooperative handling of messages is the result. 5ATP is getting out excellent on 20, 40 and 80 meters. We still have 5AJP, the ol' reliable on the air perking at 80 meters and working everything coming his way. 5AJP carried on a series of test with the coast guard cutter, Modoc. 5ADA is gathering in the messages by the bushel as a steady result of his advertising for same. His neighbors think he is old man Western Union, himself. Hi! Hi! 5ADA deserves honorable mention for being one of the most reliable operators in this section. 5ASU is remodeling. 5DI has been to Auburn but was home for the holidays and made the station hot on the air. 5WI is at Auburn. 5ASR is getting things into shape and promises to be a good station. 5NL is working at night and hasn't had a chance to be on. A total of 115 messages was handled for the month.

Dist. No. 4: No report was to be had from this district this month but the ADM knows that 5YB is hitting the pace on the ether and making a good name for himself.

Traffic: 6AC 21, 5AAD 5, 5ADA 52, 5ARJ 10, 5ASU 5, 5ATP 32, 5AJP 26, 5AWF 14, 5AX 7, 5MI 12, 5AK 10.

SOUTH CAROLINA—The hams in this state are fine lively bunch and doing splendid work for the League. Another low power record! 4VQ with only 4 watts input was QSO Nova Scotia. This has been verified. Look at his traffic total, too. 4JV is going strong and has trained 4EG. New stations are 4AAM and 4OY.

Traffic: 4VQ 114, 4IT 20, 4RR-4VL 30.

PORTO RICO—Most of the Porto Rican amateurs who are licensed for transmission are on the air, and everyone seems to be doing his best to push real traffic through. We now have with us PR4KD of the Naval Radio Station, doing some excellent work on the low waves. 4KT has been our star station for the last two months and has given the ARRL a boost by working with New York every night handling messages for a family of small means with a sick child in the United States. 4JE, 4SA, 4UR, 4BJ, 4RL and 4OI have all been working the mainland and Europe and handling messages that are real ones.

Traffic: 4KT 52, 4JE 16, 4SA 18, 4UR 23, 4RL 7, 4OI 3.

FLORIDA—Florida has been somewhat confused on account of the change in ADMs and for that reason, some of the reports that usually come in on time, went astray and consequently were left out of this report. E. G. watts, Jr., of 4FM succeeds C. F. Clark, resigned. Watts, in the opinion of the DM, is one of the most lively fellows he has ever dealt with and there is no doubt that Florida will shine brightly with Watts as leader. He is strictly for good operating and handling of messages and if the fellows of Florida stick behind him, many a good operator will come thereof. Activity in Florida has always been excellent and operating conditions are fine. The ADM has only one district to report.

Dist. No. 4: 4VS is most active, but is endangering his ORS appointment by using a bad note. 4UZ is on quite a bit, but has queered himself with the ADM by disregarding CQ regulations. Stations who disregard warnings assure themselves of not getting ORS appointments. 4FN will be on with a fifty soon. 4OK is in working order but doesn't work much. 4FM nearly blew the diaphragms off 4VS phones by working him with medium power on a one KW bottle. 4CH is making a name for himself by working his first Europeans and sixes. He claims to have worked, e-R22EA, in Spain. Spent an hour getting the call straight. 4NE was trying to make a UX210 work last time we heard of him.

Traffic: 4VS 45, 4FM 34, 4KJ 56, 4FNO 3.

GEORGIA—Change in personnel seemed to have puzzled Morris or else the Christmas Spirit (or spirits) got the upper hand on him and he either mailed his report to Chica or it was wrapped up in one of his Xmas packages my mistake—Hic Hic. That's all right, ADM, we will let bygones be bygones but let's get in a good fat report next month all about the doings "Way Down There in Georgia." 4KL sent his report direct to the DM and sez, "My station is open for traffic on any routes that you wish. Handled 47 messages this month."

WEST GULF DIVISION

Frank M. Corlett, Mgr.

DID you notice where our West Gulf stood in the list last month—fourth in originating messages, and eighth in message total, as compared with all other divisions. Not so bad.

NORTHERN TEXAS—Reports came in better this month. 5SP handled the most traffic. He was formally located in Houston, Texas. Northern Texas Section lost a good man, an old-timer, when Mr. E. B. Frysinger (5UY) was killed in an accident near Hillsboro, Texas on December 9th. He was riding a motorcycle and collided with an automobile. 5AFU, 5JF, 5VD, 5AMZ, 5AJT, 5SD, 5AMB, 5AFH, 5VF—all reported no traffic handled at their stations. That's the stuff, OM's, shoot those reports in whether or not any traffic is handled.

Traffic: 5SP 70, 5HY 8, 5RG 29, 5LI 2, 5CV 4, 5ACL 16, 5AKZ 11, 5NW 5, 5ADD 2, 5CC 19, 5AKN 11.

XIV

OKLAHOMA—Seems like Christmas has so enthralled the "Gang" that they can only contemplate the new fangled things they expect old Santa Claus to bring them—working the old tubes hard with the hope that something will "bust" and create a necessity that Saint Nick might fill with a new "H" tube or some other such. 5AAN has great gobs of QRM from his twin Junior operators, (Stay with 'em, Pa). 5EG is a new station at Guthrie. 5UN was QSO 4IAK on 40. 5ANL works 4FR schedule on 176 meters and reports 5AHY, Shamrock, Okla., on with 201-A and "B" batts on 155 meters. 5CU is going to University but his Dad promises to have the old station going on 40 meters real soon. 5ADO moved his station and will be back with 150 watts. 5APQ has an "H" tube coming but in meantime worked "AIB" on 80 meters after sun up. 5AQW has a 202 on 76 meters and a Telefunken on 40 meters. 5ASK installing "H" tube and has schedule with 5AWE, 5ATV heard South Africa with an audibility of R6 on 1 step. 5PU says he can't get a 50 watt in one piece—Better sue 'em for mental anguish, OM. 5ABO is living up a flock of Hams in this vicinity. 5GJ hasn't had much time for traffic. 5AGK has his antenna arranged like a fire station—ready for a quick change—From 200 meters down to 80 and 40 meters in four minutes. Old shot-gun, 5TW, is installing an "H" tube. 5VM has evil designs on Hoover's cup. 5DW has reputation for treating 'em ruff—meaning transmitter tubes. Poor "H" tube, we wonder how long it will perk. Fellows, next month starts the new year. Let's show Fred Schnell we don't live way down in the sticks for nothing. Here's for more stations, more traffic, more reports, more DX, more fellowship and a better ARRL.

Traffic: 5APG 1, 5UF 9, 5ANL 11, 5ADO 2, 5APQ 11, 5AAV 12, 5ATV 14, 5ATK 14, 5ABO 18, 5SW 30, 5AQW 11, 5PU 5, 5GJ 23, 5AGK 3, 5ASP 5.

SOUTHERN TEXAS—This has been one of the most interesting months in amateur circles. A large number of reports have been received and each had a little more than the conventional QRV. Steps have been taken to cooperate with the Army. 5OX has not been on for several months but is taking the air with 500 watts of French bottles. 5EW has a fone and buzzer going with 100 watts on 180 meters in addition to his 40 meter rig with which he works all around the globe. 5ZAI has the following announcement from ch9TC: Will not be in radio any longer since he has no spare time. Advise QST and the gang. This report came thru ch2LD (Sorry ch9TC-ADM) Corpus Christi came back to life very much. He reports he is QRV for any J, Ber, A or Z traffic. That is saying a plenty in just a few words. 5APM is QSO Australia and South America on ten watts. San Antonio has been represented by 5HS, and 5HC. We have a newcomer, 5WW, at Jasper. He has a schedule with 5ACV and 5ASD.

Traffic: 5WW 9, 5HS 1, 5HC 12, 5MS 26, 5EW 18.

CANADA

SEVERAL things of note have occurred during the past month in the Dominion of Canada. The most notable from a League standpoint are the election of division managers in the Vanalta, Winnipeg and Maritime divisions and the new wavelength issued by the Department of Marine & Fisheries for the use of Canadian amateurs. The CGM noted with great pleasure the active campaign carried on in the Vanalta and Winnipeg divisions for the purpose of putting in a new DM. When we have an active campaign of this kind, it means that the men are taking a real interest in the work of the division and we have great pleasure in declaring Mr. A. H. Amusson, Canadian 4GT, elected the new Division Manager of the Vanalta division for the two years commencing January 1st, 1926. Mr. Frank E. Rutland, Canadian 4DE of Winnipeg was elected by a large majority the new division Manager for the Winnipeg Division, and the votes of the electors at the same time decided in favour of the change from the name Winnipeg division to "Prairie division," the former name being considered as too local in character and prejudicial to the interests of the sister province of Saskatchewan. Bill Borrett, as was expected, was returned unanimously for the Maritime division, nobody else being mentioned except him for the office.

Great interest has been aroused by the Department of Marine and Fisheries announcement of the new Trans-Canada wave to replace the 120 meter prayer

QST FOR FEBRUARY, 1926

meeting wave. This wave is 52.51 meters and may be used for Trans-Canada and inter-Empire work only, that is, it is not to be used for regular traffic handling except between Canadian stations or those within the British Empire. The Department wants us to be particularly careful to be absolutely accurate as to our wave so that we may never vary therefrom and interfere with commercial stations from whose wave band this particular wave has been carved out for our use. In return for the above concession by the Department, Canadian amateurs are to be deprived of the 120 meter wave until after April the 1st next, which is to be used for other services and also the wave of 198 meters which is to be used for an American telephone service.

In closing this report, the Canadian Manager would like to emphasize the desirability of all our Canadian stations using the new wave on Wednesday nights particularly for the prayer meeting. The time of this has been changed so as to make it earlier in the evening, the time being now nine P. M. Central Standard Time and already communication has been established by many stations from Toronto to the West Coast on this wavelength without difficulty. Let us all unite in repeating last winter's activities between Canadian stations.

MARITIME DIVISION W. C. Borrett, Manager

HONOURS this month go to Arthur Crowell of 1DQ, who has made a splendid comeback by working A-3LH with an input of about two hundred watts. Arthur always seems to come back into the game at the right moment, and it is a very true saying that one would have to get up very early these days to catch him napping. Another good scheme he has started by placing a box in the lobby of the Casino Theatre, where he turns the crank, where BCL and other patrons may deposit messages to go via ARRL.

1AR, as usual, is stirring up the ether with his Mullard 500 watter working to full capacity and has been QSO Australia several times this year. 1DD has logged fifteen Aussies and NZ stations this month but ND on QSO so far. 1DJ is still the lone Halifax station on the air and spends most of his time QSO with c9BJ, where ex-1EB sometimes pounds the key. 1AK, of St. John, is on every day from noon to five PM and finds it FB on 40 meters. He has also been ASO at night with the USA west coast and also with c5S. 1EI not to be outdone by 1AK, has also worked U 6's. 1AI of Millerton, is now getting back to the game and is all set for this month. 1AW and 1ED are working together and appear on Wednesday nights mostly. 1CO of Summerside reports that he is leaving for California but is trying to get another ham started in Summerside before he goes. 1AQ is a new low powered station of Fredericton. Please try and pick him up. 1AM and 1AN are juggling with a Hertz antenna. Results later. 8AR of St. Johns, Newfoundland, is going full blast and has worked dozens of USA and Canadian stations. He is on 40 meters. He should be FB for Europe traffic.

GREAT NEWS: A REAL LIVE HAM FOUND IN LABRADOR. The latest spot in which the Maritime Division has a ham station is Battle Harbor, Labrador. The call is BHL. Keep your ears open for him.

ALL STATIONS ARE ASKED TO GIVE GREATER COOPERATION THIS YEAR BY REPORTING PROMPTLY ON THE 15TH OF THE MONTH TO THE ADM OR DM. MAKE THIS RESOLUTION. DON'T FORGET TO USE OUR NEW WAVELENGTH 52.51 METERS ON WEDNESDAYS AT 11 PM AST.

Traffic: 1AK 17, 1EI 1, 1DD 11.

ONTARIO DIVISION W. Y. Sloan, Manager

ONTARIO now has divisional newspapers. 3FC FIRST WINNER RADIO MERIT TROPHY TORONTO CLUB PLANS MOSSBACK'S RE-UNION.

NORTHERN DIVISION—3NI is certainly stepping out in great shape, and is working excellent DX with 75 watts input on an old withered 203. His 40 meter DX includes bz1IA, and, while working z3AF, was reported R5 in the land of the "Zedders." Not much activity in this division outside of this station. 3HP is now off the air and 3AAZ is still experimenting.

QST FOR FEBRUARY, 1926

Good old 3GG reports that he is still banging away on the tone with some of the old timers on the ultra-upper wave bands! HI!

EASTERN DIVISION—3MT at Harlem, had to install a gas engine and generator to obtain a reliable power supply. 3AFZ has annexed a YL, turned her into an OW and soon hopes to have her pounding brass. Two new stations have made their debut in the Ottawa district. They are 3GJ and 3KT. Welcome, fellows, there's lots of room. 3AFP has changed his cage antenna for a single wire, as his pole showed symptoms of that dreaded mast disease known as "heebie-jeebies." The strain was evidently too much for its nerves—and for AFP's.

SOUTHERN DIVISION—3XI, as regular as clock-work, hands in another fine report. 3KP complains that the weather is like the Old Gray Mare. 3KA is giving a metal pipe antenna a trial. 3DH chirped across the pond with his faithful fiver, while 3ZB worked the coast on a pair of 201's. 3FU seems like a humdinger and 3ZB's 7½ watter is blushing merrily. Everything is Hotsy-Totsy now! 3AQ has built a beautiful little station and is going to be on the job right away, while 3MF is still the postman QRW with cards.

CENTRAL DIVISION—All the headlines about US this month! Lil' more hot news from you other fellows and you'll get onto the front page too. What do you think of our division magazine, "QTO," fellows? It's just what you've been asking for all along and you're going to get it regularly now. 3HT has a "fiver" with a reasonable input and says it is FB for 40. He is doing his best to keep Hamilton on the map. Galt seems the only other active burg in this division outside of Toronto, and 3AA is certainly doing his best to keep the good work up. This station deserves a medal for consistency. At the last meeting of the Wireless Assn. of Ontario, 3FC was made premier recipient of the Radio Merit Trophy in recognition of his fine DX. This is a monthly trophy and will certainly keep the locals pepped up. An oldtimers reunion will be the feature of the next meeting of this club. The pre-war mossbacks are expected to turn out in large numbers. Here's a funny situation for you—J. F. Hill, 4AJ, resident of Regina, student at U of Toronto, 2ND op at 9BJ, Toronto, is visiting in Hanover, Ontario and is operating there. "AJ" is CM of Toronto and Regina and it looks as if he were angling for the Hanover job. Traffic is not so bad in Toronto and the totals are certainly promis-



CAN. 3FU IS A WHOLESALE GROCER

ing. 3EL is doing splendid lowpower DX, but had the misfortune to blow a generator. SPECIAL UXTRY! By the time you are reading this, you will have ordered a new pair of diaphragms for your fones—extra thick, as 3VH is opening up again immediately. This station will NOT use a Hertz, but duck your heads, you Aussies, here comes VHT's signals.

Traffic: 9BJ 62, 9AL 16, 8AEL 28, 3XI 13, 3AZ 12, 3KQ 11, 3FU 11, 3KA 11, 3FC 10, 3CK 9, 3GJ 6, 3AFP 5, 3AF 4, 3DH 4, 3BR 4, 3KP 1, 3ZD 1, 3ZP 1.

QUEBEC DIVISION J. V. Argyle, Mgr.

AFTER our big convention interest pepped up everywhere, traffic increasing, DX improving and new stations operating all over the division. 2AL deserves special mention, being a graduated DCL who now spends all his time on the key on the 40 meter band. 2BE worked three Italians in one night and had G2NM phoning him. 2BG, out very late at nights, worked one Italian. 2CG worked Honolulu and a ship off the Canary Islands. 2AX continues good work. 2FO blew his sky ripper—

ears are in order. 2AZ returned to the fold. 2AN is active at times as is 2AU. 2BT again rebuilds. 2CB remains on the glorious western Ocean. 2DO is now on 40 meters and doing well. 2JC is heard on 75 meters working merrily. The use of the 52 meter wave is increasing. 2CG uses it most of the time. 2BC and 2AL are also active on this wave. Use this all the time, boys, and the world will listen there for you as they listen for G's on 45.

Traffic: 2BG 23, 2BG 18, 2CG 23, 2AU 17.

VANCOUVER DIVISION
Wm. J. Rowan, Mgr.

NOVEMBER has been the worst traffic handling month in the record of the division at this time of the year. According to all reports, it seems to be the effects of the skipped distances common on the 40 meter band. A number of the fellows are raving about going back to 175 meters and ham around with phone Hi. 5AS has been holding forth on 37.5 and only handled one msg. 5DD has had his call changed to 5AG. 5BM says he would rather work on 80 meters any day. 5HS ORS No. 13, got all settled in his new QRA and promptly shot his tubes. Hi. 5AN thinks the Heavyside layer has gone for a walk and is going to try 20 meters to find what happened to it. 5HB moved into his new garage and is starting to fix up the old heap in it. he says, "80 meters for ever". 5GO is not getting satisfactory results from his "Big Ben" yet DX in proportion to input is the bunk. 5GF has a new vertical cage working on 40 meters input about 100 watts. 5GU was tuning up his old heap lately preparatory to coming back. 5BH is now 5HF and brags a 50 watter now. There are some new hams in the making around Vancouver but no definite action on them yet. 5CT on the Island says the more he improves his set on 40 meters, the worse it gets. (That's Irish art.) 5BL was heard using a Zephefin type antenna described in QST some time

ago. It works FB but he had bad luck with his dynamotor. 5HK got his pole blown down. 4GT, in Calgary is still doing his stuff consistently. Has worked G-2S2 and South African A6N. 4CG is a newcomer on the air and has worked nearly all dists. on 6 1/2 watts input. 4AL is another low power artist. 4IO continues to hold the fort on 80 meters and has another report from NZ. 5GT, Prince Rupert, says he is completely in a hole as far as 40 meter sigs go after sunset and is seriously considering 80 meters again where skeds can be kept with consistency.

Traffic: 5GT 6, 4AL 3, 4GT 10, 4IO 4, 5AN 8, 5HS 1, 5BM 3, 5AS 1, 5GF 2.

WINNIPEG DIVISION
W. R. Pottle, Manager

THIS month has been a very active one and the gang are right on their toes determined to make this season a record breaker for the division. The Gang were very much pleased with the result of the election for the C. G. M. 4DE is doing some mighty fine work with his 250 watter. He blew one 250 but its O. K., he has three spares. Hi. 4DW popped a fiver but made up for it by making the first station worked on his new tube a "2." 4DF has a wicked punch behind his sigs. The combined station 4EA and 4FZ gets out good on A. C. but promises to have a civilized plate supply soon. 4AW's "S" tubes won't "oscillate" or whatever an "S" tube is supposed to do. 4AE is on 40 meters now. 4GX is opening up in Winnipeg. 4AS and 4AW are operating on GNR. 4DY is down on 40 meters and gets good DX. 4CR is on a trip through USA and Canada. 4CB is back on the air and doing good work on 40 meters. 4FC's aerial crashed again. 4FA is getting fine DX. 4BF has the "Bug" again and has bought a new pile of stuff. Hi. 4AO has at least got down to 40. 4HH is patiently waiting for his 250 watt lamp.

TRAFFIC SUMMARY BY STATES

ATLANTIC DIVISION				
State or Division	ADM	Orig.	Del.	Rel. Total
MD.	G. L. Deitmann, Jr.	9	9	7 42
Del.	No report	—	—	—
D. of C.	A. B. Goodall	—	—	215
So. N. J.	H. W. Densham	17	16	68 194
W. N. Y.	G. S. Taylor	1094	93	413 1528
W. Pa.	P. E. Wiggin	231	17	192 443
E. Pa.	J. E. Rau	52	39	350 351
		1404	174	1030 2681
CENTRAL DIVISION				
Ohio	C. E. Nichols	151	132	479 729
Ind.	D. J. Anrus	89	96	514 708
Mich.	C. E. Darr	—	—	— 595
Ill.	W. E. Schweitzer	479	388	300 918
Ky.	J. C. Anderson	20	4	41 65
Wis.	C. N. Grapo	—	—	— 2093
		759	620	1333 4916
DAKOTA DIVISION				
Minn.	C. L. Barker	125	138	252 1620
No. Dak.	M. L. Monsoe	7	1	8 16
So. Dak.	M. J. Junkins	47	51	146 243
		179	156	506 1879
DELTA DIVISION				
Ark.	Dr. L. M. Hunter	24	4	39 67
Tenn.	L. K. Rush	15	1	119 135
La.	C. O. Brietag	1	—	27 28
Miss.	J. M. Gutette	100	11	68 179
		140	16	253 409
HUDSON DIVISION				
N. E. City	F. H. Marion	176	103	492 771
E. N. Y.	H. H. Ammenheuser	251	131	566 900
N. N. J.	A. G. Weston, Jr.	51	39	403 490
		478	273	1481 2251
MIDWEST DIVISION				
Kans.	C. M. Lewis	32	7	207 256
Iowa	D. E. Watts	—	—	— 745
Mo.	L. B. Laizure	54	41	273 523
Nebr.	H. A. Neilson	106	52	270 571
		202	100	750 2105
NEW ENGLAND DIVISION				
Conn.	H. E. Nichols	31	54	160 305
Maine	A. P. Wheelton	34	38	174 306
W. Mass.	C. J. Greene	60	35	200 295
E. Mass.	Glady's Hannah	208	114	272 594
Vt.	Chas. T. Kerr	21	8	27 56
N. H.	C. P. Sawyer	22	13	132 167
R. I.	D. A. Fancher	31	19	91 131
		567	291	1056 1854

NORTHWESTERN DIVISION					
State or Division	ADM	Orig.	Del.	Rel. Total	
Wash.	Otto Johnson	84	57	248 297	
Ore.	Ashley C. Dixon, Jr.	25	33	214 307	
Idaho	K. S. Norquest	22	56	63 139	
Mont.	A. R. Wilson	12	13	18 34	
Alaska	Leo. H. Macdon	—	—	—	
		143	168	575 977	
PACIFIC DIVISION					
So. Sect.	M. E. McCreery	376	128	838 1660	
No. Sect.	P. W. Dann	28	15	251 623	
Nevada	C. B. Newcombe	—	—	—	
Hawaiian	K. A. Cantin	—	—	103 256	
		424	666	1154 2741	
ROANOKE DIVISION					
W. Va.	C. S. Hoffman	114	142	138 393	
Va.	J. E. Wohlford	10	3	54 70	
No. Car.	R. S. Morris	26	50	118 177	
		150	178	290 620	
ROCKY MOUNTAIN DIVISION					
Utah	Art Johnson	25	25	162 212	
Colo.	C. R. Steedman	75	77	339 658	
Wyo.	N. R. Hood	10	7	58 77	
		108	105	459 968	
SOUTHEASTERN DIVISION					
So. Car.	A. M. DuPre	—	—	— 164	
Ala.	H. S. Brownell	—	—	— 194	
Fla.	E. G. Watts Jr.	—	—	— 138	
Ga.	J. Morris	—	—	— 47	
Porto Rico	Luis Renach	—	—	— 119	
		—	—	— 662	
WEST GULF DIVISION					
No. Tex.	W. B. Forrest, Jr.	—	—	— 176	
So. Tex.	E. A. Salm	16	10	46 62	
Okla.	K. M. Ehret	14	18	90 168	
		30	28	136 406	
QUEBEC DIVISION					
Manager	J. V. Arvite	—	—	— 85	
VANCOUVER DIVISION					
Pr. Rupert	—	—	—	— 4	
Vanluta	Wm. J. Rowan, Mgr.	13	5	4 17	
Gr. Van.	—	5	5	2 15	
		18	5	6 28	
MARITIME DIVISION					
Manager	W. C. Roprett	9	8	12 29	
ONTARIO DIVISION					
Manager	W. V. Sloan	—	—	— 219	
TOTAL FOR THE COUNTRY					
Originated	4531	Delivered	2739	Relayed	9039
				Total	22640



A Magazine Devoted Exclusively to the Radio Amateur

INDEX TO VOLUME IX

January 1925 — December 1925

Published as a supplement to QST
for February, 1926, Vol. X, No. 2

INDEX TO VOLUME IX

January 1925—December 1925

AMATEUR RADIO STATIONS

British 2NB, Newark, England.....	59, June
2OD, Bucks, England.....	39, Aug.
2SZ, London, England.....	54, March
5LF, London, England.....	48, Jan.
Canadian 1EB, Halifax, N. S.....	55, March
3EN, Ottawa, Canada.....	52, Nov.
1AF-1XJ, Cambridge, Mass.....	45, July
1ARE, Pittsfield, Mass.....	52, Oct.
2WC, Brooklyn, N. Y.....	51, Dec.
3APV, Chevy Chase, Md.....	39, Sept.
3OT, Ambler, Penna.....	58, June
4BY, Savannah, Ga.....	46, April
4JE, San Juan, Porto Rico.....	59, June
4ZD-4XX, Savannah, Ga.....	38, Sept.
5ACL, Dallas, Tex.....	53, Nov.
5ZAI, Beeville, Tex.....	52, Dec.
6AWT, San Francisco, Calif.....	41, Jan.
6AWT, Hoover Cup Winner 1924.....	54, May.
6DD, Grass Valley, Calif.....	53, March
6LJ-6GFT-6XP, Los Angeles, Calif.....	40, Aug.
6OL, Stanford University, Calif.....	58, Nov.
6ZH, San Ysidro, Calif.....	43, July
7NT, Butte, Mont.....	54, Oct.
8ASE, Oak Park, Elm Grove, W. Va.....	41, Aug.
8BEI, Collins, Ohio.....	42, Feb.
8BNH, Akron, Ohio.....	54, Nov.
8BYN, Columbus, Ohio.....	44, July
8DGS, Cleveland, Ohio.....	41, Feb.
8XC-8GU, Erie, Penna.....	44, April
8ZE-8GX, Oberlin College, Ohio.....	39, Sept.
9AV, Union City, Indiana.....	45, April
9BMX, St. Paul, Minn.....	54, March
9CXX, Cedar Rapids, Iowa.....	53, Oct.
9UQ, Ames, Iowa.....	53, Dec.

AMATEUR REGULATIONS AND LEGISLATION

Argentina: Argentine Regulations (memo).....	36, May
Announcement regarding (I. A. R. U. News).....	50, Oct.
Belgium: Belgian Amateurs licensed (announcement).....	8, June
Brazil: Regulations in (memo).....	30, May
Canada: Canadian Wavelengths Assigned (announcement).....	61, June
China: Regulations in Macao, China (memo).....	36, May
Spain: Extracts from Spanish Radio Laws.....	49, Jan.
Sweden: Swedish Regulations.....	48, Feb.
United States: Amendment to Regulations.....	38, July
A New Amateur Band at $\frac{3}{4}$ Meter.....	36, May
At Last! Re Underwriters' Regulations (Pember).....	45, May
Fair Warning! Re interference.....	39, April
New Regulations For Transmitting Stations.....	29, March
Picture Transmission Permitted Under General Amateur License.....	38, July
Prospective Regulation.....	26, Jan.
Reinartz Circuit Approved.....	57, June
Correction—Reinartz Circuit Not Approved.....	19, July
Sending Licenses Suspended.....	37, May
The Hoover Bill (Editorial).....	7, Feb.
The Underwriters' Rules (MacKeechnie).....	70, July
150-200 (Editorial).....	7, Aug.

AMPLIFIERS—AUDIO AND RADIO

A Constant Current Amplifier (Meagher).....	48, May
Adding Punch to Your Neutrodyne (Budlong).....	18, Sept.
And Input Transformer (for superheterodynes).....	43, Oct.
A Power-Amplifier Transmitter for the Low Wave (Hoffman).....	30, Sept.
A True Cascade R. F. Amplifier (Hull).....	8, Oct.
A Tuned Audio Transformer (Braden).....	43, March

High Ratio and High Amplification (Kruse).....	27, Sept.
Improving the R. F. Amplifier (Burns).....	41, May
Measurement of the Voltage Ratio of Audio and Radio Transformers (Ramsey).....	24, Aug.
Notes on Reflexing Receivers (Budlong).....	30, March
Shooting Trouble in the Superhet (Clayton).....	15, July
The DeForest D-17 Receiver (Livingstone).....	16, Aug.
The Deresnadyne (Andrews & Beane).....	36, March
The Design of the Grebe Synchrophase (Batcher).....	13, April
The Isofarad Receiver (Minnium).....	24, May
The Neutrodyne C. W. Tuner at 9ZT.....	19, Jan.
The One-Stage R. F. Amplifier (Pendleton).....	21, Nov.
The Radiodyne Receiver (Lewis).....	21, June
The Regenaformer (Browning).....	21, April

ANTENNA SYSTEMS

A Neat Loop.....	38, July
Antenna Fundamentals (Benton).....	53, Feb.
A Simpler Way to Find the Fundamental (Kruse).....	32, Jan.
A Special Short-Wave Antenna (Pickard).....	52, June
At Last—An Approved Lead-in Bushing.....	20, June
Canadian 2CG's Capacity-Coupled Antenna (Argyle).....	57, May
Cheap Insulators.....	43, April
Counterpoise or Ground? (Exp. Section).....	35, Aug.
Direct Current Resistance of Antennas.....	39, Sept.
Even Harmonic Operation (McNary).....	59, Oct.
Glass Insulators (Bonsted).....	70, July
Harmonic Transmission (Thatcher).....	51, Sept.
Loops and Fords (Wright).....	33, July
Our Friend the Node.....	34, Jan.
Practical Lecher Wires (Woodruff).....	11, Sept.
Reinartz Circuit Not Approved.....	19, July
Some Thanks. Re Underground antennas (Rogers).....	62, May
Steadying Our Notes. Includes antenna suggestions (Kruse).....	38, June
The Hertz Antenna at 20 and 40 Meters (Williams).....	24, July
The Low Power Report. Includes data on loop transmission.....	44, June
The Receiving Antenna.....	33, Jan.
Top Loading Antennas and Loops (Murphy).....	49, May
Transmitting Hints.....	35, Sept.
Underground Antennas (Watson).....	62, May

BATTERIES

Biasing Batteries for Detection (Chase).....	53, Feb.
Loops and Fords. Dry cell plate supply (Wright).....	33, July
Emergency Power Supply (A.L.B.).....	47, May

BETTER OPERATING PRACTICES

A Challenge. Re use of "CQ" (Clark).....	Y, May
An Efficient Radio Relay Station (Hynes).....	I, June
An English Ham's Complaint (Partridge).....	55, April
Article by "F.E.H.".....	I, April
Bugs. Proper use of (Watson).....	65, Aug.
Calling Practice (Handy).....	II, Oct.
Calling Practice.....	48, Aug.
Check! Re use of spark and I.C.W. (Descamps).....	68, May
Cooperate for Better Operating.....	I, Oct.
Do You Tell The Truth (Editorial).....	7, Nov.
Fair Warning! Re interference.....	39, April
How to Use the Finish Signs AR-K-SK (Wallace).....	III, April
How Much Longer Must This Be True? (Matzinger).....	54, Feb.
Improving Our Traffic Handling (Watts).....	45, Aug.
Keeping A Log (Budlong).....	35, Nov.
Keying (Glaser).....	51, Sept.
Key Thump Filters (R.S.K.).....	31, Nov.
Let's Continue to Deserve This (Secretan).....	60, March
Numbering Messages.....	I, Dec.

Operating Your Station (McAuly)	48, July
Official Relay Station Operating Rules	47, Aug.
QRS Pse (Adamowski)	54, Jan.
Re: QSR's (Peacock)	53, April
"R" System of Audibility	63, May
Sending Licenses Suspended (includes diagrams of prohibited circuits)	37, May
Some Real Traffic Ideas (Kellam)	55, April
Something For Station Owners to Consider (F.E.H.)	11, May
Steadying Our Notes (Kruse)	38, June
The Five-Point System (Fenner)	1, June
Correction to (diagram)	53, July
This Is Good! Designating waveband in call (Jackson)	56, April
Vigilance Committees: A.R.R.L. Vigilance Committees (Schnell)	11, April
Local Vigilance Committees (Editorial)	7, May
Traffic Articles on: I, April; 52, July; IV, Sept. What Is an ORS—and Why? (Quinby)	1, March
Working Break-In (Thatcher)	72, July
Working DX (4FM)	1, Dec.
Use a Break-In	111, Dec.
Use the Service Message!	1, Sept.

BOOK REVIEWS

A Modern Super-Heterodyne Type Receiver (E. H. Lewis & staff)	38, Dec.
Henley's "Workable Radio Receivers" (Anderson & Lewis)	53, May
Guide to the Radio Art (Dr. P. Lertes)	37, Dec.
Illustrated Technical Dictionary, Vol. II (Alfred Schloman & C. Kingbrunner)	37, Dec.
Manual of Radiotelephony (Jorge A. Duclout)	37, Dec.
Measurements of Electrical Resistance and Mechanical Strength of Storage Battery Separators (C. L. Snyder)	38, Dec.
Radio Interference (Report of the N. E. L. A.)	38, Dec.
Radio Simplified (Kendall and Koehler—Revised by J. M. Clayton)	37, Dec.
Radio Theory and Operating (Mary Texanna Loomis)	38, Dec.
Robison's Manual of Radio Telegraphy and Telephony (U.S. Naval Institute Press)	38, Dec.
Standard Electrical Dictionary (T. O'Connor Sloane and Prof. A. E. Watson)	46, Feb.
The 5-Language Dictionary for Radioamateurs (W. DeHass)	37, Dec.

COILS

About Coils—Part I (Hatry)	48, Jan.
Part II	45, Feb.
Adjusting the Transmitter. Helix data (Clayton)	23, June
Celluloid-Supported Coils (Wallace)	21, Feb.
Computation Charts. Coil design by graphs (MacArthur)	42, June
Concerning Pancakes (Peters)	39, Feb.
Designing the Secondary Coil. Coil design by charts. (Burchill)	16, Sept.
Homemade Transmitter Parts. Coil forms (Hatry)	31, May
New Coils and Condensers	19, Dec.
New Coil Forms	40, Sept.
Plug-In-Coil Receivers (Clayton)	11, Aug.
Skeleton-Frame Helical Coils (Hazard)	54, June
Some Cylindrical Self-Supporting Coils (Clayton)	9, Jan.
The Sacred Angle. Neutrodyne coil adjustment (Budlong)	19, May
Toroids (Marco)	9, Dec.
Transmitting Hints. Description of "Meissner" coils	35, Sept.
Tubes for Coils (Akers)	42, Feb.
Tuners With Spaced Windings (Kruse)	10, Jan.
What Size Wire (Marco)	30, June

CONDENSERS

A Cheap Transmitting Condenser (Redington)	53, April
A Good Low-Capacity Variable Condenser	32, Sept.
A Novel Condenser	39, Oct.
Computation Charts. Capacity and Inductance charts (MacArthur)	42, June

Designing the Secondary Coil. Includes capacity charts. (Burchill)	16, Sept.
Good Mica Condensers	29, Sept.
Home-Made Transmitter Parts (Hatry)	31, May
New Coils and Condensers	19, Dec.
Suggestions for Transmitters. Series condenser information included	54, Feb.
The Grid Condenser	34, Jan.
The X-L "Vario-Denser"	12, July
Unique Variable Condensers	29, Jan.
Variable Transmitting Condensers	34, Nov.
Why Not Screened Condensers (Hatry)	45, Nov.

CONTESTS—TESTS—RELAYS—RECORDS

China to Chile!	49, Oct.
Cooper Cups for 5, 20 and 40 Meter Work: Announcement	17, Jan.
Don't Forget the Cups	42, July
Daylight Radio Communication Wins!	9, March
Eclipse Tests: A Nationwide Fading Test (announcement)	25, Jan.
The Eclipse and the Experimenter	34, Jan.
Experimenters Section Report	50, March
The Eclipse Tests (report on)	24, April
Eclipse at Long's Corners, Ontario (c3AF and c3AFP)	47, April
England and Australia Work in Daylight!	23, July
Governors-President Relay: Announcement of 8, Jan. Announcement	12, Feb.
Results of (Duvall)	39, May
Message Routings	1, May
Midsummer Traffic Tests: Announcement	47, June
Last Notice!	29, July
N. A. N. A. Thanksgiving Relay Report	XV, Feb.
Pacific Division Cops Two Trophies	44, March
Picture Transmission Prizes: Announcement (Jenkins)	18, March
Book Prizes Also	41, July
Jenkins Awards	21, Oct.
Pioneer Short Wave Work (Jones)	8, May
Round the World Relay (I. A. R. U. News)	42, Sept.
Super DX (Foreign contact)	18, Jan.
Short Wave Daylight Transcon Report (F. H. S.)	38, Jan.
6AWT, Hoover Cup Winner 1924	54, May
6TS and 2MU First Across on 40 Meters	35, March
The Army Links Up With the Amateur (details of plan)	22, Oct.
The Army-ARRL Affiliation (Editorial)	7, Dec.
The Jewell 1926 Low-Power Contest	28, Oct.
The Month's International DX	13, Feb.
The Shenandoah Flight (Navy Dept. commendation)	52, Jan.
Traffic Trophy: A Trophy for the King of the Traffic Handlers!	XV, Feb.
Terms of	11, Sept.
The Traffic Trophy (monthly report)	111, Oct.; 111, Nov.; 114, Dec.
Twenty-Meter Tests Put Daylight Signals Across America	31, Feb.
Twenty-Meter Tests From 1XAM (Exp. Section)	42, April
Washington Birthday Daylight Transcons: Announcement	17, Feb.
Results of	111, May
Who Was First Across on 20 Meters?	30, July

CONVENTIONS

Canadian ARRL Convention at Montreal, Quebec (report)	48, Nov.
Central Division Ohio State Convention (announcement)	23, July
Report on	48, Nov.
Dakota Division Convention (report)	23, Feb.
Dakota Divn. Minnesota State Convention	37, Nov.
Florida Convention (report)	49, March
Hoosier State Convention (report)	17, Sept.
Hudson Division 2nd Dist. Convention (announcement)	8, March
Report on	29, May
Maritime Division Convention (report)	29, May
Michigan State ARRL Convention (report)	31, April
Midwest Division-Iowa State Convention (report)	28, July

New England Division Convention (announcement)	34, March
Report on	49, June
N. E. Division Vermont Convention (announcement)	19, Aug.
Report on	44, Nov.
New Rules for ARRL Convention	32 April
Pacific Division ARRL Convention, First (report)	27, Jan.
Pacific Division ARRL Convention, Second (announcement)	11, Oct.
Report on	8, Dec.
Re Conventions	54, Feb.
Second Annual Western N. Y. Convention of the Atlantic Division (report)	25, Aug.
Third District Convention (postponement announcement)	31, April
Third National Convention: Announcements—35, March; 40, May; 27, June; 8, July; 9 August.	
Report on	29, Oct.
Tri-State Convention—Pittsburgh, Pa. (report)	28, March
Vancouver Division Convention (announcement)	19, Aug.
Report on	30, Nov.

COUNTERPOISE AND GROUND SYSTEMS

Counterpoise or Ground?	35, Aug.
Counterpoise vs Ground Reception (Sackman)	63, Dec.
Counterpoise Wire (5XAY)	36, Sept.
It Can't Be Done! Re working set without ground connection	32, Sept.

EDITORIALS

Avoiding Trouble (Warner)	7, March
Boost Your Club (Warner)	7, July
Do You Tell the Truth? (Warner)	7, Nov.
Election Time (Warner)	7, Sept.
Fish About a Bit (Warner)	7, Sept.
150-200 (Warner)	7, Aug.
Local Vigilance Committees (Warner)	7, May
Make A Brass Pounder (Warner)	7, Nov.
Onward! (Warner)	7, Oct.
Rank Yank Rudeness (Warner)	7, June
Shall We Change? Re new name for League (Warner)	7, June
The Army—ARRL Affiliation (Warner)	7, Dec.
The Hoover Bill (Warner)	7, Feb.
The IARU Congress (Warner)	7, May
The International Era (Warner)	7, July
The Why of It (Warner)	7, Dec.
This Interference Business (Warner)	7, April
This League of Ours (Warner)	7, Jan.
We Ask—re advertisers (Adams)	7, Sept.

EMERGENCY AND RELIEF WORK

Amateur Radio at Floyd Collins' Cave	42, May
Emergency Power Supply	47, May
QRR—Re: Railroad Emergency	8, March

EXPEDITIONS

KFUH: Have You Heard KFUH?	20, Feb.
"Stray" on	29, April
KFUH—Description of station (Heintz)	15, Nov.
KFUH's Receiver (Townsend)	19, Nov.
Miscellaneous: Re: The Shenandoah Flight	52, Jan.
Navy-MacMillan-Reinartz: The Navy-MacMillan Expedition Announcement (Mathews)	33, June
Short Wave Communication with WNP	20, July
The Radio Equipment of the Navy-MacMillan Arctic Expedition	21, July
MacMillan Shoves Off	15, Aug.
Contact With the MacMillan Expedition	1, Sept.
WNP	II, Oct.
WNP (logs)	III, Nov.
Navy-Schnell: Navy Picks Schnell for Tests	17, April
Schnell Sails on NRRL	46, May
Monthly Reports on Trip: 23, June; 31, July (with log); 28, August (with log); 27, Sept.; IV, October (with log).	
Short Notice Regarding NRRL	41, Oct.
Schnell Returns (K.B.W.)	25, Nov.
NRRL (logs)	II, Nov.

WJS: "Stray" on	63, May
The Mysterious WJS—details of set	20, Aug.
Chalk Up Another Credit For the Amateur	22, Aug.
VDM: Announcement re	61, June
The C.G.S. "Arctic" Sails Again	65, July
Reports on	60, Aug.; XV, Sept.

FICTION

Inchulation	66, June
The "CQ" Fiend (Carter)	40, July
The Great Discovery (Harte)	24, Feb.
T. O. M. Heard From Again (Sturley)	42, Oct.
The Supersink Receiver (Taurenwerfer)	23, Jan.

FILTERS

Amateur Filter Problems (Dellenbaugh)	24, Dec.
An "S" Tube and a Good Filter (Borton)	64, Aug.
D. C. Filters (Smith)	52, Sept.
Filters and the Motor Generator (Cramer)	64, Dec.
Key-Thump Filters	31, Nov.
Mercury Arc Rectifiers. Includes filter information (Smith)	21, Jan.
Rectifiers and Filters	29, Feb.
Ringing Machine Radio Interference (Fritz)	56, June
Smoothing Circuits for Half-Wave Rectification (Dellenbaugh)	33, Aug.
To Get a Good Note With Self-Rectification (Lowe)	61, March
Transformers and Reactors in Radio Sets (Chadwick) Part I	21, Sept.
Part II	37, Oct.
Transmitting Hints	35, Sept.

INTERFERENCE

An Interference Trap (Baldwin Noise Filter)	23, May
A. R. L. Vigilance Committees (Schnell) II, April	
Circumventing the Locals (Schermerhorn)	48, March
Curing Seattle's Radio Interference (Smeiser)	14, Nov.
Interference From Electric Heating Pads	24, Sept.
Local Vigilance Committees (Editorial)	7, May
Locating "Power Leaks" by Radio	13, Sept.
More QRN Storms (White)	72, July
One Cure for QRN to BCL's (Goodberlet)	66, June
QRN Storms (Biele)	63, May
QRN Elimination (Woodruff)	65, Aug.
Ringing Machine Radio Interference	56, June
Showing Up Missouri Troubles (Brownlee)	30, Feb.
The Interference Muddle (Williams)	30, Aug.

I. A. R. U.—CONGRESS

All Aboard for Paris (K.B.W.)	26, March
Appointment of Borrett as Canadian Representative	XV, May
Memo on	XV, June
Canadian Representation at the I. A. R. U. Conference	55, March
Constitution of the I. A. R. U.	14, June
International Amateur Radio Union Formed! (Warner)	9, June
The Congress and the Union	42, Aug.
The I. A. R. U. Congress (Editorial)	7, May

I. A. R. U. NEWS

England and Australia Work in Daylight	23, July
Hi-Power Commercial Short Wave Stations (List)	43, Aug.
Correction	44, Sept.
I. A. R. U. Election Notices: (Germany, Spain and Netherlands)	42, Aug.
(Brazil and Switzerland)	50, Oct.
Spain	54, Dec.
International Intermediates: Expanded List (C.A.S.)	22, Feb.
Lists of New Intermediates 8, July; 14, Aug.; 28, Oct.; 25, Nov.	
I. A. R. U. News (Monthly Department):	
48, Jan.	
47, Feb.	
46, July	
43, Aug.	
42, Sept.	
49, Oct.	
49, Nov.	
54, Dec.	
Super DX (K. B. W.)	13, Jan.
The International Era (Editorial)	7, July
The Month's International DX (K. B. W.)	13, Feb.

LOOPS

A Neat Loop	38, July
C. W. On a Loop	38, Feb.
Locating "Power Leaks" by Radio	18, Sept.
Loops and Fords (Wright)	33, July
The Low-Power Report (includes loop transmitter)	44, June
Top-Loading Antennas and Loops (Murphy)	49, May

MASTS

Masts for Cramped Spaces (May)	36, Sept.
The Mast at 9KC	23, Dec.

METERS

Grid Meters—use of	35, Sept.
Shunted Thermocouple Meters (Miller)	62, Dec.
Small Panel-Mounting Meters (J. M. C.)	36, Dec.

MISCELLANEOUS

A New Porcelain Socket	30, Dec.
A New Vernier Dial	30, Dec.
Army-Amateur Cooperation: The Army Links Up With the Amateur (includes copy of plan)	22, Oct.
Army-A.R.R.L. Affiliation (Editorial)	7, Dec.
A Simple Audio Oscillator (Halstead)	25, Sept.
A 360° Vernier Dial	15, Sept.
A Soldering Trick (L. W. H.)	37, April
Board of Directors A.R.R.L.: The November Elections	26, Jan.
The Annual Meeting of the A.R.R.L. Board	83, April
Election Notices	25, Sept.; 31, Oct.
Do You Want Call Book Supplements? (K. B. W.)	39, April
"Stray" on	37, Nov.
Experimenters' Section	34, Jan.
Also: 31, Feb.	
59, March	
42, April	
43, May	
37, July	

35, Aug.	
33, Sept.	
21, Oct.	
47, Nov.	
27, Dec.	
Frequency Doubling in Vacuum Tubes (Greenwood)	29, Dec.
Glass Panels (Twitchell)	26, July
High-Frequency Resistance Standards (Clayton)	25, Oct.
Isolantite (Caulfield)	65, Aug.
Loss Comparisons (Seibert)	37, Aug.
Measuring Very Small R. F. Currents (Turnbull)	31, Jan.
Navy Day Honor Roll	V, Dec.
Official Broadcast Stations:	51, July
Also: II, Sept.	
II, Oct.	

II, Nov

IV, Dec.

Patents (Brady)	64, Aug.
Photographs for QST. Advice on taking (F. C. B.)	41, April
Postage Rates on Cards (Bell)	71, July
Proper Graduations For Dials (Briggs)	39, Dec.
QST de Advertising Manager	8, Jan.
Quarterly Statement of Revenue and Expenses, A. R. L.:	
34, April	
8, July	

31, Oct.

17, Dec.

R. F. Properties of Insulating Materials (Preston and Hall)	26, Feb.
Rag Chewers' Club: Entrance requirements	29, June
Also:	45, July; 38, Aug.
Rating Circuit Resistance (Browning)	42, Dec.
Report on the June (Traffic Dept.) Questionnaire (Handy)	II, Dec.
6AWT Hits Again (QSO Japan)	38, April
The Amateur's Test Table (Hatry)	35, April
The Bowdoin's Generators (Berry)	26, Aug.
The Fynur Slow Motion Control	34, Nov.

Page numbers in Roman Numerals refer to Traffic Department in issue indicated.

The Motional Impedances of an Electro-Dynamic Loud Speaker (Kennelly)	35, June
Tools Galore!	44, Oct.
U. S. Naval Reserve Force: Another Chance to Put One Over (Maxim)	20, Feb.
Radiomen Being Enrolled in the U.S.N.R.F. (K. B. W.)	30, April
The Naval Reserve (Willis)	65, June
Wavelength Measurement (White)	60, Oct.
What is the Radio Club of Argentina (Repetto)	33, Dec.
Why the Inspection Service is Short of Funds	46, May

OBITUARY

Banzhaf, Tom	19, Feb.
Bishop, Leon W.	8, Jan.
Breitenbach, Frank	19, Feb.
Caswell, Carlton Taft	3, June
Cole, Bruce	8, June
Heavside, Oliver	18, April
King, Margaret M.	8, March
Lambert, P. Graham	3, June
Phillips, George M.	8, Jan.
Schanck, Harrison	8, Jan.

PICTURE TRANSMISSION

Picture Transmission Permitted Under General Amateur License	38, July
Practical Picture Transmission (Dewhurst)	12, Dec.
Re: Jenkins Machine (Jenkins Laboratories)	69, Nov.
Television (Exp. Section)	37, July
Television Arrives (Bidwell)	9, July
The Jenkins Experimenters (Exp. Section)	36, Aug.
Visible Radio Communication (Wilkinson)	15, May

RECEIVERS—GENERAL

A "B" Battery Fuse	41, June
About Coils (Hatry) Part I	43, Jan.
Part II	43, Feb.
A Few Kinks on Reception (Blalack)	37, Feb.
A Neat Tuner Unit	47, March
A New Process Grid Leak	49, Sept.
An Interference Trap	23, May
A Novel Short-Wave Tuner	17, Feb.
A Simple 200-600 Meter Receiver	46, Oct.
A Three-Tube Neutrodyne for Short Waves (Ablowich)	41, Dec.
A True Cascade R. F. Amplifier (Hull)	3, Oct.
Biassing Batteries for Detection (Chase)	53, Feb.
Celluloid Supported Coils (Wallace)	21, Feb.
Circumventing the Locals (Schermerhorn)	48, March
Computation Charts. Coil design by charts (MacArthur)	42, June
Correction	25, July
Daylight Radio Communication Wins!	9, March
Designing the Secondary Coil. Charts for (Burchill)	16, Sept.
Giving the Coil and Condenser a Rest. (Kruse)	17, June
Glass Panels (Twitchell)	26, July
How to Eliminate Body Capacity Effects (Buffington)	50, Dec.
Improving the R. F. Amplifier (Burns)	41, May
Learning the Code by Listening (long wave receiver construction)	45, March
Regarding That Long-Wave Receiver (picture diagram)	32, June
Loops and Fords (Wright)	33, July
Losses in Sockets (Buehl)	55, Feb.
New Coils and Condensers	19, Dec.
New Coils Forms	40, Sept.
Notes on Reflexing Receivers (Budlong)	30, March
On Connecting Phones the Right Way (Silent)	54, April
Opening Out the Tuning Scale (Sonn)	48, Dec.
Pioneer Short-Wave Work (Jones)	8, May
Plug-In Coil Receivers (Clayton)	11, Aug.
Proper Graduations for Dials (Briggs)	39, Dec.
Rating Circuit Resistance (Browning)	42, Dec.
Receiver Dead Spots (Watts)	63, Dec.
Receiver Design (Rogers)	61, Oct.

Receiver and Wavemeter Calibration (Baker)	18, Dec.
Re: Marconi V-24	54, April
Reviewing the Receiver (Adams)	8, Sept.
Correction	28, Dec.
Short-Wave Receivers (Batcher)	33, Oct.
6CNC—a beautiful 5-Meter Station	51, March
Skeleton-Frame Helical Coils (Hazard)	54, June
The DeForest D-17 Receiver	16, Aug.
The Deresnadyne (Andrews and Beane)	36, March
The Design of the Grebe Syncrophase (Batcher)	18, April
The Five-Meter Tuner at 9APW	28, Jan.
The Isofarad Receiver (Minnium)	24, May
The Lopez Tuner	16, June
The Making of a Radio Receiver (Graham)	33, Nov.
The McCaa Anti-Static Devices (McCaa) Part 1	8, Feb.
Part II	18, March
Two letters on	66, June
The Mysterious WJS	20, Aug.
The New Carborundum Detector (Hartmann & Meagher)	31, Dec.
The One-Stage R. F. Amplifier (Pendleton)	21, Nov.
The Radiodyne Receiver (Lewis)	21, June
The Receiving Experimenter	33, Jan.
The Regenator (Browning)	23, April
The So-Called 3 Circuit Tuner	40, Feb.
The Uncle Sam Tuner	52, March
The Wavy Mast and the Airbrake Receiver (Everest)	22, May
Toroids (Marco)	9, Dec.
Tuners With Spaced Windings (Kruse)	10, Jan.
Underground Antennas (Watson)	62, May
Variometer Tuning for C. W. Reception (Schlorf)	46, Dec.
What Size Wire (Marco)	30, June

RECEIVERS—NEUTRODYNE

Adding Punch to Your Neutrodyne (Budlong)	18, Sept.
A Three-Tube Neutrodyne for Short Waves (Ablowich)	41, Dec.
Improving the R. F. Amplifier (Burns)	41, May
The Design of the Grebe Syncrophase (Batcher)	13, April
The Isofarad Receiver (Minnium)	24, May
The Neutrodyne C. W. Tuner at 9ZT	19, Jan.
The Regenator (Browning)	21, April
The Sacred Angle, Mounting Neutrodyne Coils (Budlong)	19, May
The X-L Variodensar	42, July

RECEIVERS—SUPERHETERODYNE

Shooting Trouble in the Superhet (Clayton)	15, July
The Radiola Superheterodyne. Note on (Kruse)	30, Jan.

RECTIFIERS

Aluminum Analysis Data (Benham)	53, April
Aluminum Rectifiers (Major)	51, Sept.
A New Tungar Charger	47, Oct.
Frozen Rectifiers (Lambert)	54, April
Kenotron Rectification (Lowe)	53, Jan.
Making A Synchronous Converter (Karing)	20, Sept.
Mercury Arc Rectifiers (Smith)	21, Jan.
Rectifiers and Filters	29, Feb.
Smoothing Circuits for Half-Wave Rectification (Delenbaugh)	33, Aug.
The Raytheon Rectifier (Pennybacker)	38, Nov.
To Get a Good Note With Self-Rectification (Lowe)	61, March

STANDARD FREQUENCY TRANSMISSION

Official Wavelength Stations:	34, Feb.
Also: 17, March	34, June
8, April	8, Aug.
21, May	46, Nov.

The Pacific Coast Standard Frequency Station (Henne)	27, Nov.
WWV and 6XBM Transmissions:	
12, Jan.	34, June
34, March	8, Aug.
21, May	30, Nov.

TRANSMITTING—GENERAL

A Cheap Transmitting Condenser (Redington)	53, April
Antenna Fundamentals (Benton)	53, Feb.
Arcless Keying (Keen)	71, July
A Simpler Way to Find the Fundamental (Kruse)	32, Jan.
Correction: Reinartz Circuit Not Approved	19, July
Crystal Oscillators: Concerning Crystal Oscillators (Exp. Sec.)	35, Jan.
Crystal Control (Taylor)	62, Dec.
Crystal Control for Amateur Transmitters (Clayton)	8, Nov.
Navy Developments in Crystal-Controlled Transmitters	41, Nov.
Oscillating Crystals (Exp. Section)	35, Aug.
Correction	41, Oct.
DX Rating. Re input (Taylor)	59, Nov.
Emergency Power Supply (A. L. B.)	47, May
England and Australia Work in Daylight!	23, July
Even Harmonic Operation (McNary)	59, Oct.
Experimenters Section	35, Aug.
Harmonic Transmission (Thatcher)	51, Sept.
Kenotron Rectification	53, Jan.
KFUH (Heintz)	15, Nov.
Mercury Arc Rectifiers (Smith)	21, Jan.
Notes on	23, Jan.
Misplaced Power (Romberg)	19, Sept.
More Harmonic Operation (Barrett)	63, Dec.
New Regulations for Transmitting Stations	29, March
New Transmitting Inductances	48, Nov.
Pioneer Short Wave Work (Jones)	8, May
Short Wave Low Power Arc Transmitters (Cohen)	46, June
Shunted Thermocouple Meters (Miller)	62, Dec.
6TS and 2MU First Across on 40 Meters	35, March
Some Radiophone Experiments (Roberts)	35, Feb.
Speaking of Low Power Work (Clayton)	14, Dec.
Steadying Our Notes (Kruse)	38, June
Suggestions for Transmitters (Imel)	54, Feb.
The Amateur Arc	39, Jan.
The Hertz Antenna at 20 and 40 Meters (Williams)	24, July
The Low Power Report (L. W. H.)	45, June
Top Loading Antennas and Loops (Murphy)	49, May
Variable Transmitting Condensers	34, Nov.

TRANSMITTERS—CIRCUITS AND CONSTRUCTION

Adjusting the Transmitter (Clayton)	23, Jan.
An Inexpensive Low Power Transmitter from Receiving Parts (Turner)	35, Dec.
A Power Amplifier Transmitter for the Low Waves (Hoffman)	30, Sept.
A Primary Filament Rheostat (McAuly)	40, Jan.
Arcless Keying (Keen)	71, July
A Reliable 3-5 Meter Sending Set (Hoffman)	19, April
2CG'S Capacity-Coupled Antenna (Argyle)	57, May
Celluloid Supported Coils (Wallace)	21, Feb.
Chalk Up Another Credit for the Amateur (Lopez and Baldwin)	22, Aug.
Crystal Control for Amateur Transmitters (Clayton)	8, Nov.
Daylight Radio Communication Wins! 20-meter sets	9, March
Experimenters Section. 20-meter circuits	31, Feb.
Experimenters Section. GCNC, a 5-meter set	51, March
Glass Insulators (Bonsted)	70, July
Glass Panels (Twitchell)	26, July
Home-Made Transmitter Parts (Hatry)	31, May
Interesting Short Wave Transmitter (Oxner)	54, Jan.
Keeping the Filament in One Piece (Woodruff)	28, Feb.
Key Thump Filters	31, Nov.
KFUH (Heintz)	15, Nov.

Loops and Fords (Wright)	33, July
Low Power Station 2BBX (Synnott)	20, Dec.
Making Your Own Bug (Kepler)	47, Jan.
Pioneer Short Wave Work (Jones)	8, May
Practical Lecher Wires (Woodruff)	11, Sept.
Regarding Primary Rheostats (Martin)	42, Jan.
Sending Licenses Suspended. Diagrams of prohibited circuits	37, May
Some Cylindrical Self-Supporting Coils (Clayton)	9, Jan.
Some Radiophone Experiments (Roberts)	35, Feb.
Suggestions for Transmitters (Imel)	54, Feb.
The 5-Meter Set at 9ZT	45, May
The Mysterious WJS	20, Aug.
The Pacific Coast Standard Frequency Station (Hennel)	27, Nov.
To Get a Good Note With Self Rectification (Lowe)	61, March
Transmitting Hints	35, Sept.

TRANSMITTERS—LOW POWER

An Inexpensive Low Power Transmitter from Receiving Parts (Turner)	35, Dec.
Loops and Fords (Wright)	33, July
Low Power Station 2BBX (Synnott)	20, Dec.
Pioneer Short-Wave Work. Includes data on five-watt portable transmitter for 3-20 meters (Jones)	8, May
Some Radiophone Experiments (Roberts)	35, Feb.
Speaking of Low Power Work (Clayton)	44, Dec.
The Low Power Report	44, June

TUBES

New RCA Tubes	40, Oct.
Standard Base Tubes (Curtis)	66, June

The New Magnavox Tube (Metcalf)	24, March
The Raytheon Rectifier (Pennybacker)	38, Nov.

WAVEMETERS

A Good Wavemeter (Clayton and Hatry)	40, March
A Handy Wavemeter Trick	28, March
A New Wavemeter	48, Oct.
Checking Up Wavemeter Methods (Lidbury)	50, June
Coil Harmonics—Important (Exp. Section)	42, April
Extending Wavemeter Ranges (Lampkin)	59, Oct.
More Wavemeter Calibration (Rose)	64, Aug.
Receiver and Wavemeter Calibration (Baker)	18, Dec.
That Wave Meter (Reinartz)	18, Feb.
Wavemeter Calibration (Teunisson)	65, June
Wavemeter Calibration (Exp. Section)	36, Aug.

WAVE PROPAGATION THEORIES

How Are Short Waves Reflected? (Joyce)	29, July
Is There a Heaviside Layer? (Pickard)	33, Sept.
The Reflection of Short Waves (Reinartz)	9, April
Wave Propagation at High Frequencies (Taylor and Hulbert)	12, Oct.

WHO'S WHO

Additions to the Headquarters Staff:	
A. L. Budlong; J. M. Clayton, F. E. Handy; L. W. Hatry; W. C. Murray	60, June
Pinney, George H., 1CKP	46, April
Three New Canadian Division Managers:	
W. R. Pottle; Wm. Rowan; W. M. Sutton	41, Sept.
Westervelt, F. B., 8VE-8ZAH	46, April
White, Elliott, "EW" of 1YB	46, April